

OPERATOR'S MANUAL

DECONTAMINATING
APPARATUS:
POWER-DRIVEN,
SKID-MOUNTED,
500-GALLON, M12A1
(NSN 4230-00-926-9488)

EQUIPMENT DESCRIPTION	1-2
OPERATING INSTRUCTIONS	2-1
PREVENTIVE MAINTENANCE CHECKS AND SERVICES (PMCS)	2-16
OPERATION UNDER USUAL CONDITIONS	2-57
OPERATION UNDER UNUSUAL CONDITIONS	2-134
TROUBLESHOOTING PROCEDURES	3-3
MAINTENANCE PROCEDURES	3-14

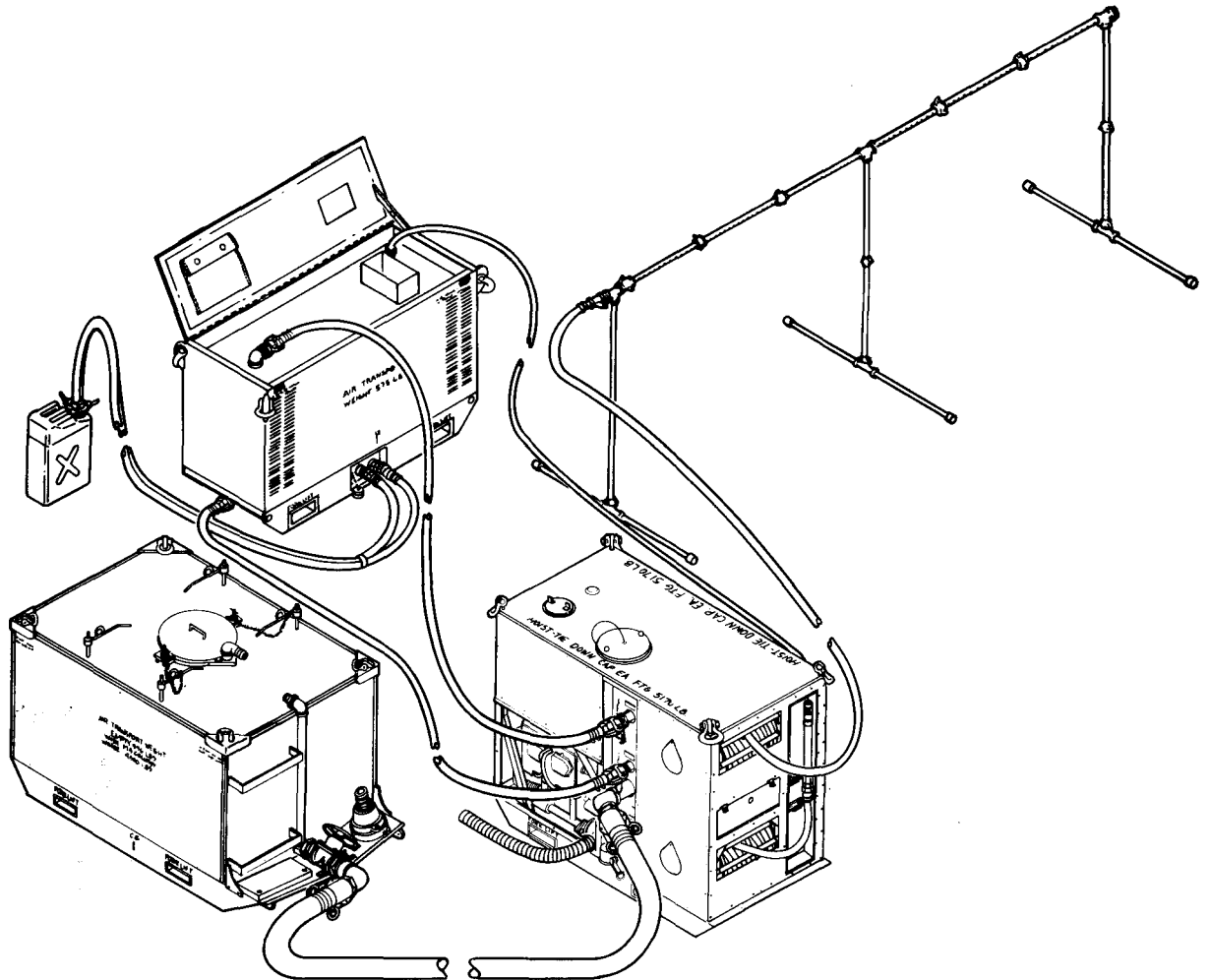

HEADQUARTERS, DEPARTMENT OF THE ARMY
JUNE 1986

CHANGE

HEADQUARTERS
DEPARTMENT OF THE ARMY
Washington D.C., 22 April 1997

NO. 2

**OPERATOR'S MANUAL
DECONTAMINATING APPARATUS, POWER-DRIVEN,
SKID-MOUNTED, MULTIPURPOSE, NONINTEGRAL
500-GALLON, M12A1
NSN 4230-00-926-9488
(EIC: 5FB)**

TM 3-4230-209-10, 20 June 1986 is changed as follows:

1. Remove old pages and insert new pages as indicated below:

Remove Pages

i and ii
1-1 and 1-2
1-9/(1-10 blank)
2-15 thru 2-56
2-59 and 2-60
2-65 thru 2-68
2-89 and 2-90
2-97 thru 2-102
None
2-127 and 2-128
2-135 thru 2-139/(2-140 blank)
3-1 and 3-2
3-5 and 3-6
3-17 and 3-18
A-1 and A-2
B-1 thru B-4
D-1 and D-2
Index 1 and Index 2
None
Cover Page

Insert Pages

i and ii
1-1 and 1-2
1-9/(1-10 blank)
2-15 thru 2-56
2-59 and 2-60
2-65 thru 2-68
2-89 and 2-90
2-97 thru 2-102
2-124.1 and 2-124.2
2-127 and 2-128
2-135 thru 2-139/(2-140 blank)
3-1 and 3-2
3-5 and 3-6
3-17 and 3-18
A-1 and A-2
B-1 thru B-4
D-1 and D-2
Index 1 and Index 2
2028-2(front/back side)
Cover Page

2. New or changed material is indicated by a vertical bar in the margin of the page and a hand pointing to changed graphic.

3. File this change sheet in front of the publication for reference purposes.

By Order of the Secretary of the Army:

DENNIS J. REIMER
General, United States Army
Chief of Staff

Official: 

JOEL B. HUDSON
Administrative Assistant to the
Secretary of the Army
03307

DISTRIBUTION To be distributed in accordance with the initial distribution number (IDN) 280168, requirements for TM 3-4230-209-10.

CHANGE
NO. 1

HEADQUARTERS
DEPARTMENT OF THE ARMY
WASHINGTON, D. C., 5 December 1986

Operator's and Organizational Maintenance Manual
DECONTAMINATING APPARATUS, POWER-DRIVEN, SKID-MOUNTED,
MULTI PURPOSE, NONINTEGRAL, 500-GALLON, M12A1
NSN 4230-00-926-9488

TM 3-4230-209-10, 20 June 1986 is changed as follows:

1. Remove old pages and insert new pages as indicated below:

Remove Pages

2-23 and 2-24
2-25 and 2-26
3-1 and 3-2

Insert Pages

2-23 and 2-24
2-25 and 2-26
3-1 and 3-2

2. New or changed material is indicated by a vertical bar in the margin of the page.
3. File this change sheet in front of the publication for reference purposes.

By Order of the Secretary of the Army:

JOHN A. WICKHAM, JR.
General, United States Army
Chief of Staff

Official:

R. L. DILWORTH
Brigadier General, United States Army
The Adjutant General

Distribution:

To be distributed in accordance with DA Form 12-28, Operator Maintenance requirements for Decontaminating Apparatus, Skid/Vehicle Mounted.

WARNING

**DEATH
OR SEVERE INJURY MAY RESULT IF
PERSONNEL FAIL TO OBSERVE WARNINGS**

DANGEROUS CHEMICALS, GASOLINE, HIGH VOLTAGE (maximum 24 volts), AND SCALDING WATER are used in the operation of the equipment. CARBON-MONOXIDE is present in the exhaust gases of the gasoline engine and the water heater.

Wear protective clothing and a mask when engaged in decontaminating operations. STB decontaminating agent and slurry are harmful to the skin, eyes, lungs, and clothing. If STB decontaminating agent or slurry gets into the eyes, flush them immediately with clear water. If STB decontaminating agent or slurry is taken internally, drink raw egg white, milk, rice gruel, or milk of magnesia. Do not induce vomiting and seek medical assistance immediately. If STB decontaminating agent or slurry contacts the skin, wash off immediately with clear water.

When engaged in decontaminating operations, protective clothing and mask must be worn. When mixing, blending, or spraying sodium hydroxide solution, personnel must wear full rubber protective clothing, gloves, boots, and mask. Avoid contact with the skin and eyes. Avoid breathing the dust.

An operator must be in attendance at all times during operation of the water heater. Water must be circulating through the water heater before fuel is ignited, as well as throughout the time the water heater is operating.

Insure that the main power cable is disconnected from the power source prior to performing inspection and servicing of electrical motors, control box, and rotating parts of the water heater.

Make certain that the fuel supply and fuel return lines are properly connected before operating the water heater.

Authorized fuel will be obtained only from authorized fuel services or fuel trucks. Siphoning fuel from vehicles is prohibited. Siphoning can cause static electricity, mouth and throat damage, and lead poisoning.

When operating drain valve, be careful to prevent injury to fingers.

Use caution when opening drums of Super Tropical Bleach (STB); wear protective clothing and mask. Avoid contact with skin or eyes. Avoid contamination with acids and oxidizable materials such as fuels, oils, paint products, disinfectants, and ammonia. Such contamination can cause release of hazardous gases. Keep container closed and stored in a cool dry place. Mix only in accordance with directions for use. In case of contact with skin or eyes, immediately flush continuously with water; for eyes get medical attention.

Keep clear of the exhaust stack during operation of the water heater.

The battery and battery compartment may be coated with acid caused by spillage or fumes. Wear protective clothing while working in this area. Wash your hands with baking soda and water solution, flush with clear water before eating, smoking, or touching your face or clothing. If battery acid splashes into your eyes, flush them out using clear water and obtain medical treatment immediately. Failure to do so may cause blindness.

Inspect the fuel tank in daylight. If a light is required, use a vapor-proof light. Do not permit open flames, sparks, smoking, or heated objects in the area during fueling.

The gasoline engine and water heater exhausts are lethal. Do not inhale these gases. A chemical-biological mask does not protect against carbon-monoxide. When the decontaminating apparatus is to be operated, the exhaust gases must be vented away from the operator and outside of an enclosed area to prevent carbon monoxide poisoning.

To avoid injury or electrical shock, keep the HEATER RECEPTACLE AND SWITCH on the pump unit control panel to OFF when the water heater is not in use. Avoid contact with the battery's positive contact at the starter solenoid when adjusting the belt tension. Electrical shock or damage to the equipment may result.

If it is necessary to disconnect the hoses with the water temperature at or above 100°F (38°C), exercise extreme care to prevent scalding.

For additional first aid data see FM 21-11.

Fire and explosion danger exist when dry cleaning solvent (SD) is used. Make sure that equipment is dry before operating.

**Operator's Manual
DECONTAMINATING APPARATUS, POWER-DRIVEN,
SKID-MOUNTED:
MULTIPURPOSE NONINTEGRAL
500-GALLON, M12A1
(NSN 4230-00-926-9488)
(EIC: 5FB)**

REPORTING ERRORS AND RECOMENDING IMPROVEMENTS

You can help improve this manual. If you find any mistakes or if you know of a way to improve the procedures, please let us know. Mail your letter, DA Form 2028 (Recommended Changes to Publications and Blank Forms), or DA Form 2028-2 located in the back of this manual direct to: Director, Armament and Chemical Acquisition and Logistic Activity (ACALA), ATTN: AMSTA-AC-NML, Rock Island, IL 61299-7630. (E-mail: AMSTA-AC-NML@ria-emh2.army.mil).

TABLE OF CONTENTS

	Page
HOW TO USE THIS MANUAL.....	iii
CHAPTER 1 INTRODUCTION.....	1-1
Section I General Information.....	1-1
Section II Equipment Description	1-2
CHAPTER 2 OPERATING INSTRUCTIONS.....	2-1
Section I Description and Use of Operator's Controls and Indicators.....	2-1
Section II Preventive Maintenance Checks and Services (PMCS)	2-16
Section III Operation Under Usual Conditions	2-57
Section IV Operation Under Unusual Conditions	2-134

	Page
CHAPTER 3	MAINTENANCE INSTRUCTIONS 3-1
Section I	Lubrication Instructions 3-1
Section II	Troubleshooting Procedures 3-4
Section III	Maintenance Procedures 3-14
APPENDIX A	REFERENCES A-1
APPENDIX B	COMPONENTS OF END ITEM LIST AND BASIC ISSUE ITEMS LIST B-1
APPENDIX C	ADDITIONAL AUTHORIZATION LIST (AAL) C-1
APPENDIX D	EXPENDABLE/DURABLE SUPPLIES AND MATERIALS LIST D-1
	ALPHABETICAL INDEX Index-1

HOW TO USE THIS MANUAL

This manual is used by the operator to operate and maintain the decontaminating apparatus. You, the user, must familiarize yourself with the information contained in the major sections and appendixes of this manual before attempting to operate or maintain this equipment.

This manual is to be used with M12A1 units that have had Modification Work Order (MWO) 3-4230-209-50-1 applied or manufactured after Jan 85 (serial numbers 587-2683 and larger). Modified units are identified by a plate mounted near the M12A1 nameplate on the pump unit control panel.

If the equipment fails to function properly after following the approved procedures given in the manual, notify your immediate supervisor. Do not attempt to apply unauthorized repairs or parts; extensive damage may result.

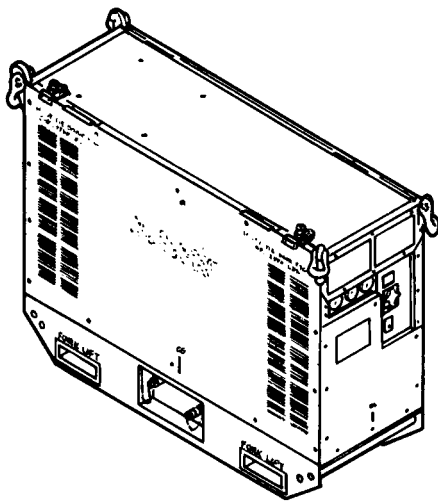

M2 SKID-MOUNTED, LIQUID FUEL
WATER HEATER

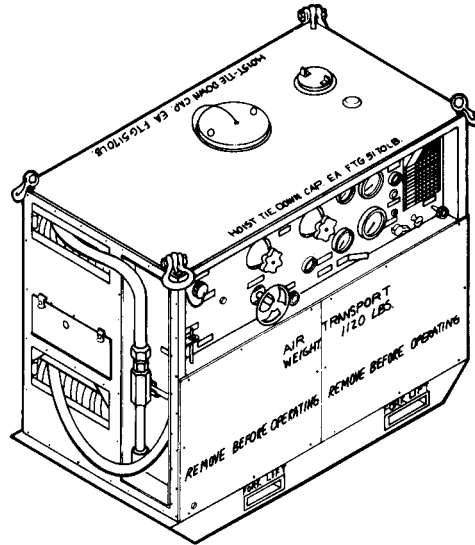

PUMP UNIT ASSEMBLY

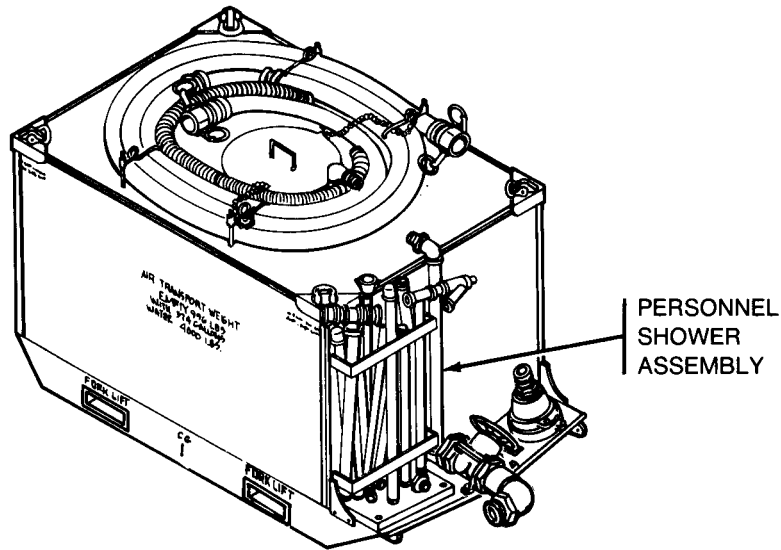

TANK UNIT ASSEMBLY

**ABC-M12A1 500 GALLON NONINTEGRAL MULTIPURPOSE, SKID-MOUNTED,
POWER-DRIVEN DECONTAMINATING APPARATUS**

**CHAPTER 1
INTRODUCTION**

Section I. GENERAL INFORMATION

1-1. SCOPE.

- a. *Type of Manual* Operators Manual, containing instructions for operation and operator (crew) maintenance.
- b. *Model Number and Equipment Name* The M12A1 Decontaminating Apparatus, Power Driven, Skid Mounted: 500-Gallon consists of:
 Decontaminating Apparatus (Skid-Mounted) Pumping Unit
 Decontaminating Apparatus Skid-Mounted Tank Unit
 Personnel Sectional Shower Assembly
 Liquid Fuel Water Heater
- c. *Purpose of Equipment* Provides the capability of spraying decontaminating materials, firefighting, deicing, cleaning vehicles, pumping various fluids, and showering personnel.
- d. This manual is to be used with M12A1 units that have had Modification Work Order (MWO) 34230-209-50-1 applied or manufactured after Jan 85 (serial numbers 587-2683 and larger). Modified units are identified by a plate mounted near the M12A1 nameplate on the pump unit control panel.

1-2. MAINTENANCE FORMS AND RECORDS Department of the Army forms and procedures used for equipment maintenance will be those prescribed by DA PAM 738-750, The Army Maintenance Management System (TAMMS).

1-3. REPORTING EQUIPMENT IMPROVEMENT RECOMMENDATIONS (EIR) your decontaminating apparatus needs improvement, let us know. Send us an EIR. You, the user, are the only one who can tell us what you don't like about your equipment. Let us know why you don't like the design. Tell us why a procedure is hard to perform. Put it on an SF 368 (Quality Deficiency Report). Mail it to us at: Commander, US Army Armament, Research, Development and Engineering Center, ATTN: AMSTA-AR-QAW-A (R), Rock Island, IL 61299-7300. We'll send you a reply.

1-4. NOMENCLATURE CROSS-REFERENCE LIST.

<i>Common Name</i>	<i>Official Nomenclature</i>
Blender hose assembly	Hose assembly
Decontaminating apparatus	Decontaminating Apparatus, Power-Driven, Skid-Mounted, 500-Gallon, M12A1
Hopper assembly	Liquid storage tank
Water heater	Heater, Water, Liquid Fuel,
Personnel shower assembly	Shower Assembly, Personnel Sectional
Pump unit	Pumping Unit, Multipurpose Nonintegral Decontaminating Apparatus (Skid-Mounted)
Tank drain valve	Regulating valve
Tank unit	Tank Unit, Decontaminating Apparatus Skid-Mounted

Section II. EQUIPMENT DESCRIPTION

1-5. EQUIPMENT CHARACTERISTICS, CAPABILITIES, AND FEATURES. The decontaminating apparatus is intended for field use. The pump, tank, personnel shower assembly, and water heater units are designed to be stationary or mobile and are used for spraying decontaminating materials, firefighting with water or foam, deicing, cleaning vehicles, pumping various fluids, and showering personnel. It is not authorized for use with defoliants, herbicides, or insecticides.

1-6. LOCATION AND DESCRIPTION OF MAJOR COMPONENTS.

a. Pump Unit.

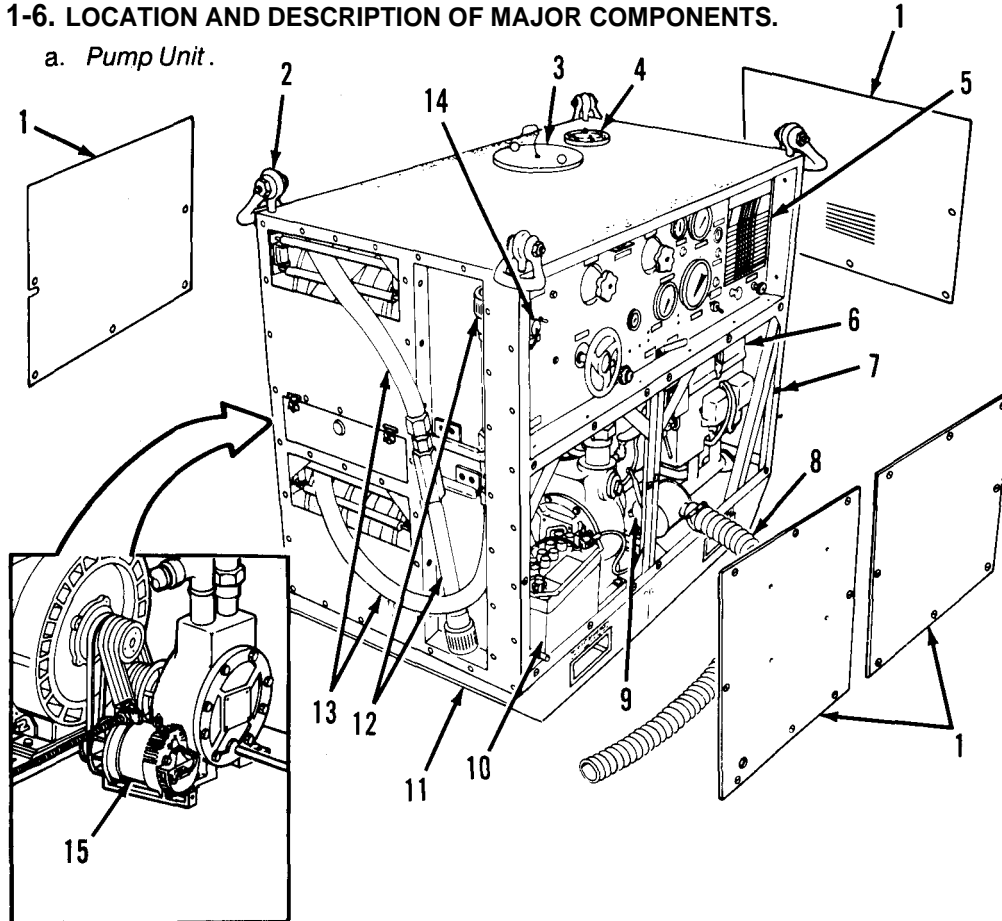

COVER PANELS (1). Fitted sheet-metal, quick-release removable panels protect the pump unit from the elements. When removed, the panels give access to components and ventilate the gasoline engine.

LIFTING EYE ASSEMBLY (2). Four lifting eyes, on top of the pump unit are used to pick up the pump unit assembly.

PRIME DETERGENT TANK AND LID (3). The 10-gallon prime-detergent tank is used to prime the pump, to store detergent for cleaning or to store foam for firefighting. The lid prevents foreign objects from entering prime detergent tank.

FUEL TANK AND FUEL TANK CAP (4). The 20-gallon fuel tank stores gasoline for the engine. The fuel tank cap has an internal selector valve. When open, the valve vents the fuel tank. The cap prevents dirt and moisture from entering the fuel tank.

CONTROL PANEL (5). Contains all the gages and valves for operating the gasoline engine and for controlling pump delivery.

GASOLINE ENGINE (6). The 20 hp engine supplies power through two pulleys and four drive belts to drive the pump and through two pulleys and one drive belt to drive the alternator/generator.

FRAME ASSEMBLY (7). A welded steel frame that supports components of the pump unit.

EXHAUST PIPE EXTENSION (8). Two exhaust pipe extensions (stored on the tank unit assembly) attach to the exhaust ports on either side of the engine and pipe exhaust fumes away from the engine.

PUMP (9). Pumps fluids from water source to tank unit and then, if needed, to water heater. Also mixes detergent or foam from the prime detergent tank with water.

24-VOLT BATTERY (10). Provides electrical energy to start the engine.

SKID ASSEMBLY (11). Provides a base for the pump unit assembly, provides a means to forklift the entire unit.

GUN ASSEMBLIES (12). Consist of either a water, slurry, or foam nozzle on an extension pipe with a ball valve. Controls water flow.

DISCHARGE HOSES (13). Stored on the two hose reels. The hoses discharge fluid for decontamination, firefighting, or for showers.

HEATER RECEPTACLE AND SWITCH (14). The water heater's main electrical power cable connects to the socket receptacle on the pump unit control panel.

ALTERNATOR/GENERATOR (15). Supplies power to the water heater through the pump unit control panel. Does not recharge the 24-volt battery while the equipment is operating.

TM 3-4230-209-10

b. Tank Unit and Personnel Shower Assembly.

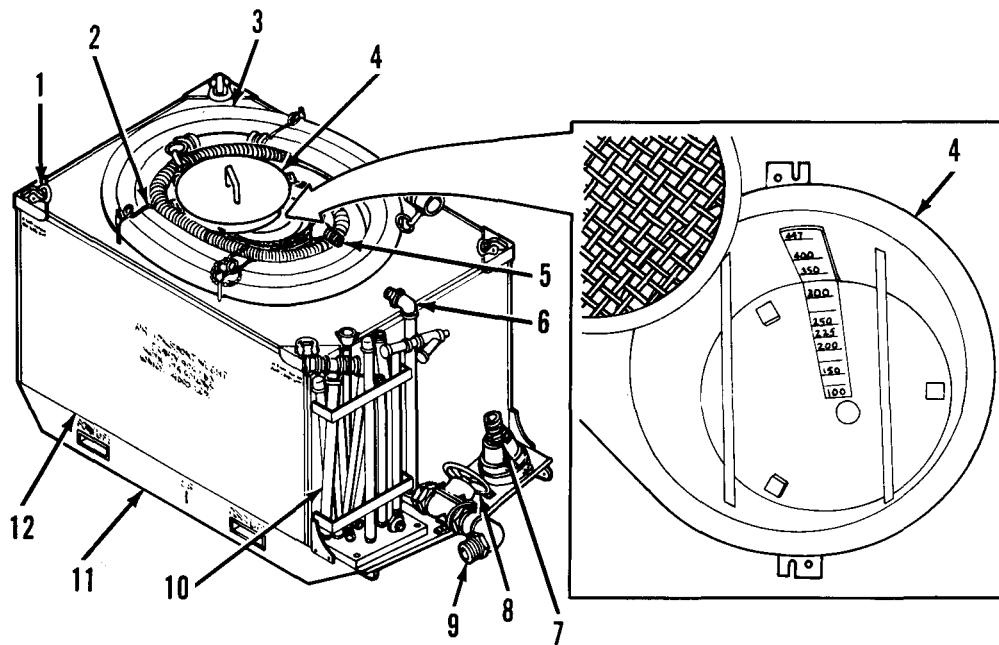

LIFTING EYE ASSEMBLY (1). Four lifting eyes, on the top of the tank unit, are used to pick up the tank unit.

BRACKET CLAMP (2). Secures the suction and exhaust hoses on top of the tank unit when not in use.

SUCTION HOSE (3). Carries water from the tank unit through the tank drain valve or from a natural source to the pump unit.

HOPPER-BLENDER ASSEMBLY AND COVER (4). The hopper-blender assembly along with a fluid agitation system in the tank blends decontaminating agent with water. The cover prevents foreign objects from entering the hopper-blender assembly.

BLENDER PIPE (5). Uses water from the pump unit to blend agents in the hopper-blender assembly.

AGITATOR PIPING (6). Uses water from the pump unit to agitate slurry in the tank unit assembly and is the passage for heated water from the heater unit.

FOOT VALVE ASSEMBLY (7). Prevents objects from clogging the suction hose when water is being pumped from a natural source. Clogs could damage the pump.

TANK DRAIN VALVE (8). Drains the tank unit.

HOSE ADAPTER (9). Provides for quick disconnect of the suction hose.

PERSONNEL SHOWER ASSEMBLY (10). Consists of pipes, couplings, and adapters. When connected, they form a field shower to mass shower personnel in the field. When dismantled, it is stowed on the tank unit.

TANK UNIT SKID (11). Provides a base for the tank unit and provides a means to forklift tank unit.

TANK ASSEMBLY (12). Has a volume of 500 gallons and a maximum working capacity of approximately 447 gallons of water. Working capacity for the tank with slurry mix is 317 gallons.

TM 3-4230-209-10

c. Water Heater

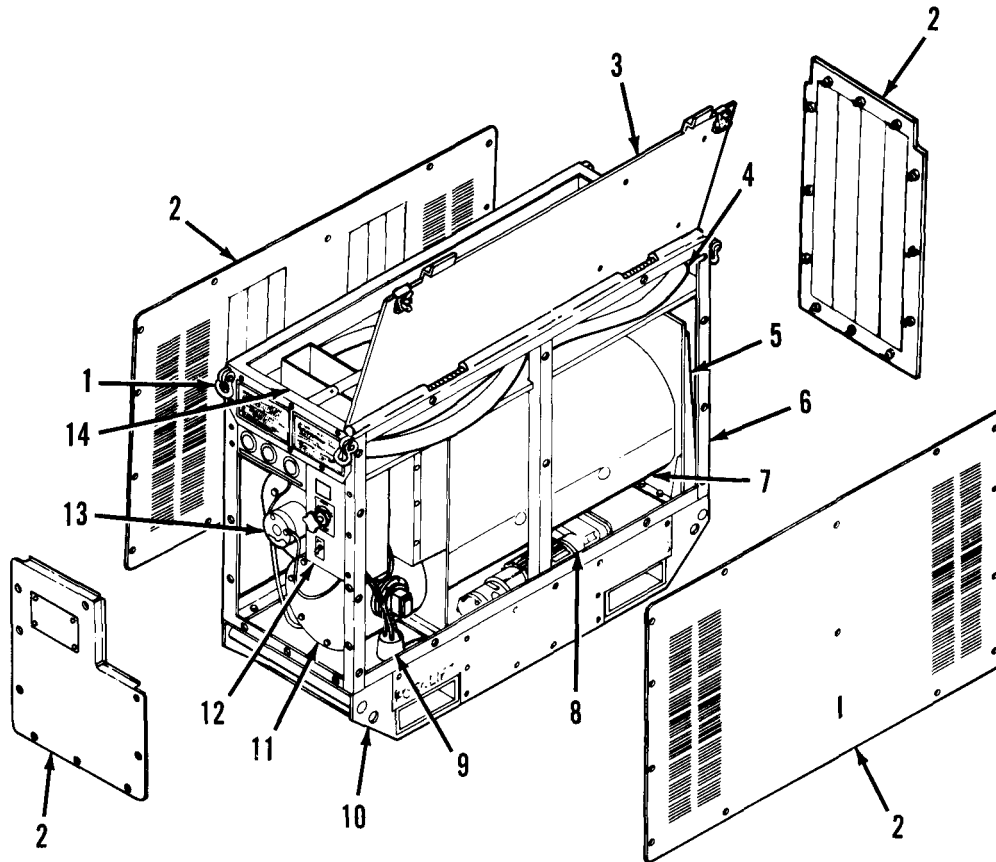

LIFTING EYE ASSEMBLY (1). Four lifting eye assemblies are used to pickup the water heater.

COVER PANELS (2). Fitted sheet-metal, quick-release removable panels protect the water heater from the elements. When removed, the panels give access to components.

COVER (3). When heater is not used, the cover protects the water hoses, fuel hose assembly, power cable and keeps rain out of the boiler heater. When the heater is used, the cover must be open so exhaust gases can be vented through the top of the heater. A canvas tool carrier is also attached inside of cover.

HOSE AND CABLE STORAGE COMPARTMENTS (4). Stores power cable assembly, fuel hose and filler opening assembly, and water hose assembly.

REFRACTORY BOX (5). Evenly distributes heat from the combustor ignited fuel air mixture from the boiler into the heat exchange tubing, where most of the heat exchange takes place.

FRAME (6). A welded steel frame that serves as a mount for components of the water heater.

BOILER (7). A holding tank for heating water.

FUEL PUMP AND IGNITION DRIVE MOTOR (8). 24 Vdc. Prime mover for the fuel pump and the combustor ignition magneto.

FUEL SOLENOID VALVE (9). Controls the flow of fuel through the solenoid valve body to the heater or back to the fuel source.

SKID ASSEMBLY (10). Provides a base for the water heater and a means to forklift the entire unit.

COMBUSTOR ASSEMBLY(11). In the combustor assembly the combustor igniter ignites an atomized fuel mixture and forced air from the blower motor and then drives the burning fuel-air mixture through the boiler.

CONTROL PANEL (12). Contains TEMPERATURE SELECTOR valve, HEATER ON/PURGE ON SWITCH, WATER PRESSURE, FUEL PRESSURE and WATER TEMPERATURE gages, and a TEMPERATURE SELECTOR CAUTION plate.

COMBUSTION AIR BLOWER MOTOR (13). Forces air into the combustor assembly.

EXHHAUST STACK (14). Exhaust heat and fumes from the combustor assembly.

TM 3-4230-209-10

1-7. EQUIPMENT DATA.

a. Weights and Dimensions.

<i>Components</i>	<i>Length in./mm</i>	<i>Width in. /mm</i>	<i>Height in./mm</i>	<i>Weight (approx) lbs/kg</i>	<i>Cubic Feet</i>
Pump unit (crated)	61/1550	39/990	58/1430	1,770/803	81
(uncrated)	56/1430	32/813	51/1300	1,120/508	52
Tank unit (crated)	88/2240	53/1320	67/1 700	1,690/767	153
(uncrated)	82/2080	45/1140	51/1300	996/452	102
Water (crated)	57/1450	24/610	47/1190	731/332	37
Heater (uncrated)	53/1350	21/530	43/1100	575/261	22

b. Tabulated Data.

TANK UNIT

Working capacity, water only	447 gal (1692 liters)
STB decontaminating agent(slurry).	317 gal (1200 liters)
Water (per filling for slurry).	225 gal (851.63 liters)
STB decontaminating agent per filling (dry).	1,300 lb (590 kg)
M2 antiset compound per filling (dry)	12-1/2 lb (5.68 kg)
Weight of 317 gallon slurry mixture	3.170 lb (1,437.89 kg)

NOTE

When being airlifted by UH-1H aircraft, the tank unit (996 lbs empty) plus the water must weigh less than 4,000 pounds (1,814.37 kg). Fill the tank unit with no more than 374 gallons (1,415.59 liters) of water for airlift operations. When being airlifted by UH-60A aircraft, the tank unit weight is limited to 7,000 lbs. However, when the tank unit is airlifted by CH-47 aircraft, the tank weight is unlimited.

SPACE REQUIREMENTS

Pump Unit	15 sq ft(1.4 sq m)
Tank Unit25 sq ft (2.3 sq m)
Water Heater	20 sq ft (1.8 sq m)

CENTRIFUGAL PUMP

Capacity50 gpm (189.27 lpm)
Pressure60-120 psi (42, 186-84, 372 kg/sq m)

TANK CAPACITIES (PUMP UNIT)

Prime-Detergent tank 10 gal (37.85 liters)
 Gas tank 20 gal (75.70 liters)

APPROXIMATE TIME REQUIRED FOR LOADING AND MIXING

Loading tank with water (after priming) 50 gpm (189.25 lpm)
 Loading tank with antiset 1 min
 Mixing antiset with water 2 min
 Loading tank with antifoam 1 min
 Mixing antifoam with water 2 min
 Loading tank with STB decontaminating agent 35 min
 Agitation continuous

ENGINE, GASOLINE, Model 4A084-3. Refer to TM 9-2805-259-14.

Weight 265 lbs/122.5 kg

WATER HEATER

Electrical input 24V dc
 Maximum operating water pressure 200 psi (126558 kg/sq m)
 Maximum operating water temp 200°F (93.3°C)

COMPONENT AND NATIONAL STOCK NUMBER

Pump unit NSN 4230-00-902-3225
 Tank unit NSN 4230-00-735-9931
 Water heater NSN 4410-00-542-5656

CHAPTER 2 OPERATING INSTRUCTIONS

Section 1. DESCRIPTION AND USE OF OPERATOR'S CONTROLS AND INDICATORS

2-1. GENERAL. Table 2-1 describes the controls and indicators used to operate the decontaminating apparatus. The controls and indicators are located on the pump unit control panel, the water heater control panel, and the tank unit.

Table 2-1. OPERATOR'S CONTROLS AND INDICATORS

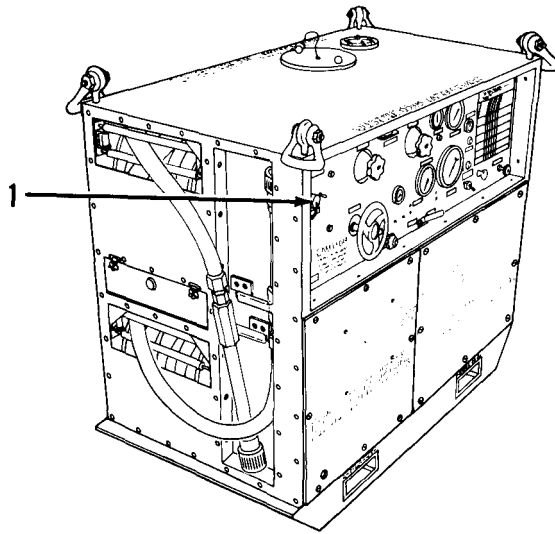

Key	Control or Indicator	Function
1	HEATER RECEPTACLE AND SWITCH on Pump Unit	<p style="text-align: center;">Pump Unit Control Panel</p> <p>Supplies power to operate the water heater.</p> 

Table 2-1. OPERATOR'S CONTROLS AND INDICATORS (CONT)



Key	Control or Indicator	Function
Pump Unit Control Panel (Cont)		
2	VALVE NO. 2 LOWER REEL	<p>Diaphragm valve. Controls the flow of liquids from the upper manifold to the lower hose reel discharge hose.</p> 
3	CIRCUIT BREAKER	<p>Starting circuit overload protection. Move to ON position before starting unit, and to reset.</p> 

Key	Control or Indicator	Function
4	VALVE No. 3 UPPER REEL	Diaphragm valve. Controls the flow of liquid from the upper manifold to the upper hose reel discharge hose. <div data-bbox="707 470 1194 927" data-label="Diagram"> </div>
5	FUEL INDICATOR switch	Pressed and held into register the amount of fuel in the fuel tank.
6	Fuel quantity gage	Registers the amount of fuel in the fuel tank when the fuel indicator switch is pressed and held in. <div data-bbox="799 1289 1244 1630" data-label="Diagram"> </div>

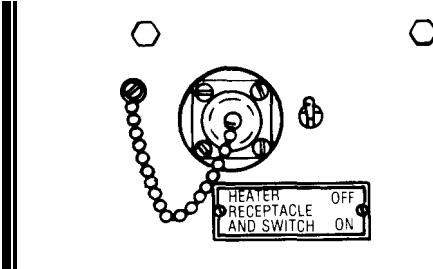
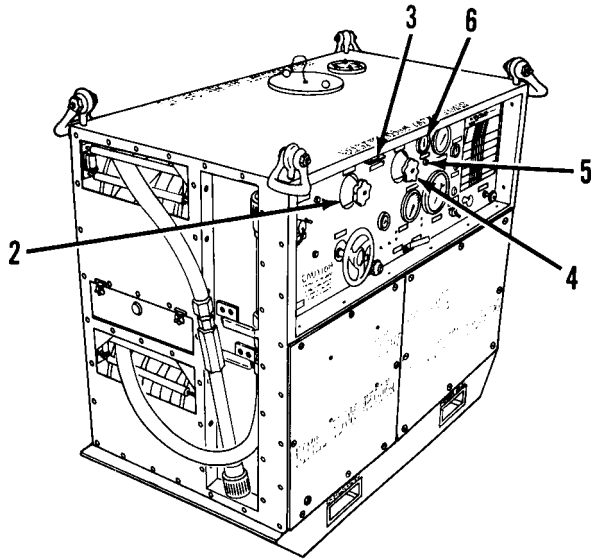
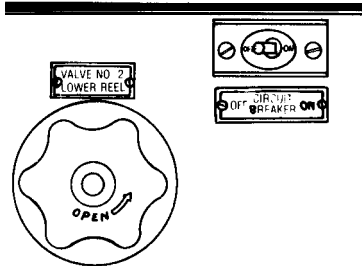
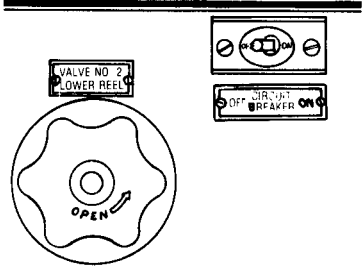
Table 2-1. OPERATOR'S CONTROLS AND INDICATORS (CONT)

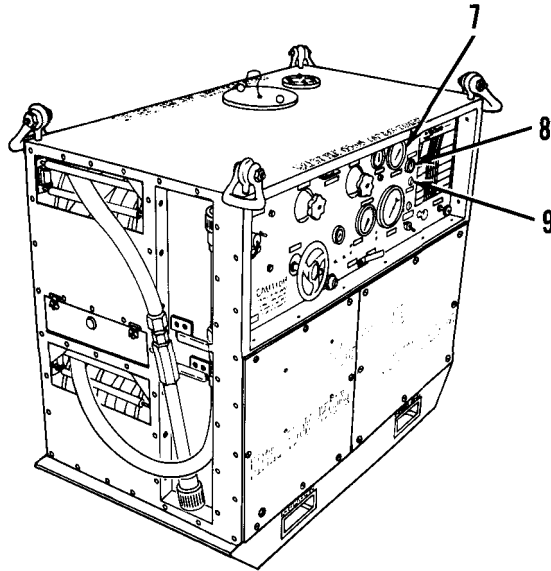

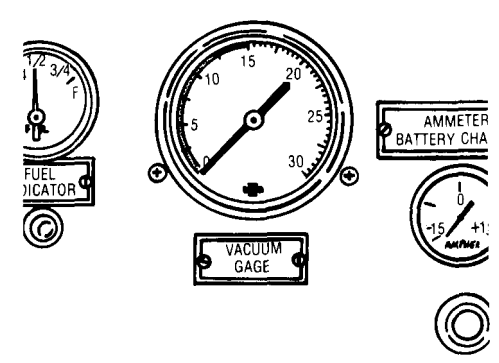
Key	Control or Indicator	Function
Pump Unit Control Panel (Cont)		
7	VACUUM GAGE	<p>Indicates the intake vacuum of the pump in inches of mercury (0-30).</p> <hr style="width: 200px; margin: 10px auto;"/> 

Key	Control or Indicator	Function
8	<p>AMMETER BATTERY CHARGE</p>	<p>Measures and registers the amount of direct current that is charging the battery.</p> 
9	<p>GENERATOR warning light</p>	<p>Indicates that the engine alternator is generating an alternating current. This does not mean that this current is charging the battery.</p> 

Table 2-1. OPERATOR'S CONTROLS AND INDICATORS (CONT)



Key	Control or Indicator	Function
Pump Unit Control Panel (Cont)		
10	FUEL SHUT OFF valve	<p>Controls the flow of fuel from the fuel tank to the engine carburetor.</p> 
11	CHOKE	<p>Chokes engine to ease engine starting.</p> 

Key	Control or Indicator	Function
12	OIL PRESSURE SWITCH	<p>Is a manually operated, push-to-open switch. The engine is started by depressing the OIL PRESSURE SWITCH while holding the start magneto switch to START. The OIL PRESSURE SWITCH must be depressed until the oil PRESSURE GAGE indication exceeds 20 psi or the engine will stop running.</p>
13	Start magneto switch	<p>Three position (STOP, RUN, and START) rotary switch. Controls starter and ignition power to the engine.</p>  <p>The diagram shows a partial view of a pressure gauge on the left with markings at 210, 240, 270, and 300. To its right is a rectangular switch labeled 'GENERATOR'. Below the generator switch is a circular indicator. In the center is a rectangular switch labeled 'OIL PRESSURE SWITCH' with 'STOP RUN START' written below it, and a key is shown inserted into its bottom. To the right of the oil pressure switch is a circular knob labeled 'CHOKE'. On the far right is a vertical panel with several horizontal slots.</p>
14	Water PRESSURE GAGE	<p>Indicates the pump discharge pressure in psi (0-300).</p>  <p>The diagram features a large circular pressure gage with a scale from 0 to 300 psi in increments of 30. The needle points to approximately 180 psi. Below the gage is a rectangular label 'PRESSURE GAGE'. To the right of the gage is a rectangular switch labeled 'GENERATOR'. Below the generator switch is a circular indicator. To the right of that is another rectangular switch labeled 'OIL PRESSURE SWITCH' with 'STOP RUN ST' written below it, and a key is shown inserted into its bottom. There are also two small circular indicators to the left of the pressure gage.</p>

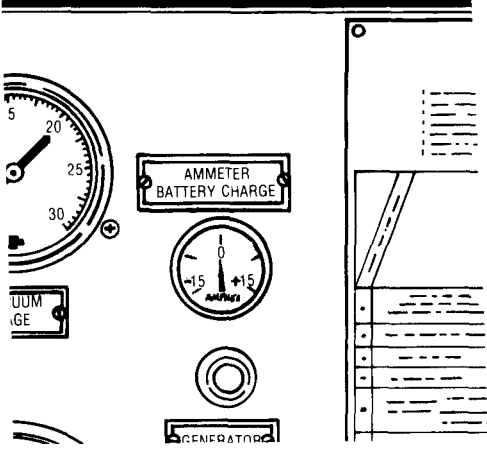
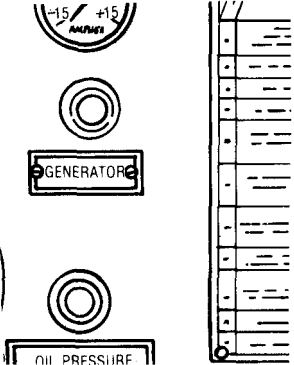
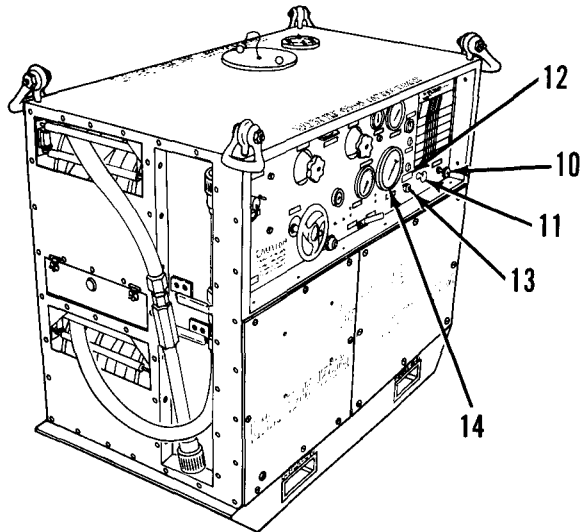
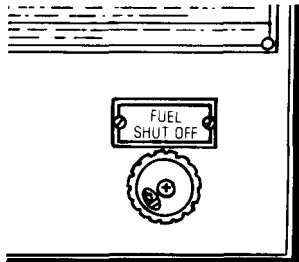
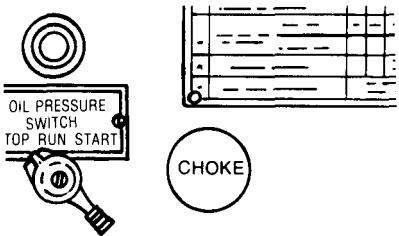
Table 2-1. OPERATOR'S CONTROLS AND INDICATORS (CONT)



Key	Control or Indicator	Function
Pump Unit Control Panel (Cont)		
15	TACHOMETER-hourmeter	<p>The TACHOMETER indicates engine speed in rpm. The hourmeter indicates total running time of the pump and the engine.</p> 
16	VALVE NO. 4 PRIME	<p>Controls flow of liquid from the prime-detergent tank through the eductor to the pump.</p> 

Key	Control or Indicator	Function
17	Oil pressure gage	<p data-bbox="640 357 1313 421">Indicates the engine oil pressure in psi. The engine will not operate if the oil pressure is below 20 psi.</p> 
18	Throttle	<p data-bbox="640 708 1313 836">Controls engine speed. For full throttle, press knob in as far as it will go toward panel. To decrease engine rpm, pull out the knob. For fine adjustment of engine rpm, turn the knob. Use button lock to keep throttle at one setting.</p> 
19	VALVE NO. 1 MANIFOLD	<p data-bbox="640 1155 1263 1219">Offset diaphragm valve selects the routing of liquid discharged by the pump.</p> 

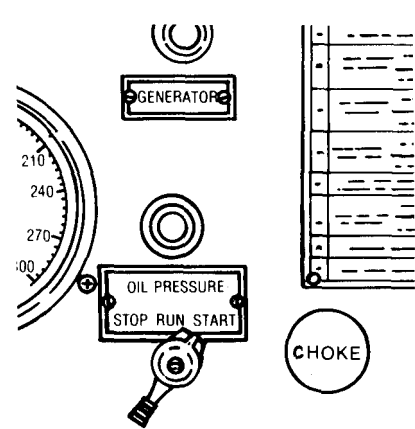
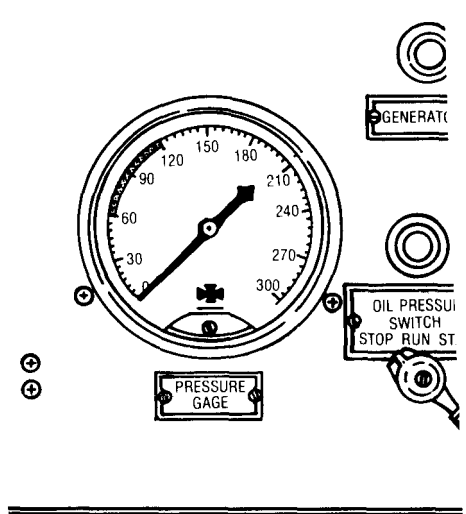
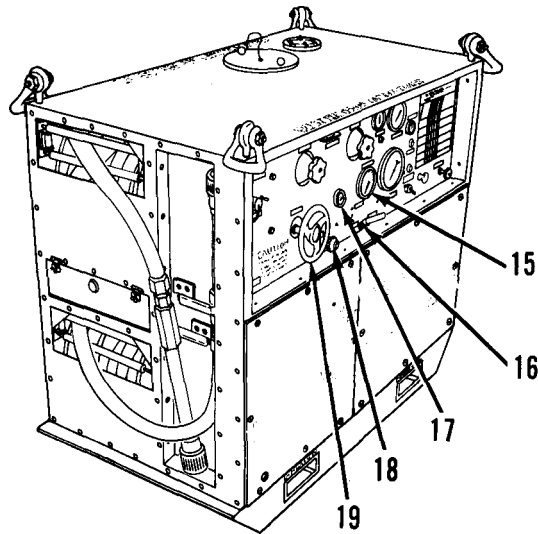
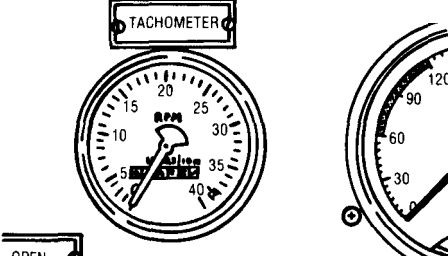
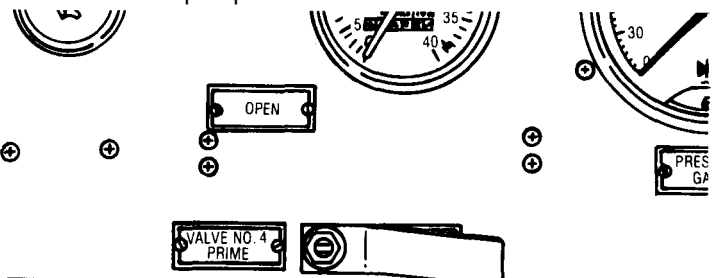
Table 2-1. OPERATOR'S CONTROLS AND INDICATORS (CONT)



Key	Control or Indicator	Function
Pump Unit Control Panel (Cont)		
20	Pump DRAIN valve	Ball valve controls liquid draining from the pump.
21	Pump DRAIN valve CAUTION	<p>Alerts user to keep the pump DRAIN valve OPEN when the equipment is not in operation to prevent water from freezing in the pump.</p> 

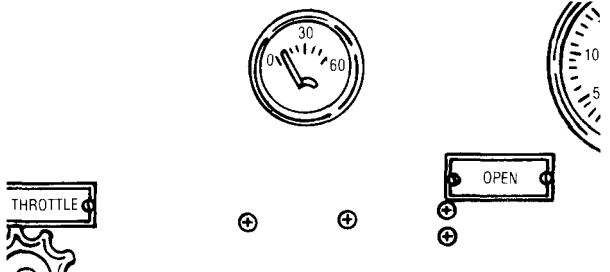
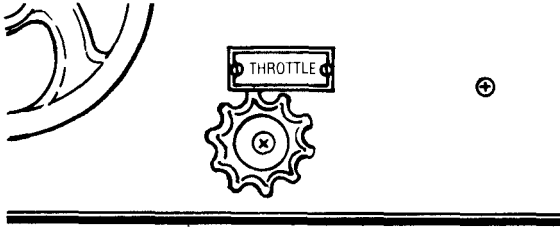
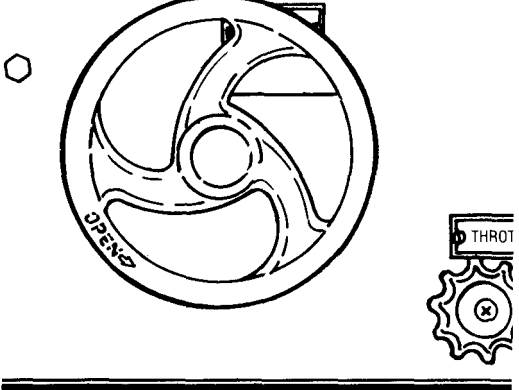
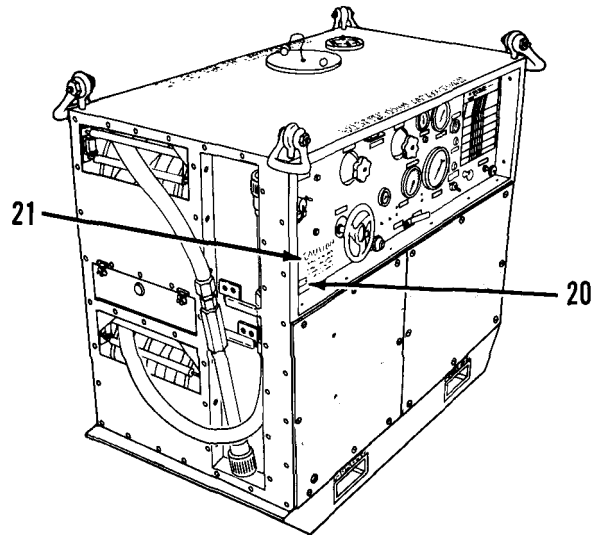
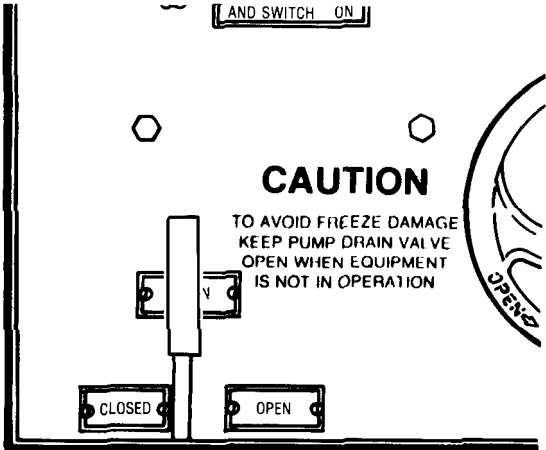
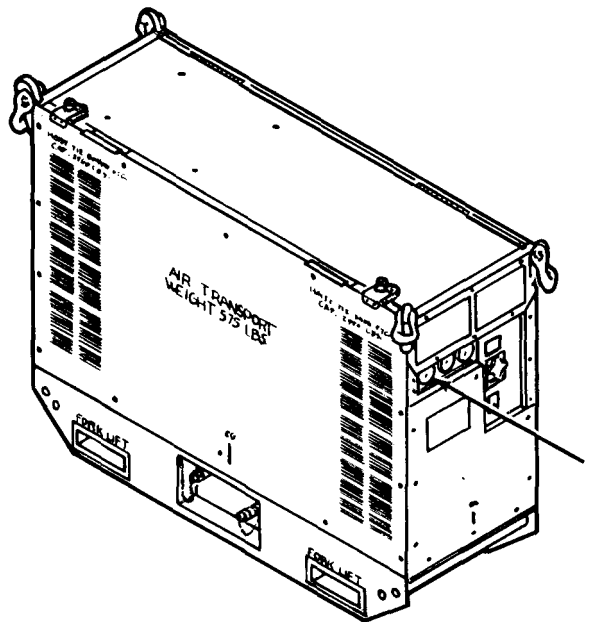

Key	Control or Indicator	Function
1	WATER PRES-SURE gage	<p data-bbox="674 1093 987 1123">Water Heater Control Panel</p> <p data-bbox="640 1157 1334 1315">Indicates the pressure of the water being circulated through the boiler. Normal pressure indications are 60-155 psi. When the pressure exceeds 200 psi, the pressure relief valve (safety valve) on the boiler opens and relieves excess pressure.</p> <div data-bbox="778 1370 1207 1676" style="border: 1px solid black; padding: 5px; margin: 10px auto; width: fit-content;"> </div>

Table 2-1. OPERATOR'S CONTROLS AND INDICATORS (CONT)

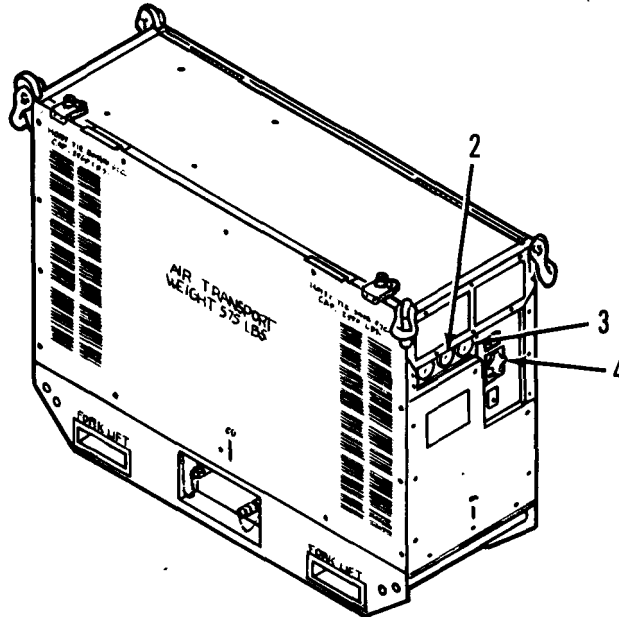

Key	Control or Indicator	Function
2	FUEL PRESSURE gage	<p>Water Heater Control Panel (Cont)</p> <p>Indicates pressure of the fuel supply. Since the water heater has a multifuel capability, different fuel pressures are required as follows: gasoline -75 psi; turbine fuel - JP4 or JP5 -75 psi; kerosene -70 psi; and No. 2 diesel or fuel oil - 60 psi.</p> <div data-bbox="716 1321 1174 1634" style="text-align: center;"> <p>WATER PRESSURE FUEL PRESSURE WATER TEMPERATURE</p> </div>

Key	Control or Indicator	Function
3	WATER TEMPERATURE gage	Indicates the temperature of the water in the boiler. 
4	TEMPERATURE SELECTOR control valve	Sets the desired operating water temperature manually. Turn the knob clockwise to raise the water temperature. Turn the knob counterclockwise to lower the water temperature. Increasing water temperature will increase fuel pressure. 

Table 2-1. OPERATOR'S CONTROLS AND INDICATORS (CONT)



Key	Control or Indicator	Function
5	HEATER ON/ PURGE ON switch	<p>Water Heater Control Panel (Cont)</p> <p>Controls operation of water heater. Placing the switch to PURGE ON energizes the fuel and ignition drive motor. Placing the switch to HEATER ON closes the fuel pump solenoid valve, admits fuel into the combustion chamber, and fires the boiler. Placing the switch to PURGE ON circulates fuel through the fuel pump and back to supply. There is no off position on this switch.</p> <div style="text-align: center;"> </div>

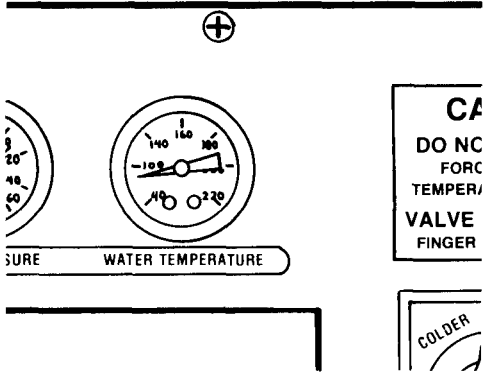
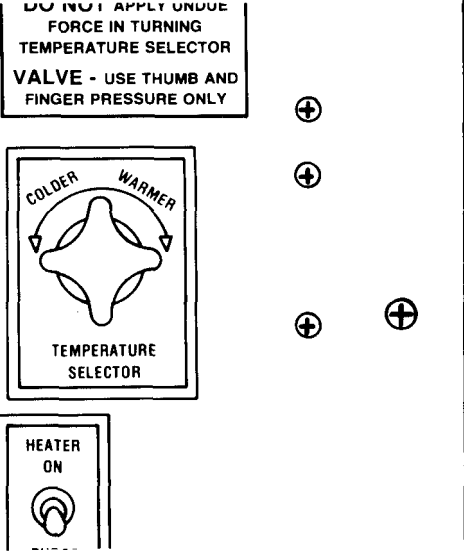
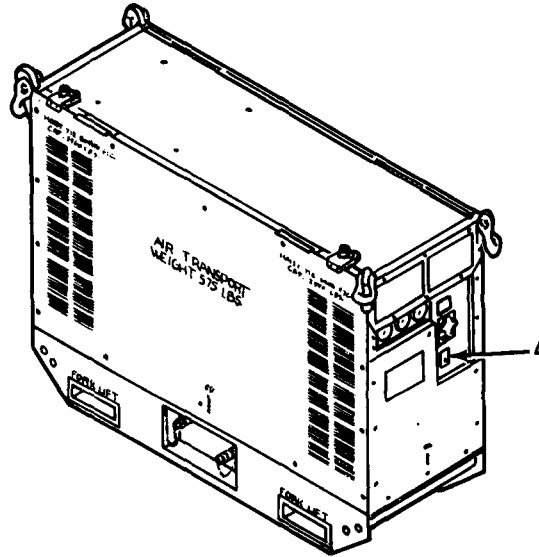
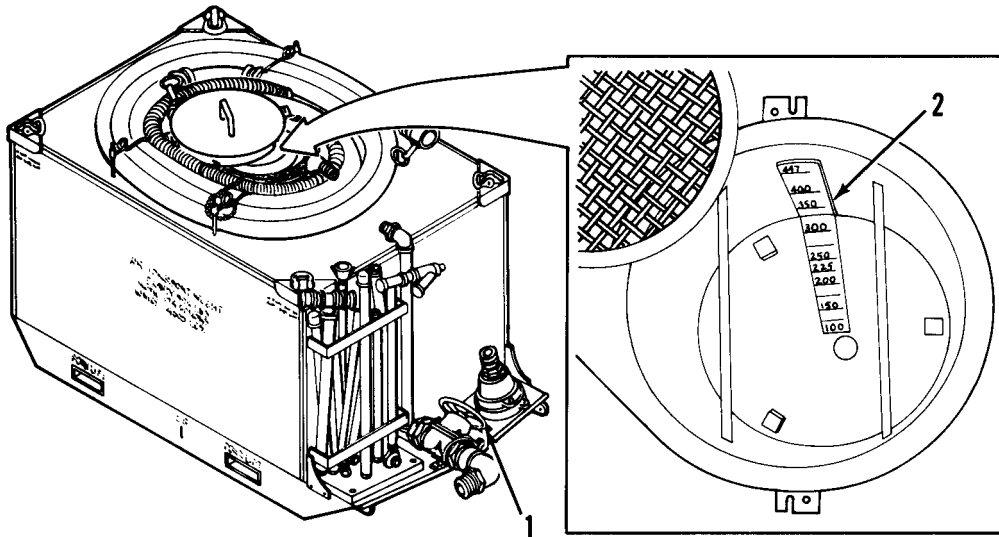

Key	Control or Indicator	Function
		Tank Unit Controls
1	Tank drain valve	Drains liquids or slurry from the tank.
2	Tank liquid level indicator	Located in the hopper-blender. The indicator is scaled from 100-447 gallons and shows the volume of liquid in the tank unit.

Section II. PREVENTIVE MAINTENANCE CHECKS AND SERVICES (PMCS)

2-2. GENERAL.

- a. *Before.* Checks and services performed prior to the equipment leaving its containment area or performing its intended mission. Always keep in mind the CAUTIONS and WARNINGS. Perform your BEFORE PMCS.
- b. *During.* Checks begin when the equipment is being used in its intended mission. Always keep in mind the CAUTIONS and WARNINGS. Perform your DURING PMCS.
- c. *After.* Checks and services begin when the equipment is taken out of its mission mode or returned to its containment area. Be sure to perform your AFTER PMCS.
- d. *Quarterly.* Perform quarterly checks and services every 90 days unless equipment is in permanent storage.
- e. *If Your Equipment Fails To Operate* Troubleshoot with proper equipment. Report any deficiencies with the proper forms. See DA PAM 738-750.

2-3. PMCS PROCEDURES.

- a. *General.* Table 2-2 contains operator's PMCS procedures. The procedures are arranged in a logical sequence requiring a minimum amount of time and motion on the part of the person(s) performing them and are arranged so there will be a minimum of interference between person(s) performing checks simultaneously on the same end item.
- b. *Item No. Column* Checks and services are numbered in chronological order regardless of interval. Use this column as a source of item numbers for the "TM Number" column on DA Form 2404, Equipment Inspection and Maintenance Worksheet, in recording results of PMCS.
- c. *Interval Column* The words in the Interval column indicate when the checks or services are to be done as follows:
 - (1) If a given check is performed before, during, or after an operation, the word BEFORE, DURING or AFTER will be in this column, respectively.
 - (2) If the same check is made at two or more intervals, the appropriate words will appear in the column.
- d. *Location, Item to Check/Service Column* Indicates location and/or the item to be checked and/or serviced. The items to be inspected are identified by as few words, usually the common name, as will clearly identify the item, e.g., "Drive Belts."
- e. *Procedure Column* This column briefly describes the procedure by which the check is performed. It contains all the information required to perform the checks and services, including appropriate tolerances, adjustment limits, and instrument gage readings.
- f. *Not Fully Mission Capable If: Column* This column contains the criteria that will cause the equipment to be classified as not mission capable because of inability to perform its primary mission. An entry in this column will:
 - (1) Identify conditions that make the equipment not mission capable for readiness reporting purposes.
 - (2) Deny use of the equipment until corrective maintenance has been performed.

Table 2-2. OPERATOR'S PREVENTIVE MAINTENANCE CHECKS AND SERVICES (PMCS)

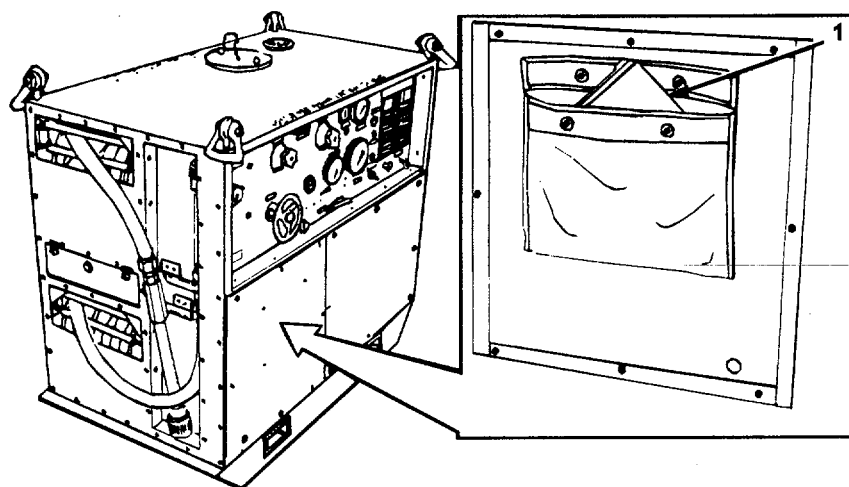

Item No.	Interval	Location, Item to Check/Service	Procedure	Not Fully Mission Capable If:
1	BEFORE	Publications	<p>NOTE Within designated interval, perform these checks in the order listed.</p> <p>See that TM 3-4230-209-10, TM 9-2805-259-14, LO 9-2805-259-12, and LO 3-4230-209-10 are present in the canvas pouch on the pump unit cover panel and are usable. Insure all URGENT MWO's have been applied.</p> <p>NOTE Check continuously for evidence of leaks, loose or missing hardware, bolts, nuts, or clamps, and unusual noises.</p>	Any URGENT MWO's have not been applied.

Table 2-2. OPERATOR'S PREVENTIVE MAINTENANCE CHECKS AND SERVICES (PMCS) (CONT)

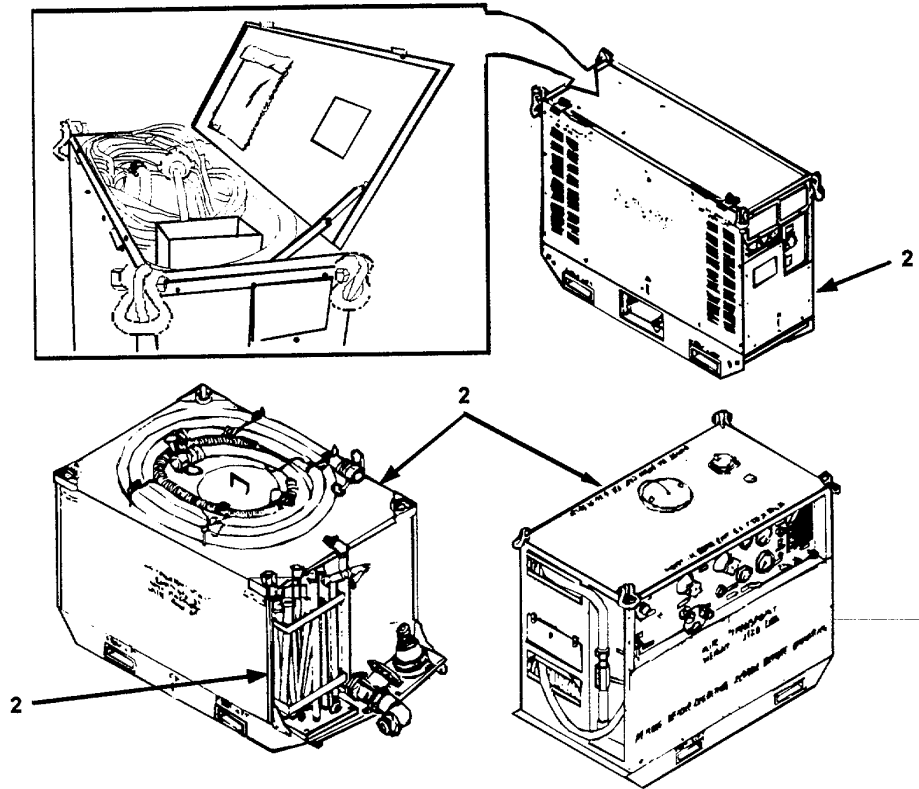

Item No.	Interval	Location, Item to Check/Service	Procedure	Not Fully Mission Capable If:
2	<p>BEFORE and QUARTERLY</p> <p>BEFORE and QUARTERLY</p> <p>BEFORE and QUARTERLY</p>	M12A1 Decon	<p>a. Make sure all of the on-board tools and required are in the tool carrier on the water heater or in the drawer between the pump unit upper and lower hose reels.</p> <p>b. Make sure two crank handles are in the drawer between the pump unit upper and lower hose reels.</p> <p>c. Check that the units are complete and undamaged.</p>	<p>spare parts</p> <p>One or more of the four units are incomplete damaged or inoperable.</p>

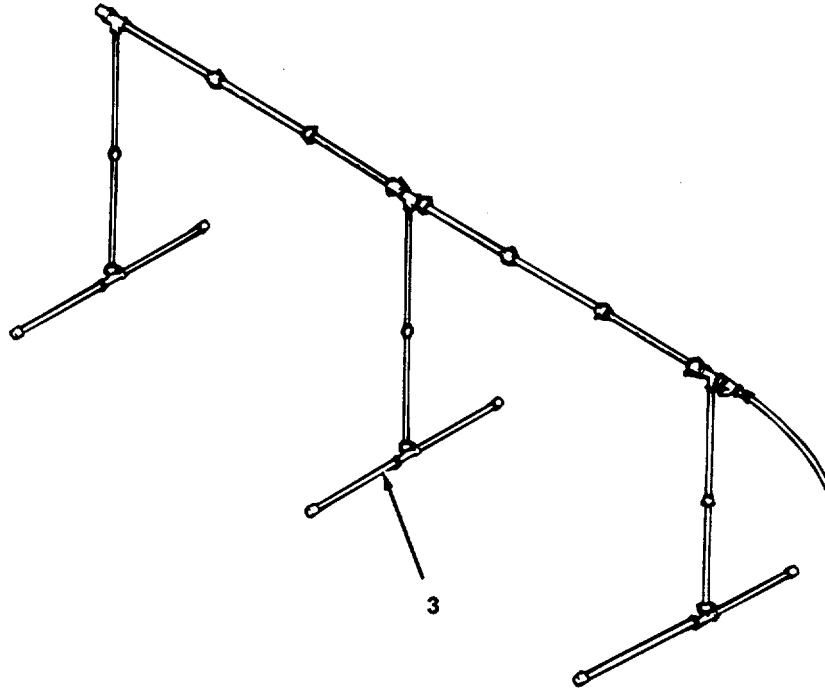

Item No.	Interval	Location, Item to Check/Service	Procedure	Not Fully Mission Capable If:
3	<p>BEFORE and QUARTERLY</p> <p>DURING</p> <p>AFTER</p>	Personnel Shower Assembly	<p>a. Inspect the exterior surfaces of the pipes and fittings for out of round and broken parts.</p> <p>b. Make sure the shower outlet holes in the six pieces of pipe are open.</p> <p>c. Remove pipe plug (1) from sediment strainer (2). Remove, clean, and replace screen (3).</p> 	<p>Parts are broken or out of round.</p> <p>Holes are clogged.</p> <p>Sediment strainer is clogged.</p>

Table 2-2. OPERATOR'S PREVENTIVE MAINTENANCE CHECKS AND SERVICES (PMCS) (CONT)



Item No.	Interval	Location, Item to Check/Service	Procedure	Not Fully Mission Capable If:
3	BEFORE QUARTERLY	Personnel Shower Assembly (Cont)	d. Check for missing or damaged gaskets. e. Inspect exterior surfaces of pipes and fittings for rust, corrosion, looseness, damage, cracks, or deformation. Remove external scale or rust with a wire brush (item 5, app D). Clean personal shower assembly with clear water. Repaint (item 21, app D) exterior surfaces if the paint is worn or chipped. When disassembling the personnel shower assembly, avoid damaging threads or burring the pipes or the fittings.	Gaskets are missing or

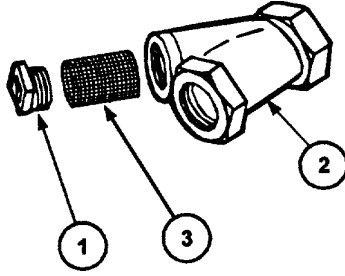
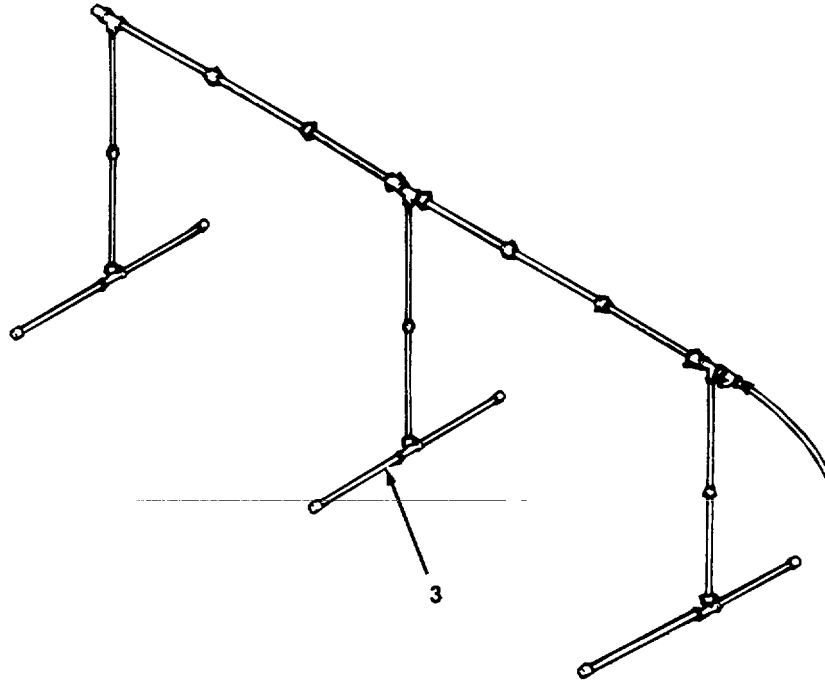
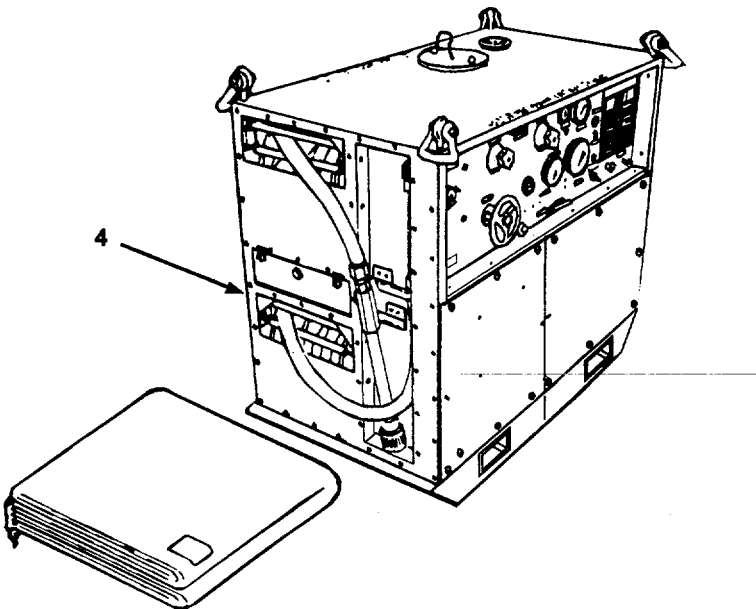

Item No.	Interval	Location, Item to Check/Service	Procedure	Not Fully Mission Capable If:
4	<p>QUARTERLY</p> <p>AFTER and QUARTERLY</p> <p>AFTER and QUARTERLY</p>	Pump Unit	<p>a. Inspect pump unit for rust or corrosion. Remove any rust or corrosion with wire brush (item 5, app D). Repaint pump unit with paint (item 21, app D).</p> <p>b. Inspect pump unit surfaces for cracks, dents, damage, and deformation.</p> <p>(1) Clean the exterior of the pump unit with hot, soapy water then rinse with clear water.</p> <p>(2) Lubricate according to LO 3-4230-20910.</p> <p>c. Inspect canvas cover to see that all buckles, snaps, and straps are in good condition and not corroded or damaged. If cover is unserviceable and needs to be replaced, notify organizational maintenance.</p>	

Table 2-2. OPERATOR'S PREVENTIVE MAINTENANCE CHECKS AND SERVICES (PMCS) (CONT)

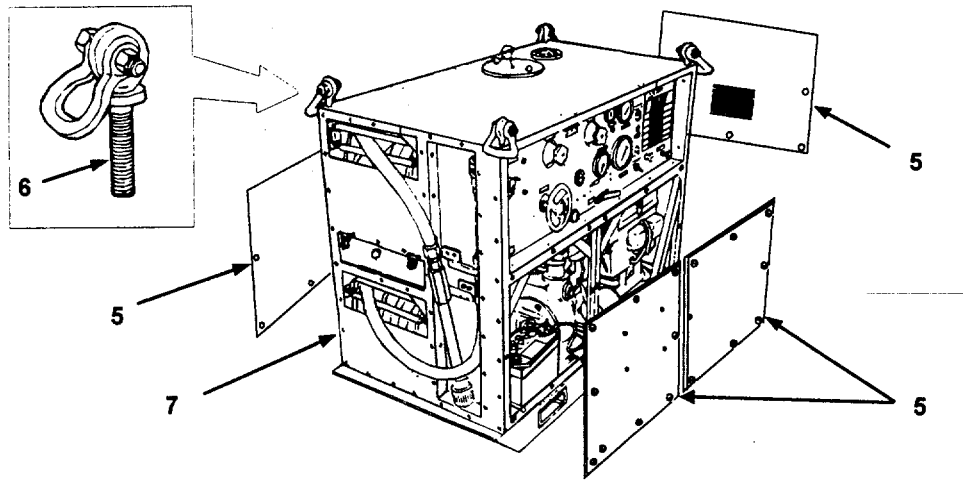

Item No.	Interval	Location, Item to Check/Service	Procedure	Not Fully Mission Capable If:
5	BEFORE AFTER QUARTERLY	Pump Unit (Cont) Cover Panels	<ul style="list-style-type: none"> a. Remove quick release panels and inspect panel gaskets for damage. Inspect panels for damage and cracks. b. Make sure the camlock fasteners securely lock the panels to the pump unit. c. Wash panels with hot soapy water and rinse with clear water. Remove any rust with wire brush (item 5, app D) and repaint (item 21, app D). 	
6	QUARTERLY	Clevis & Eyebolt Assemblies	<p>Check that the assemblies can be removed easily from the frame and are not damaged. Check for damaged threads. Make sure the clevis and eyebolt assemblies are securely in place and are free of burrs, cracks.</p> <ul style="list-style-type: none"> a. Inspect for damage, rust, or corrosion. 	
7	QUARTERLY	Pump Unit Assembly	<ul style="list-style-type: none"> a. Inspect for damage, rust, or corrosion. 	

Item No.	Interval	Location, Item to Check/Service	Procedure	Not Fully Mission Capable If:
	BEFORE		b. Check that instruction and identification plates are legible.	Instruction and identification plates are illegible.
	QUARTERLY		<p style="text-align: center;">WARNING</p> <p>Fire and explosion danger exist when dry cleaning solvent (SD) is used. Make sure that equipment is dry before operations begin.</p> <p>c. Clean unpainted metal parts and interior of pump unit assembly with a cloth dampened with dry cleaning solvent (item 10, app D). Dry interior of pump unit assembly thoroughly. Use hot, soapy water and a brush to remove hardened slurry or dirt from the exterior surfaces.</p> <p>d. When necessary tighten hardware and connections. See that wiring and other objects do not obstruct moving parts.</p>	
	BEFORE			

Table 2-2. OPERATOR'S PREVENTIVE MAINTENANCE CHECKS AND SERVICES (PMCS) (CONT)

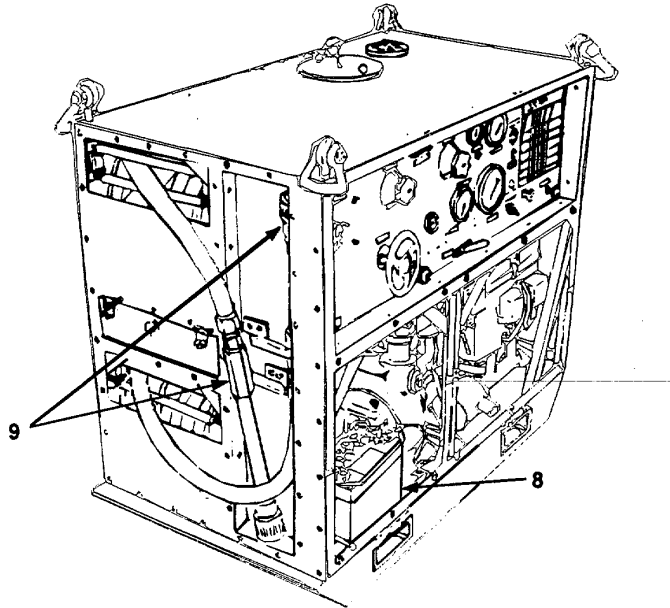

Item No.	Interval	Location, Item to Check/Service	Procedure	Not Fully Mission Capable If:
8	BEFORE and QUARTERLY	Pump Unit Assembly (Cont) Battery	a. See that the battery is fully charged. See that the positive and ground cables are attached properly to the battery terminals and to the engine. See that the battery is fastened tightly to the pump unit skid.	Battery is unserviceable or improperly attached.

Item No.	Interval	Location, Item to Check/Service	Procedure	Not Fully Mission Capable If:
9	<p>BEFORE and QUARTERLY</p> <p>BEFORE and QUARTERLY BEFORE and QUARTERLY BEFORE</p> <p>BEFORE and QUARTERLY</p> <p>QUARTERLY</p>	<p>Gun Assembly and Slurry Nozzle Assembly</p>	<p>b. Check electrolyte level. If electrolyte is not filled to ledge in filler opening, notify unit maintenance.</p> <p>c. Check that vent holes in vent caps are clear.</p> <p>d. Inspect frame area terminals, clamps, cables, and hold-downs for corrosion.</p> <p>a. See that a gun assembly is on each of the discharge hoses. Check that the gun handle operates the valve. Close the valves.</p> <p>b. Inspect the gun assembly and slurry nozzle assembly for dirt and hardened slurry. Inspect the threaded fittings for nicks, burrs, or other damage. Inspect the gun handle for cracks, chips, twists, bends, or other damage that would interfere with efficient operation. Inspect the extension pipe and adapter for cracks, bends, holes, being out of round, or other damage that would affect operation of the gun assembly.</p> <p>c. Clean the hardened slurry or dirt from the gun and slurry nozzle assembly. Be especially careful to clean the hard-to-reach areas around the gun handle and the adapter threads.</p> <p>(1) Thoroughly clean all nozzles that have been used to spray liquids other than water.</p> <p>(2) Use soapy water and a small brush to loosen the dirt. Rinse with clean water, and dry all parts thoroughly.</p> <p>(3) Inspect the gasket for cuts, wear, and deformation.</p>	<p>Electrolyte level is low.</p> <p>Gun valves inoperative.</p> <p>Nozzle is clogged.</p>

Table 2-2. OPERATOR'S PREVENTIVE MAINTENANCE CHECKS AND SERVICES (PMCS) (CONT)

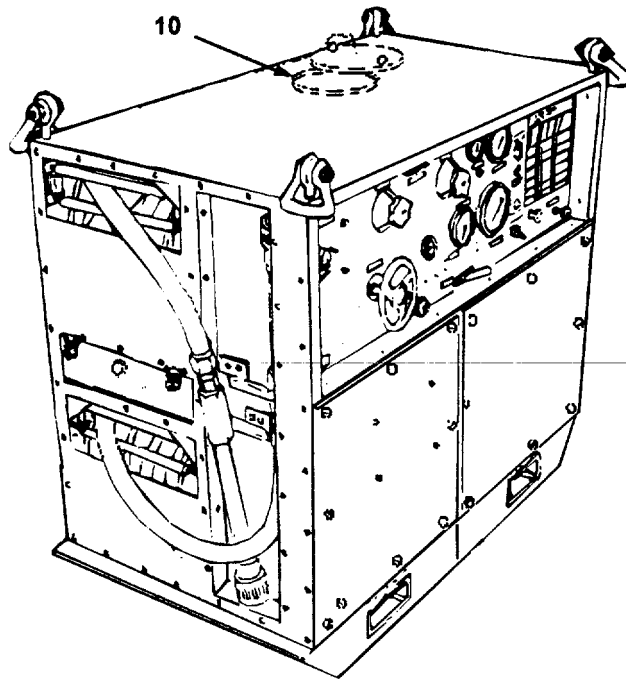

Item No.	Interval	Location, Item to Check/Service	Procedure	Not Fully Mission Capable If:
10	Pump Unit Assembly (Cont) BEFORE QUARTERLY QUARTERLY	Prime-Detergent Tank Assembly and Tank Lid	a. Check that there are no foreign objects or sediment in tank. Clean if necessary. Close VALVE NO. 4 PRIME on control panel. Fill tank with water and check for leaks. b. See that the tank is fastened to the pump unit. See that the tank lid is in place. c. Inspect tank lid for cracks and for loose, missing and corroded parts.	Foreign objects or sediment are in tank. Tank leaks continuously.

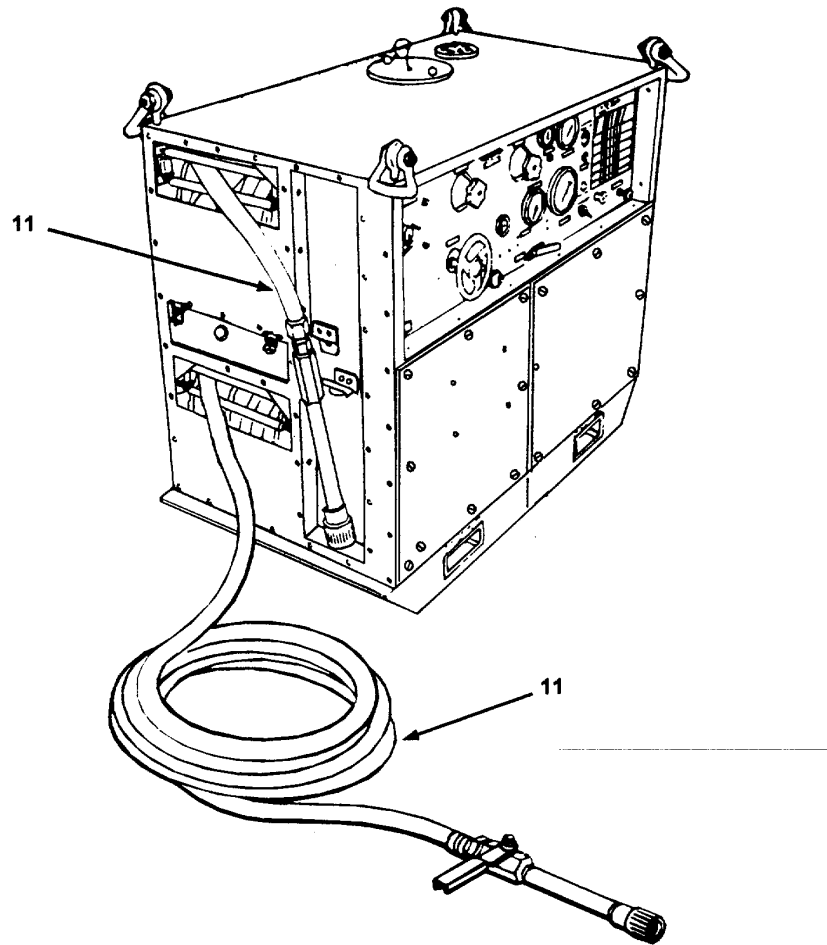

Item No.	Interval	Location, Item to Check/Service	Procedure	Not Fully Mission Capable If:
11	BEFORE, DURING and QUARTERLY QUARTERLY	Discharge Hose Assemblies	a. Inspect discharge hoses for leaks, breaks, or other damage. b. Flush hoses with hot water. Wash exterior of discharge hoses with hot, soapy water. Dry all parts thoroughly. Clean metal parts with a cloth (item 22, app D) dampened with dry cleaning solvent (item 10, app D), if required.	Discharge hose leaks continuously.

Table 2-2. OPERATOR'S PREVENTIVE MAINTENANCE CHECKS AND SERVICES (PMCS) (CONT)

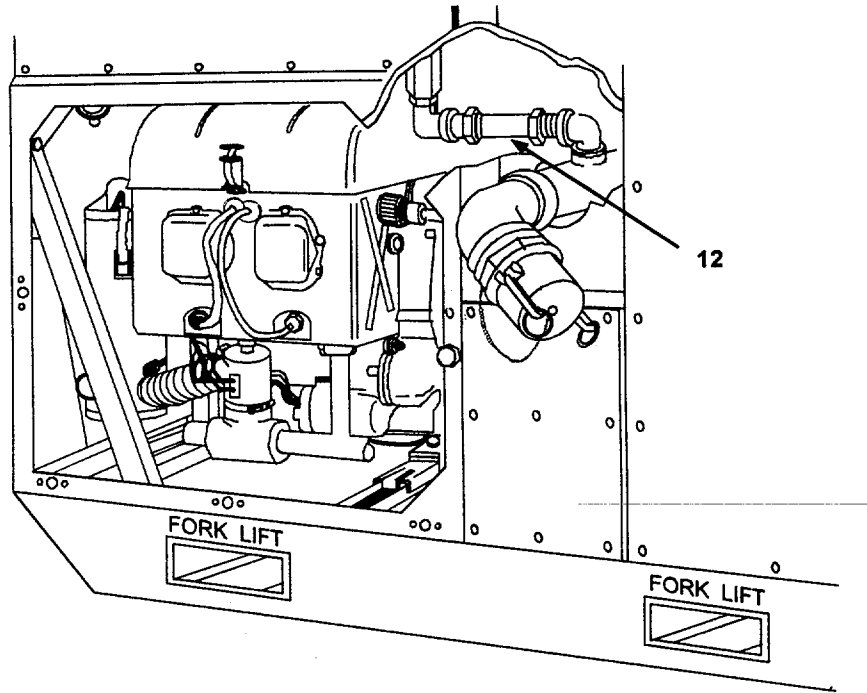

Item No.	Interval	Location, Item to Check/Service	Procedure	Not Fully Mission Capable If:
12	BEFORE and QUARTERLY BEFORE and QUARTERLY	Pump Unit Assembly (Cont) Eductor Hose Assembly	a. Inspect the eductor hose for leaks or breaks. b. Make sure hose clamps are tight.	Eductor hose leaks.

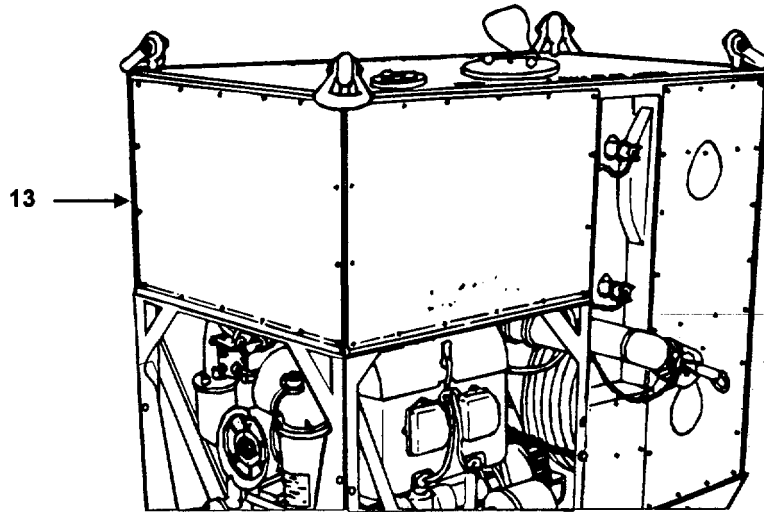

Item No.	Interval	Location, Item to Check/Service	Procedure	Not Fully Mission Capable If:
13	BEFORE	Fuel Tank	<p><u>WARNING</u></p> <p>Inspect fuel tank interior in daylight. If the fuel tank must be inspected at night, use a vapor-proof light.</p> <p>a. Remove fuel tank cap (1). Lift out strainer (2) with screen. Clean screen. See that there are no foreign objects or sediment in tank. Replace strainer (2) with screen.</p>	Foreign objects or sediment are in tank.

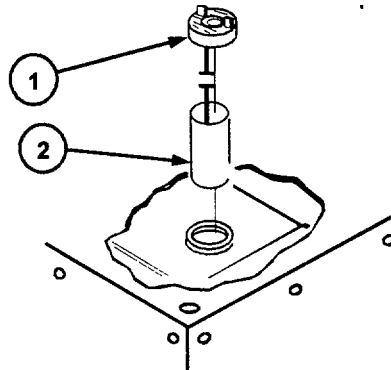
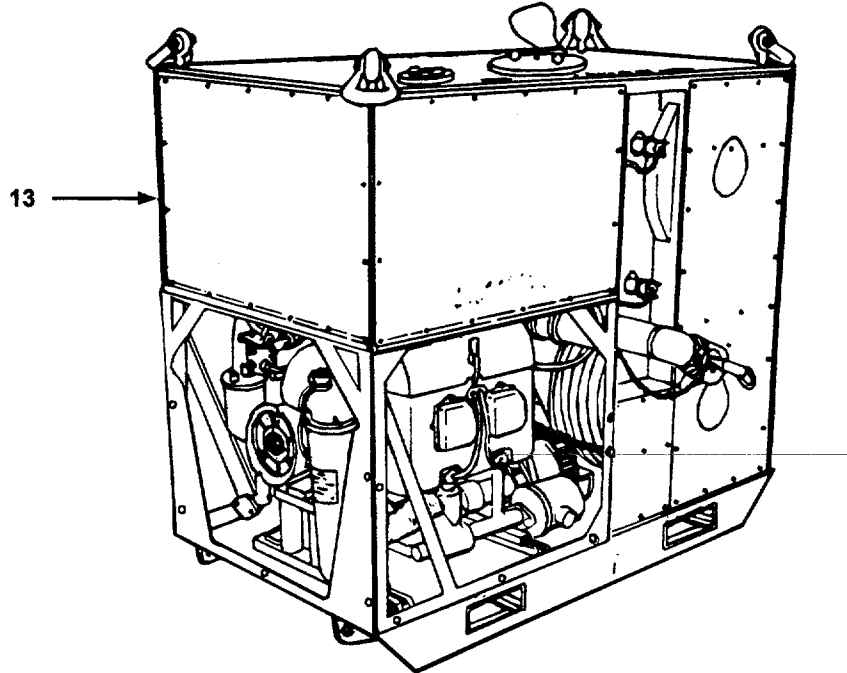

Table 2-2. OPERATOR'S PREVENTIVE MAINTENANCE CHECKS AND SERVICES (PMCS) (CONT)



Item No.	Interval	Location, Item to Check/Service	Procedure	Not Fully Mission Capable If:
13	BEFORE QUARTERLY	Pump Unit Assembly (Cont) Fuel Tank (Cont)	b. Fill fuel tank with gasoline and check for leaks. c. Check that fuel tank is tightly mounted to pump unit.	Fuel tank leaks.

Item No.	Interval	Location, Item to Check/Service	Procedure	Not Fully Mission Capable If:
	BEFORE		<p>d. Check that fuel filter is clean and does not leak.</p> <ol style="list-style-type: none"> (1) Tighten FUEL SHUT OFF valve (3) to shut off fuel line. Close finger nut (4) at top of sediment bowl (8). (2) Loosen thumbscrew (5) on fuel filter (6), swing bail (7) to one side, and remove sediment bowl (8). (3) Remove deposits from sediment bowl (8) and clean filter. (4) Inspect gasket (9). (5) Set sediment bowl (8) with gasket filter in bail (7) and tighten thumbscrew (5). Open finger nut at top of sediment bowl. Loosen FUEL SHUT OFF valve to allow fuel to go through fuel filter (6). Make sure sediment bowl (8) does not leak. <p>e. Check that FUEL SHUT OFF valve and fuel hoses do not leak. Tighten hose clamp if necessary.</p>	<p>Fuel filter is dirty or leaks.</p> <p>Gasket is missing.</p> <p>Sediment bowl leaks.</p> <p>Fuel shutoff valve or fuel hoses leak.</p>
	BEFORE			

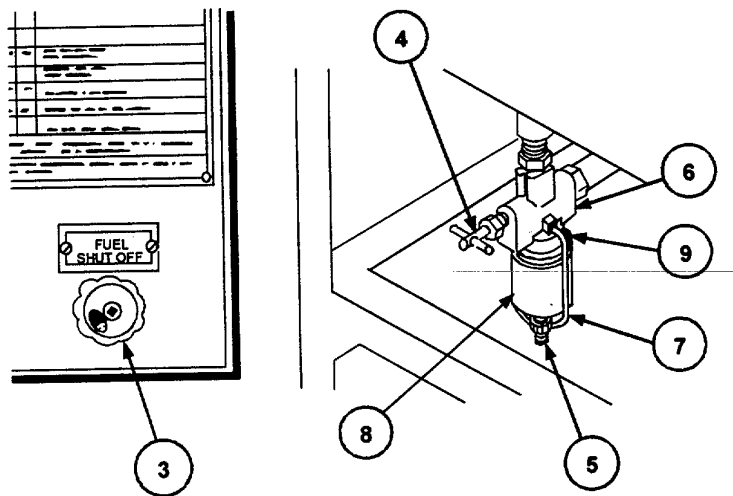
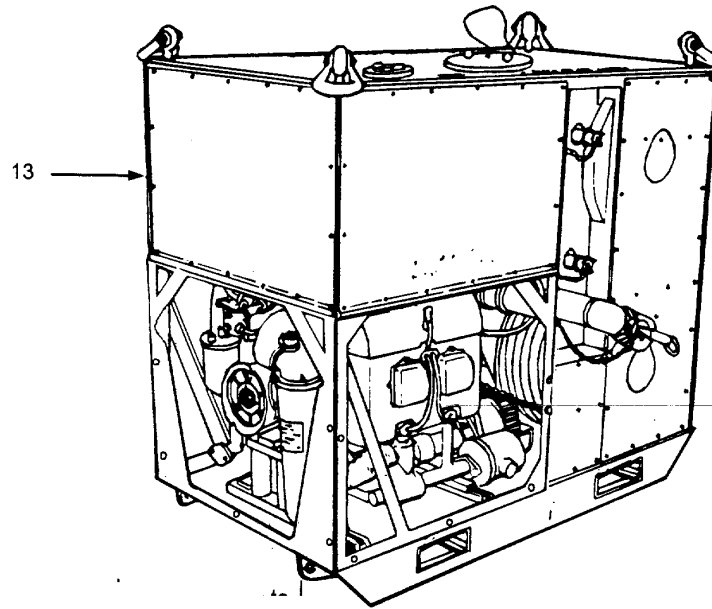
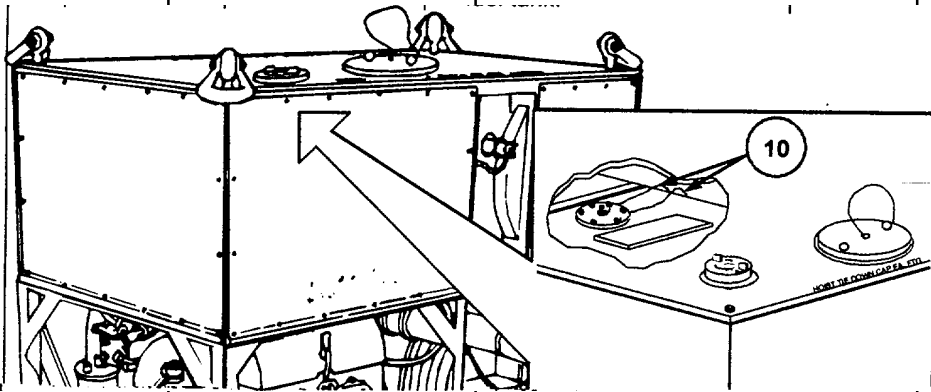

Table 2-2. OPERATOR'S PREVENTIVE MAINTENANCE CHECKS AND SERVICES (PMCS) (CONT)



Item No.	Interval	Location, Item to Check/Service	Procedure	Not Fully Mission Capable If:
13	BEFORE	Pump Unit Assembly (Cont) Fuel Tank (Cont)	f. Check that fuel level transmitter electrical wires (10) are fastened to their respective terminals on top of fuel tank.	
	BEFORE		g. Check that fuel tank is filled with gasoline.	Tank is empty.



Item No.	Interval	Location, Item to Check/Service	Procedure	Not Fully Mission Capable If:
	BEFORE and DURING		<p>h. Check that fuel quantity gage registers when FUEL INDICATOR switch is pressed.</p> <hr/>  <p>The diagram shows two gauges. On the left is a fuel indicator with markings for 'E' (Empty) and 'F' (Full), and a needle pointing to the '1/2' mark. Below it is a rectangular label 'FUEL INDICATOR' with two terminals. On the right is a vacuum gage with a scale from 0 to 15 and a needle pointing to '0'. Below it is a rectangular label 'VACUUM GAGE' with two terminals.</p>	
	QUARTERLY		<p>WARNING Fire and explosion danger exist when dry cleaning solvent (SD) is used. Make sure that equipment is dry before operations begin. Fuel must be removed from fuel tank before using wire brush.</p> <p>i. Clean outside of tank with dry cleaning solvent (item 10, app D). Dry thoroughly.</p> <p>j. Remove any rust and corrosion from outside of tank using a wire brush (item 5, app D).</p> <p>k. Repaint outside of tank or fuel cap (item 21, app D) as necessary. Highlight fuel cap lettering with yellow paint (item 11, app D) as necessary.</p>	
	QUARTERLY			
	QUARTERLY			

Table 2-2. OPERATOR'S PREVENTIVE MAINTENANCE CHECKS AND SERVICES (PMCS) (CONT)



Item No.	Interval	Location, Item to Check/Service	Procedure	Not Fully Mission Capable If:
14	<p>QUARTERLY</p> <p>BEFORE and QUARTERLY</p> <p>QUARTERLY</p>	<p>Pump Unit Assembly (Cont)</p> <p>Pump Unit Subassembly</p>	<p>a. Check that washers, nuts, and bolts are securely in place.</p> <p>b. Check that centrifugal pump support is not broken, cracked, or dented.</p> <p>WARNING Fire and explosion danger exist when dry cleaning solvent (SD) is used. Make sure that equipment is dry before operations begin.</p> <p>c. Clean pump unit subassembly with dry cleaning solvent (item 10, app D). Dry thoroughly. Remove any rust and corrosion with a wire brush (item 5, app D). Repaint (item 21, app D) as necessary.</p>	<p>Centrifugal pump supports broken or missing.</p>

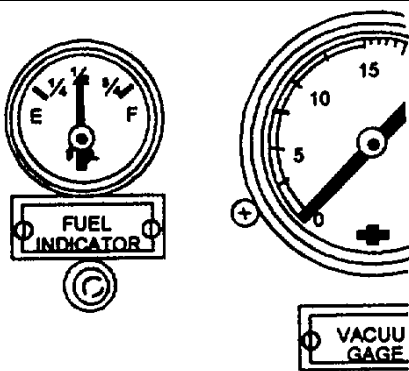
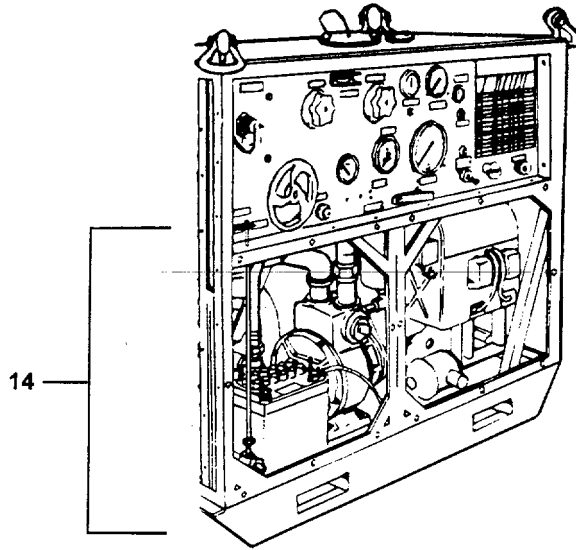
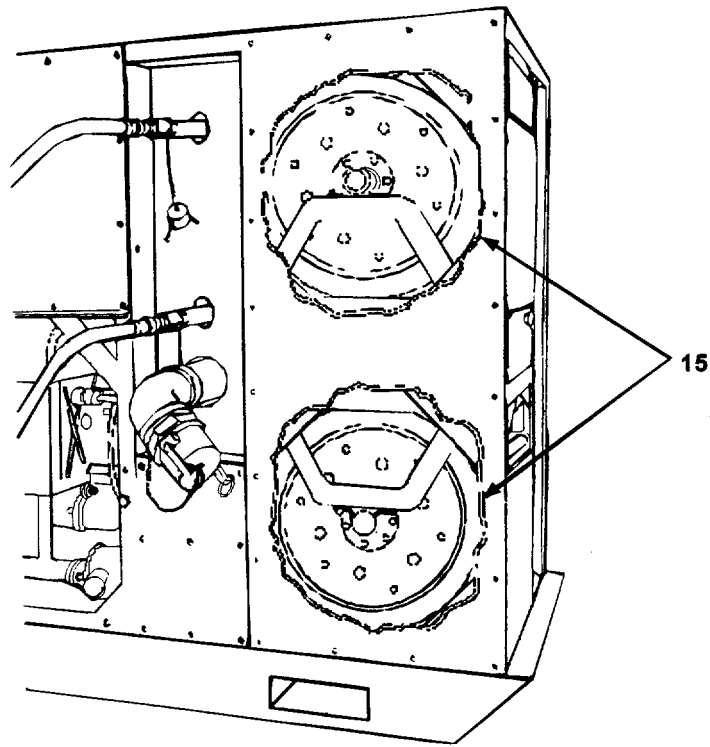

Item No.	Interval	Location, Item to Check/Service	Procedure	Not Fully Mission Capable If:
15	BEFORE QUARTERLY QUARTERLY	Hose Reels	a. Inspect that the crank handles insert easily and they turn the reels smoothly. b. Inspect that the two lubrication fittings on the swivel pipes are clean and not broken. c. Remove any rust with wire brush (item 5, app D) and repaint with paint (item 21, app D).	

Table 2-2. OPERATOR'S PREVENTIVE MAINTENANCE CHECKS AND SERVICES (PMCS) (CONT)

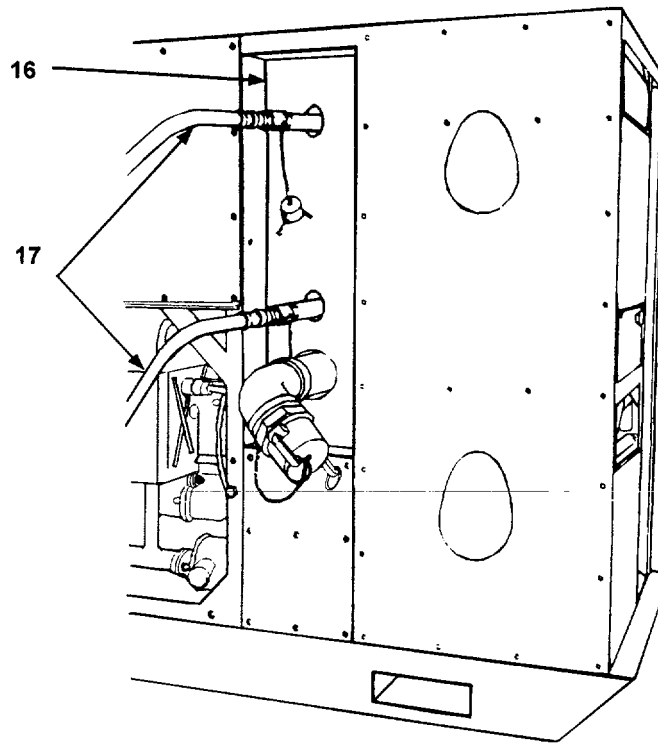

Item No.	Interval	Location, Item to Check/Service	Procedure	Not Fully Mission Capable If:
16	QUARTERLY	Pump Unit Assembly (Cont)	a. Inspect that the chains connected to the dust caps are in good condition and are securely fastened. b. Check that the dust caps each have a seal installed inside the cap. c. Clean connector panel with hot soapy water and rinse with clear water.	Seal is missing.
	BEFORE	Connector Panel		
	QUARTERLY			
17	DURING	Outlet Hoses	Check hoses and couplings for leaks.	Hoses and couplings leak continuously.

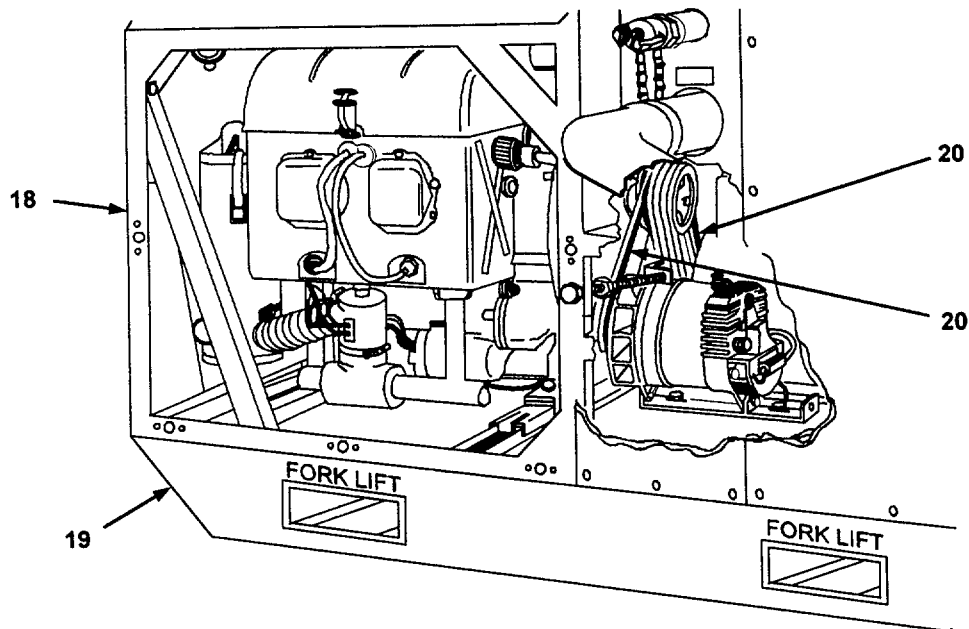

Item No.	Interval	Location, Item to Check/Service	Procedure	Not Fully Mission Capable If:
18	QUARTERLY QUARTERLY QUARTERLY	Frame Assembly	<ul style="list-style-type: none"> a. Inspect for missing hardware or parts. b. Inspect for broken welds or dents. c. Wash with hot soapy water. Rinse with clear water. Remove any rust and corrosion with a wire brush (item 5, app D). Repaint (item 21, app D) as necessary. 	
19	QUARTERLY	Skid Base Subassembly	Inspect for rust, corrosion, welds, dents, or loose hardware.	
20	BEFORE	Drive Belts	Check pump and alternator/generator drive belts for wear, breaks, or fraying. Check for proper tension: 5-7 lbs at 3/8-inch deflection. Adjust if necessary (para 3-7).	One or more belts broken or missing. Tension incorrect and no adjustment remaining.

Table 2-2. OPERATOR'S PREVENTIVE MAINTENANCE CHECKS AND SERVICES (PMCS) (CONT)

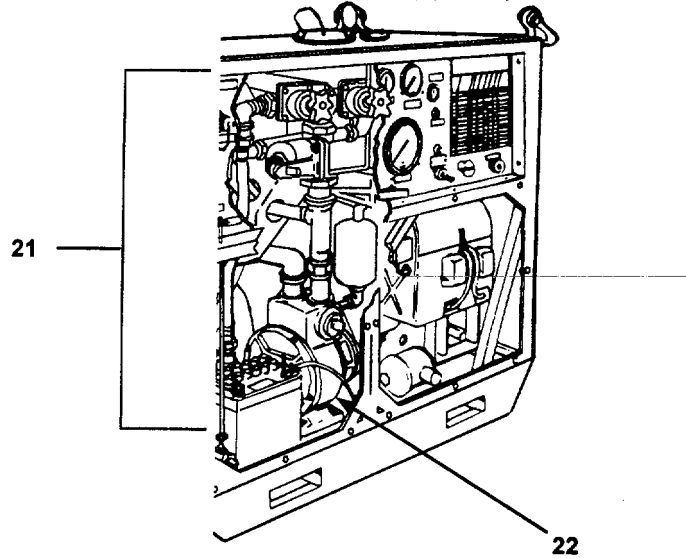

Item No.	Interval	Location, Item to Check/Service	Procedure	Not Fully Mission Capable If:
21	<p>BEFORE and QUARTERLY BEFORE and DURING BEFORE</p> <p>QUARTERLY</p>	<p>Pump Unit Subassembly Plumbing Assembly</p>	<p>a. Lubricate pump in accordance with LO 3-4230-209-10.</p> <p>b. Inspect piping for cracks, corrosion, and evidence of leaks.</p> <p>c. Check the four valves for smooth operation and leakage.</p> <p>WARNING Fire and explosion danger exist when dry cleaning solvent (SD) is used. Make sure that equipment is dry before operations begin.</p> <p>d. Clean with dry cleaning solvent (item 10, app D); dry thoroughly. Remove rust and corrosion with a wire brush (item 5, app D). Repaint as necessary (item 21, app D).</p>	<p>Piping leaks continuously.</p>

Item No.	Interval	Location, Item to Check/Service	Procedure	Not Fully Mission Capable If:
22	<p>BEFORE and DURING BEFORE and DURING</p> <p>QUARTERLY</p>	<p>Centrifugal Pump</p> 	<p>a. Inspect the pump housing for cracks, corrosion, and leaks.</p> <p>b. Check that the pump is tightly mounted to the skid base and that all piping connections do not leak.</p> <p>c. Inspect that lube fitting (1) and breather (2) are not broken or missing.</p>	<p>Pump housing leaks continuously. Piping connections leak continuously, and pump is not mounted tightly.</p>
	<p>BEFORE and QUARTERLY</p>		<p>d. Lubricate in accordance with LO 3-4230-209-10.</p> <p>WARNING Fire and explosion danger exist when dry cleaning solvent (SD) is used. Make sure that equipment is dry before operations begin.</p>	
	<p>QUARTERLY</p>		<p>e. Wash outside of pump with dry cleaning solvent (item 10, app D). Dry thoroughly. Remove rust and corrosion with a wire brush (item 5, app D). Repaint (item 21, app D) as necessary.</p>	

Table 2-2. OPERATOR'S PREVENTIVE MAINTENANCE CHECKS AND SERVICES (PMCS) (CONT)



Item No.	Interval	Location, Item to Check/Service	Procedure	Not Fully Mission Capable If:
23	<p>BEFORE and QUARTERLY</p> <p>BEFORE and QUARTERLY QUARTERLY</p>	<p>Pump Unit Subassembly (Cont) VALVE NO. 1 MANIFOLD</p>	<p>a. Check that mounting hardware is tight. Inspect valve and associated piping for leaks, or rust. Turn valve handle and check that valve turns smoothly and easily.</p> <p>b. Lubricate valve stem in accordance with LO 3-4230-209-10.</p> <p>c. Remove any rust or corrosion with wire brush (item 5, app D). Repaint (item 21, app D) as required. Wash with hot soapy water and rinse with clean water.</p>	<p>Valve does not open or close completely, or valve leaks continuously.</p>

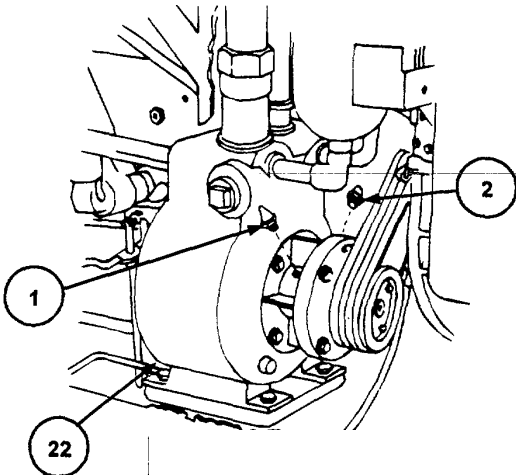
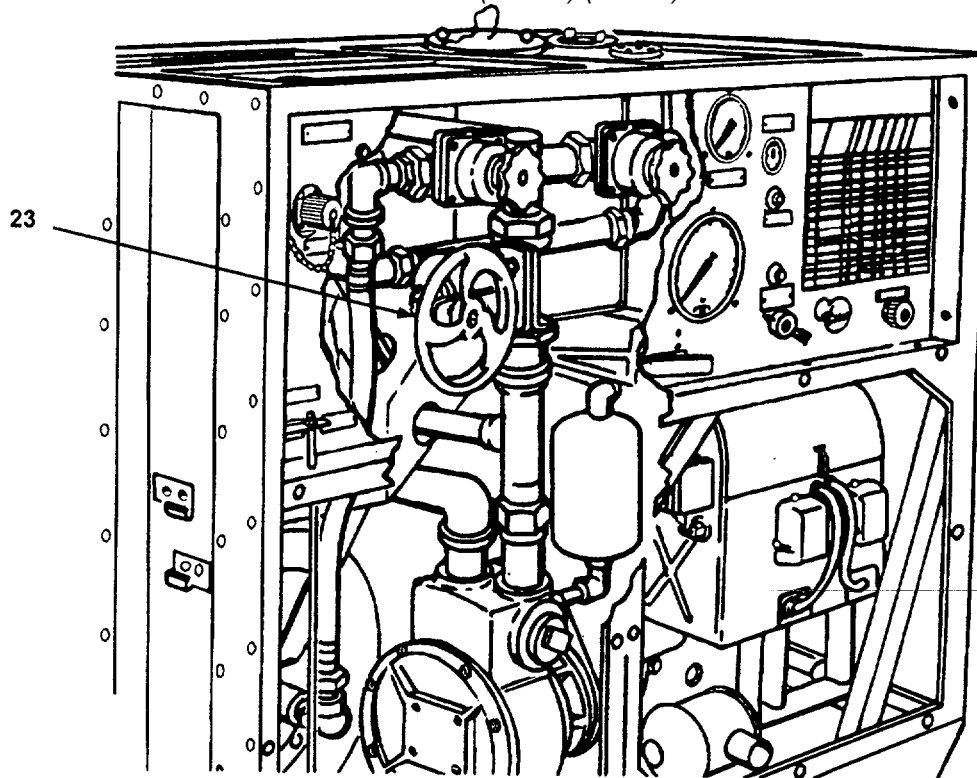
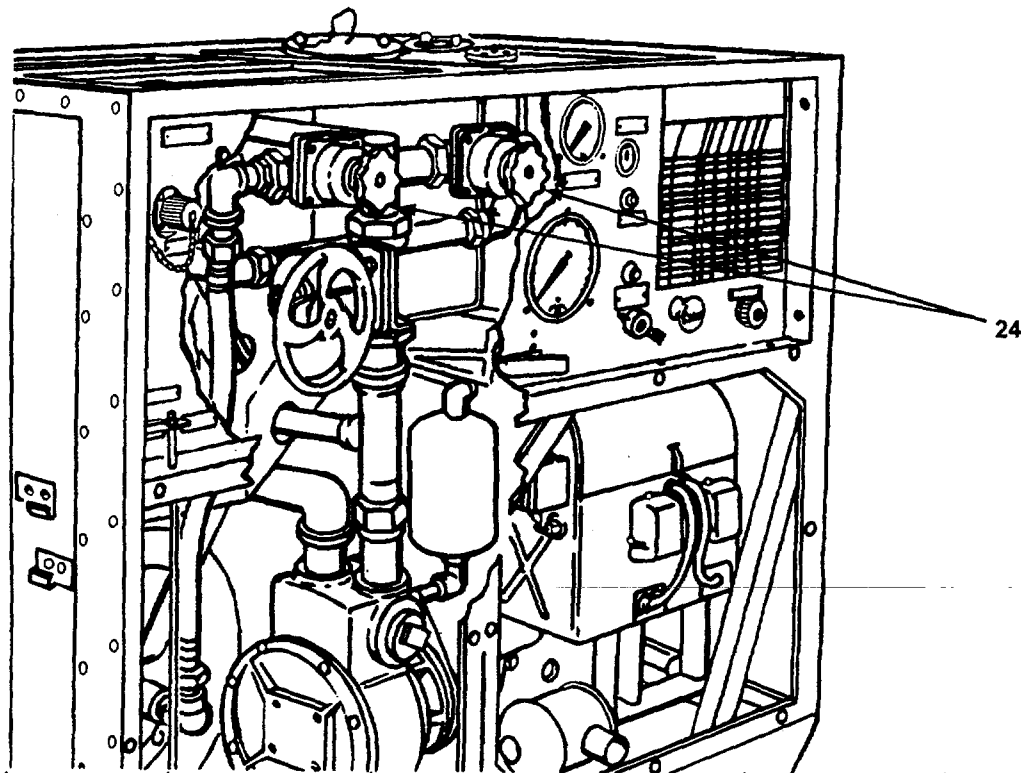

Item No.	Interval	Location, Item to Check/Service	Procedure	Not Fully Mission Capable If:
24	<p>BEFORE and QUARTERLY</p> <p>BEFORE and QUARTERLY</p> <p>BEFORE and DURING</p> <p>QUARTERLY</p>	<p>VALVE NO. 2 LOWER REEL and VALVE NO. 3 UPPER REEL</p>	<p>a. Check that the valves turn smoothly completely.</p> <p>b. Lubricate valve stems in accordance with LO 3-4230-209-10.</p> <p>c. Inspect the valves for evidence of leaks, corrosion, or breaks.</p> <p>WARNING Fire and explosion danger exist when dry cleaning solvent (SD) is used. Make sure that equipment is dry before operations begin.</p> <p>d. Clean regulating valves with dry cleaning solvent (item 10, app D) and dry.</p>	<p>Valve does not open or close</p> <p>Valves leak continuously.</p>

Table 2-2. OPERATOR'S PREVENTIVE MAINTENANCE CHECKS AND SERVICES (PMCS) (CONT)

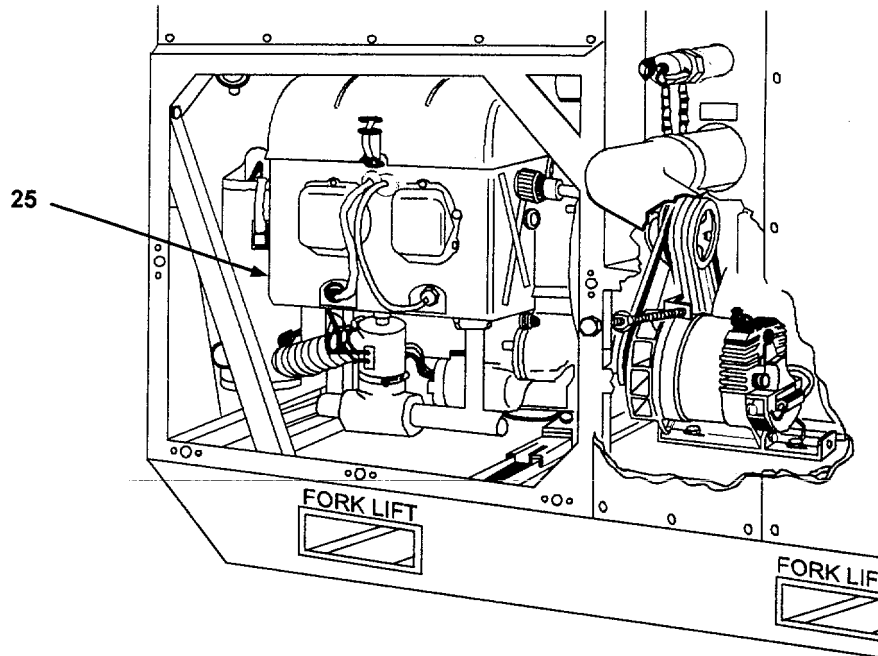

Item No.	Interval	Location, Item to Check/Service	Procedure	Not Fully Mission Capable If:
25	<p>BEFORE</p> <p>BEFORE</p>	20 HP Gasoline Engine Assembly	<p>CAUTION</p> <p>Do not operate engine if shrouds have been removed or are not securely fastened. See TM 9-2805-259-14.</p> <ol style="list-style-type: none"> a. Check that engine shrouds are installed and locked in place. b. Make sure that vibration shock pads are present and in good condition. 	Shock pads are missing.

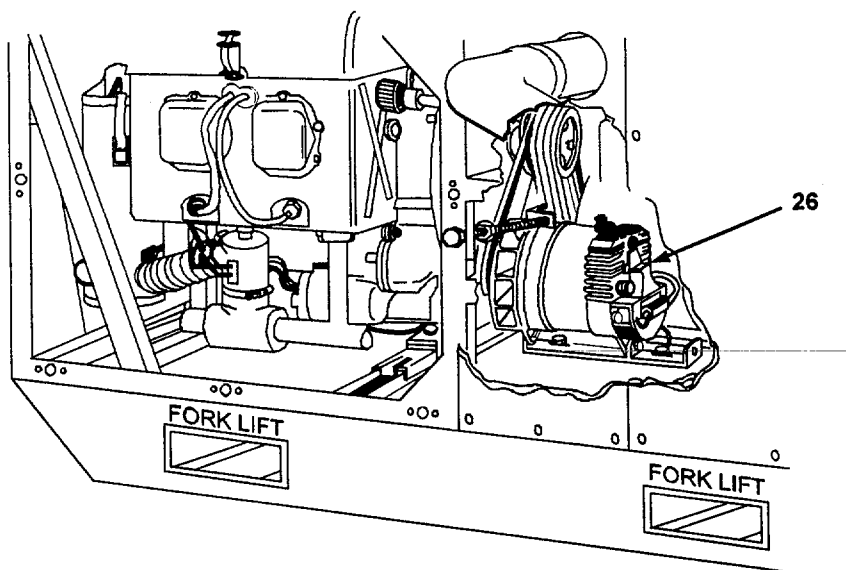

Item No.	Interval	Location, Item to Check/Service	Procedure	Not Fully Mission Capable If:
26	<p>BEFORE and QUARTERLY</p> <p>BEFORE</p> <p>BEFORE and QUARTERLY</p> <p>QUARTERLY</p>	Alternator/Generator Assembly	<p>a. See that no parts are missing and that hardware fastening the assembly to the base is not loose or missing.</p> <p>b. Check that the electrical cables are fastened at both terminals.</p> <p>c. Check that pulley is not bent or cracked.</p> <p style="text-align: center;"><u>WARNING</u></p> <p>Fire and explosion danger exist when dry cleaning solvent (SD) is used. Make sure that equipment is dry before operations begin.</p> <p>d. Clean exterior of alternator/generator with cloth dampened with dry cleaning solvent (item 10, app D). Dry thoroughly. Clean V-belt groove of pulley with a cloth dampened with dry cleaning solvent (item 10, app D). Dry thoroughly. Remove any rust and corrosion with a wire brush (item 5, app D).</p>	<p>Resistor is missing.</p> <p>Cables are damaged or missing. Pulley is bent or cracked.</p>

Table 2-2. OPERATOR'S PREVENTIVE MAINTENANCE CHECKS AND SERVICES (PMCS) (CONT)

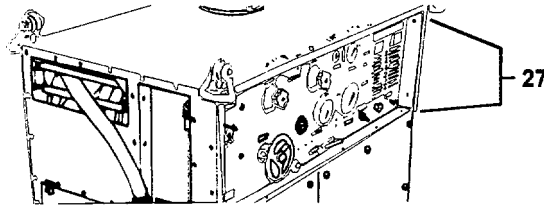

Item No.	Interval	Location, Item to Check/Service	Procedure	Not Fully Mission Capable If:
27	DURING	Pump Unit Assembly (Cont) Control Panel Assembly	<p>a. The control panel can be inspected without having to remove it from the pump unit assembly. Wipe all switches and gages with cloth to remove accumulated dirt. Clean the control panel with a cloth (item 22, app D) and water. Inspect switches for loose parts or damaged leads. Inspect gages for cracked dials.</p> <p style="text-align: center;">CAUTION</p> <p>Do not operate pump dry or when discharge pressure is below 60 psi. If more time is needed to correct fault, shut down.</p>	PRESSURE GAGE, VACUUM GAGE, or oil pressure gage are not working.
	DURING		<p>b. Check that gages and TACHOMETER work and read correctly: VACUUM GAGE: 0-30 inches of mercury, Water PRESSURE GAGE: 60-120 psi, Oil Pressure Gage: greater than 20 psi, FUEL INDICATOR Gage: above empty, TACHOMETER: 3850 rpm or less.</p>	
	BEFORE		<p>c. Inspect that HEATER RECEPTACLE AND SWITCH hardware securely fasten the SWITCH to the control panel.</p>	

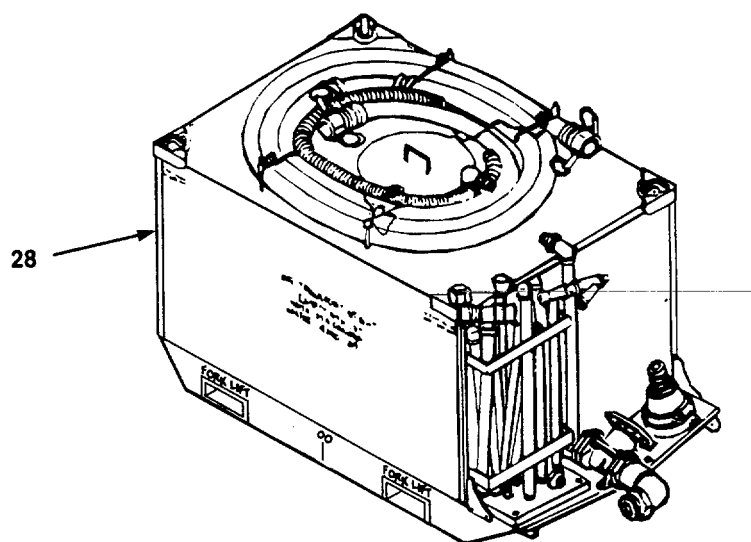

Item No.	Interval	Location, Item to Check/Service	Procedure	Not Fully Mission Capable If:
28	<p>BEFORE and QUARTERLY</p> <p>BEFORE, AFTER, and QUARTERLY</p> <p>BEFORE and QUARTERLY</p> <p>QUARTERLY</p> <p>AFTER and QUARTERLY</p> <p>QUARTERLY</p>	Tank Unit	<p>a. Check that tank is fastened to skid base assembly.</p> <p>b. Check that suction hose, and exhaust pipe extensions are stowed properly on top of the tank unit.</p> <p>c. Inspect for broken welds, leaks, obstructions, loose pipe fittings, and missing parts.</p> <p>d. Check that the markings and identification plates for the drain, agitator, and blender connectors are legible and firmly fastened.</p> <p>e. Inspect the tank interior to see that it is clean and no slurry has accumulated or hardened on the tank walls.</p> <p>f. Clean tank with hot, soapy water. Remove any slurry which may have accumulated using brush (item 5, app D). Rinse with clear water. Remove rust and corrosion with wire brush (item 5, app D). Repaint as necessary (item 21, app D).</p>	Tank leaks continuously.

Table 2-2. OPERATOR'S PREVENTIVE MAINTENANCE CHECKS AND SERVICES (PMCS) (CONT)

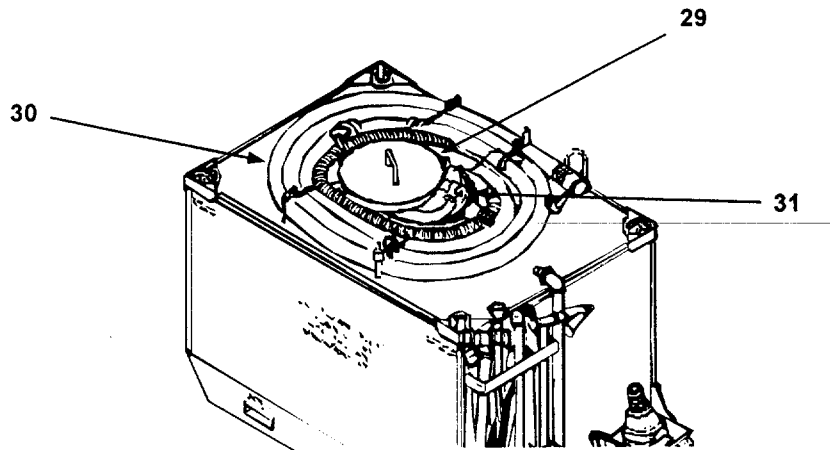

Item No.	Interval	Location, Item to Check/Service	Procedure	Not Fully Mission Capable If:
29	BEFORE and QUARTERLY BEFORE and QUARTERLY BEFORE, AFTER, and QUARTERLY QUARTERLY	Tank Unit (Cont) Hopper Assembly	<ul style="list-style-type: none"> a. Inspect the hopper assembly for broken welds and evidence of leaks. b. Check that fitting is not out of round or loose. c. Check that dry slurry has not accumulated on inside screen. d. Check that chains fasten the bolts to the bracket clamp. e. Check that the blender hose is coiled inside the hopper when not in use. 	<p>Fitting is out of round or loose.</p> <p>Screen is completely blocked.</p>
30	BEFORE, AFTER, and QUARTERLY DURING and QUARTERLY BEFORE and QUARTERLY DURING	Suction Hose Assembly	<ul style="list-style-type: none"> a. Inspect the suction hose assembly for leaks or breaks. b. Check that quick release couplings have gaskets installed. 	<p>Hose leaks continuously.</p> <p>Gaskets are missing.</p>
31	DURING and QUARTERLY BEFORE and QUARTERLY	Blender Hose	<ul style="list-style-type: none"> a. Inspect the blender hose assembly for leaks or breaks. b. Check that quick release couplings have gaskets installed. 	<p>Hose leaks continuously.</p> <p>Gaskets are missing.</p>

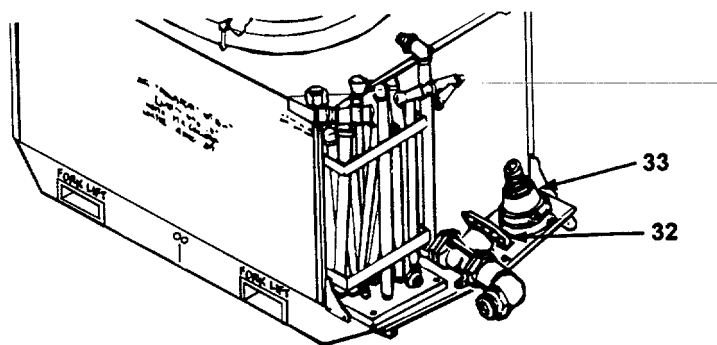

Item No.	Interval	Location, Item to Check/Service	Procedure	Not Fully Mission Capable If:
32	<p>BEFORE and QUARTERLY</p> <p>BEFORE and QUARTERLY</p> <p>BEFORE, DURING and QUARTERLY</p> <p>BEFORE and QUARTERLY</p> <p>QUARTERLY</p>	Tank Drain Valve	<p>WARNING</p> <p>When operating regulating valve, be careful not to catch fingers in slot.</p> <p>a. Check that the tank drain valve turns smoothly and that stem has been lubricated.</p> <p>b. Lubricate in accordance with LO 3-4230-209-10.</p> <p>c. Inspect the tank drain valve for evidence of leaks, corrosion, or breaks.</p> <p>d. Check that all mounting hardware is tight and secure.</p> <p>e. Wash with hot, soapy water, then rinse with clear water. Remove rust and slurry deposits with a wire brush (item 5, app D). Repaint as needed (item 21, app D).</p>	Drain valve does not turn or open and close completely.
33	<p>BEFORE and QUARTERLY</p> <p>BEFORE and QUARTERLY</p> <p>AFTER and QUARTERLY</p>	Foot Valve	<p>a. Check the foot valve for missing parts.</p> <p>b. Check for breaks or cracks.</p> <p>c. Make sure that the valve is securely mounted to the skid base.</p>	Parts are missing.

Table 2-2. OPERATOR'S PREVENTIVE MAINTENANCE CHECKS AND SERVICES (PMCS) (CONT)

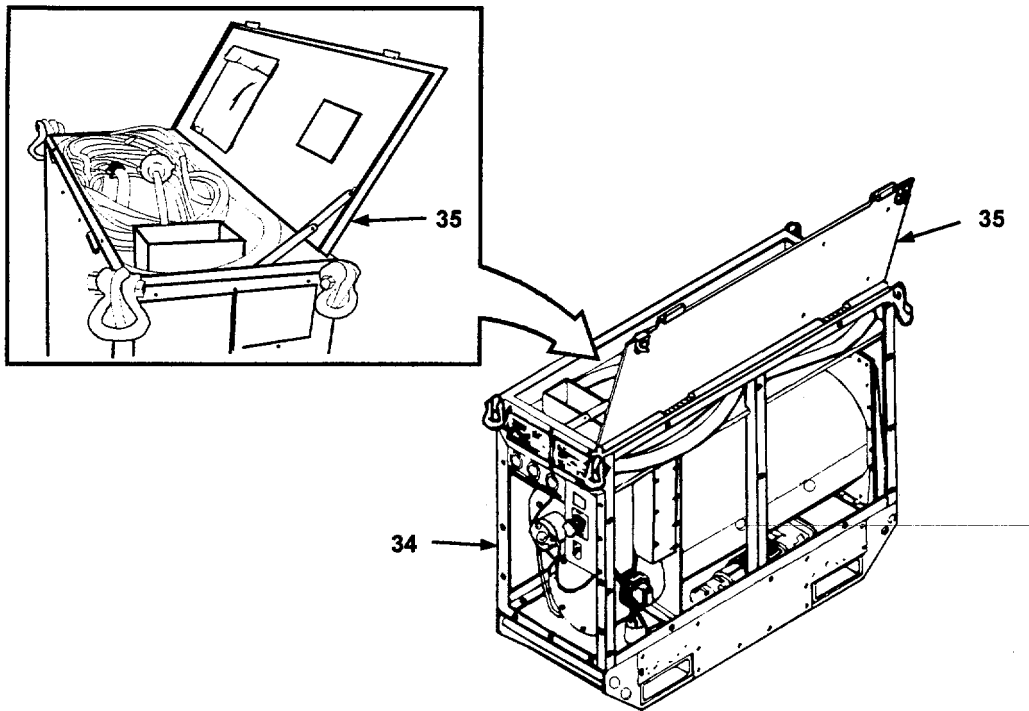

Item No.	Interval	Location, Item to Check/Service	Procedure	Not Fully Mission Capable If:
34	<p>BEFORE, AFTER, and QUARTERLY</p> <p>BEFORE and QUARTERLY</p> <p>BEFORE and QUARTERLY</p> <p>DURING</p>	Water Heater	<p>a. Inspect to see that all cables and hoses are properly stored in storage compartment.</p> <p>b. Inspect for loose or missing nuts or bolts. Tighten hardware when necessary.</p> <p>c. Check that all decals, stencils, and identification plates are legible.</p> <p>d. While the water heater is operating, inspect for evidence of steam leaks around the refractory gasket between the firebox and the end of the boiler.</p>	<p>Identification plates are missing.</p> <p>Steam is leaking.</p>

Item No.	Interval	Location, Item to Check/Service	Not Fully Mission Procedure Capable If:	
35	BEFORE and QUARTERLY	Water Heater (Cont)	e. Check that electrical wiring is not touching boiler.	Electrical wire is touching boiler.
	QUARTERLY		<p style="text-align: center;"><u>WARNING</u></p> Fire and explosion danger exist when dry cleaning solvent (SD) is used. Make sure that equipment is dry before operations begin.	
	QUARTERLY	Cabinet Top Cover	f. Clean with dry cleaning solvent (item 10, app D) and dry thoroughly. Remove rust and foreign material with wire brush (item 5, app D). Repaint if necessary (item 21, app D).	
	QUARTERLY		a. Inspect the cover for loose, missing, bent, rusted, dirty, corroded, or worn parts.	
	QUARTERLY		b. Check that the cover is not bent and that the painted surfaces are in good condition.	
	QUARTERLY		c. Inspect the tool carrier for rips or tears.	
	QUARTERLY		<p style="text-align: center;"><u>WARNING</u></p> Fire and explosion danger exist when dry cleaning solvent (SD) is used. Make sure that equipment is dry before operations begin.	
			d. Clean lid and tools with dry cleaning solvent (item 10, app D) and dry thoroughly. Wash the tool carrier canvas cover with water and detergent (item 8, app D) and dry thoroughly. Remove rust and corrosion with a wire brush (item 5, app D). Repaint (item 21, app D) as necessary.	

Table 2-2. OPERATOR'S PREVENTIVE MAINTENANCE CHECKS AND SERVICES (PMCS) (CONT)

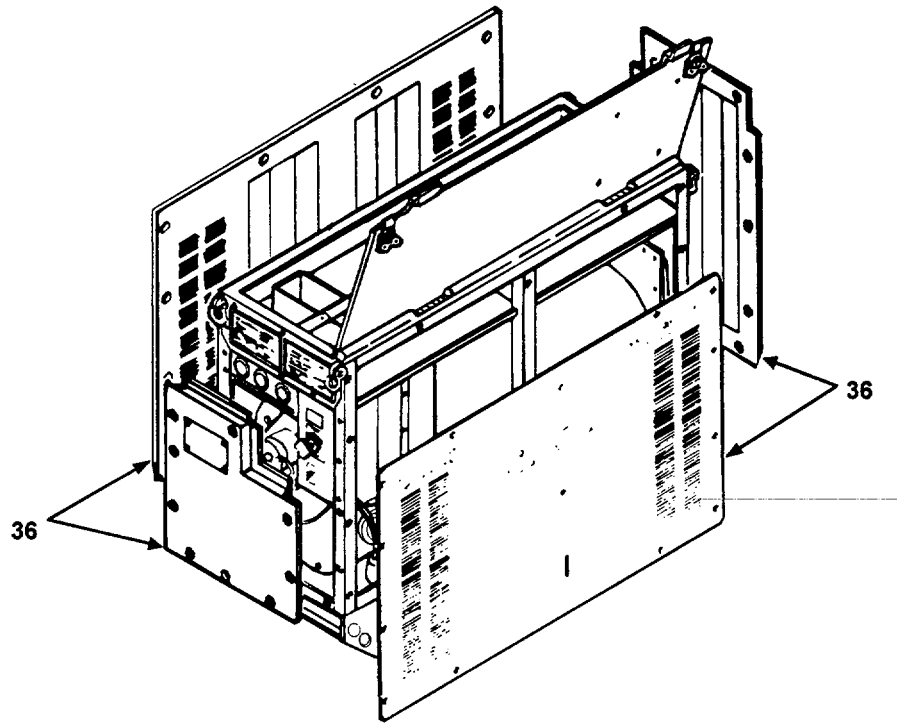

Item No.	Interval	Location, Item to Check/Service	Procedure	Not Fully Mission Capable If:
36	QUARTERLY QUARTERLY QUARTERLY QUARTERLY QUARTERLY	Water Heater (Cont) Cover Panels	a. Inspect panels for loose or missing parts. b. Inspect for dented or bent panels. c. Inspect condition of turnlock fastener stud assemblies. d. Wash panels with hot, soapy water. Rinse with clear water. Remove rust or corrosion with a wire brush (item 5, app D). Repaint as necessary (item 21, app D). e. Replace excessively blackened or loose heat reflective tape (item 27, app D) in the same location as original tape.	

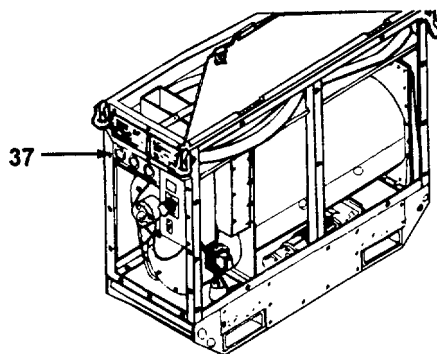

Item No.	Interval	Location, Item to Check/Service	Procedure	Not Fully Mission Capable If:
37	<p>BEFORE and QUARTERLY BEFORE, AFTER and QUARTERLY BEFORE</p> <p>DURING</p> <p>QUARTERLY</p>	<p>Water Heater (Cont) Control Box Assembly</p>	<p>a. Inspect control box for broken, missing, or loose parts. Tighten as necessary.</p> <p>b. Inspect to see that the glass in the fuel, water, and temperature gages is not broken.</p> <p>c. Check that controls and instruments are in good condition. Set heater control switch to PURGE ON. See that gages work and are reading correctly: WATER PRESSURE Gage: 60-120 psi. FUEL PRESSURE Gage: at startup only, 60-75 psi, depending on fuel type. During operation may be lower or higher. WATER TEMPERATURE Gage: 40F - 190°F.</p> <p>d. Wash front panel and gage faces with hot, soapy water. Rinse with clear water. Remove rust and corrosion with a wire brush (item 5, app D). Repaint as necessary (item 21, app D).</p>	<p>WATER PRESSURE gage is not working.</p> <p>FUEL PRESSURE gage not working.</p> <p>WATER TEMPERA-TURE gage not working.</p>

Table 2-2. OPERATOR'S PREVENTIVE MAINTENANCE CHECKS AND SERVICES (PMCS) (CONT)

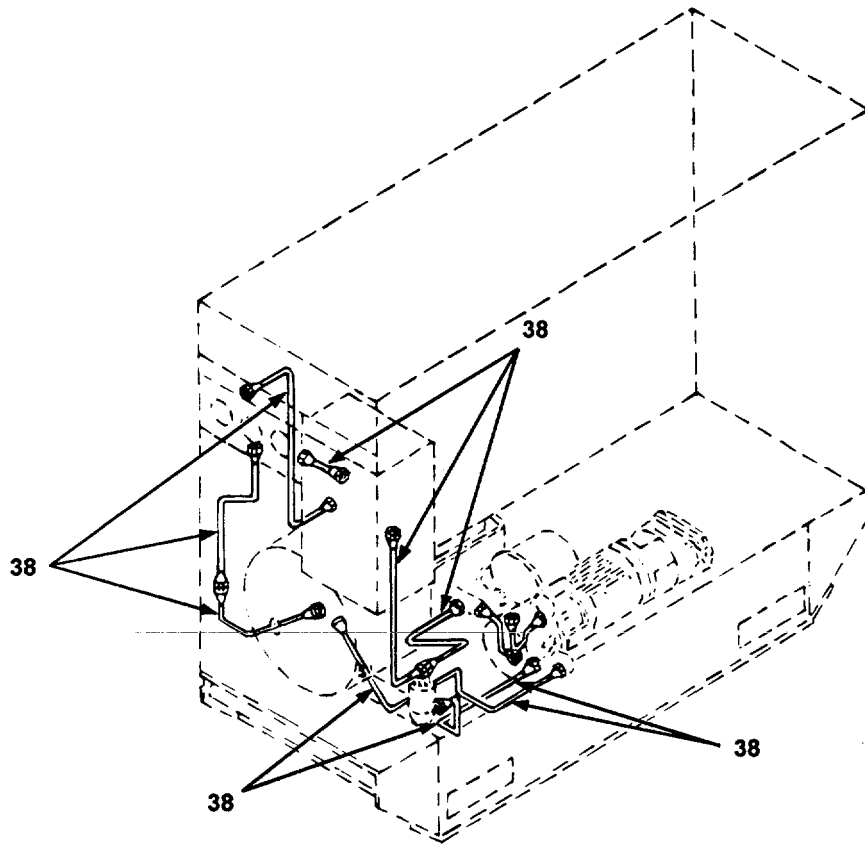

Item No.	Interval	Location, Item to Check/Service	Procedure	Not Fully Mission Capable If:
38	BEFORE and QUARTERLY . DURING	Water Heater (Cont) All Fabricated Lines	a. Check all the fabricated lines for signs of kinks and sharp bends. b. Check to see that pressure lines are not leaking.	Lines are kinked. Fuel lines leak.

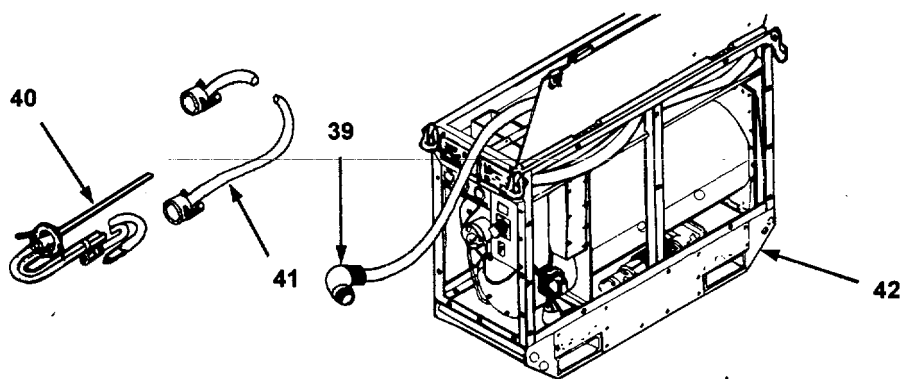

Item No.	Interval	Location, Item to Check/Service	Procedure	Not Fully Mission Capable If:
39	BEFORE and QUARTERLY	Power Cable	Check for cracks, deterioration, bare or frayed wire and kinks.	Badly worn cable.
40	BEFORE and QUARTERLY BEFORE QUARTERLY DURING	Fuel Hose Assembly	a. Check for cuts or breaks. Check fuel hose connectors for ease of operation. b. Check that connectors are clean and free of foreign matter. c. Check that rubber gasket is present on fuel can adapter. d. Check for major leaks from hoses and connectors.	Unworkable plug connector. Unserviceable hose or connectors. Rubber gasket is missing. Hoses or connectors leak.
41	BEFORE BEFORE and QUARTERLY DURING	Water Hose	a. Check that all connections are tight. b. Inspect for cracks and broken or missing parts. c. Inspect for leaks.	Water hose leaks continuously. Gaskets are missing.
42	BEFORE and QUARTERLY	Skid Assembly	a. Inspect all skid assembly components for breaks, cracks, or dents. b. Inspect to see if any wires are loose or disconnected.	Wires are disconnected.

Table 2-2. OPERATOR'S PREVENTIVE MAINTENANCE CHECKS AND SERVICES (PMCS) (CONT)

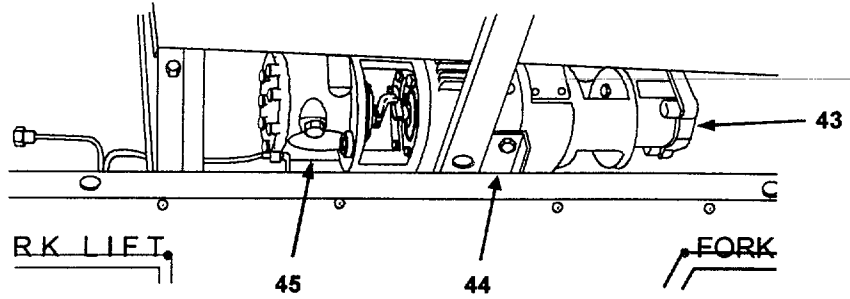

Item No.	Interval	Location, Item to Check/Service	Procedure	Not Fully Mission Capable If:
43	<p>BEFORE and QUARTERLY BEFORE and QUARTERLY BEFORE and QUARTERLY</p> <p>QUARTERLY</p>	<p>Water Heater (Cont) Magneto Assembly</p>	<p>a. Check that mounting hardware is present and tight. Tighten as necessary.</p> <p>b. Check that drive arm is in place and is not broken.</p> <p>c. See that the magneto turns freely with a flick of a finger.</p> <p>WARNING Fire and explosion danger exist when dry cleaning solvent (SD) is used. Make sure that equipment is dry before operations begin.</p> <p>d. Wipe with a clean cloth (item 22, app D) dampened with dry cleaning solvent (item 10, app D). Dry thoroughly. Remove any rust and corrosion with wire brush (item 5, app D). Repaint (item 21, app D) as necessary.</p>	<p>Spring pin is missing. Drive arm is broken. Magneto does not move.</p>
44	<p>BEFORE and QUARTERLY BEFORE and QUARTERLY</p>	<p>Fuel Pump and Ignition Drive Motor</p>	<p>a. See that all mounting hardware is present and secure.</p> <p>b. Check that drive arms are in place and not broken.</p>	<p>Drive arms are broken or missing.</p>

Item No.	Interval	Location, Item to Check/Service	Procedure	Not Fully Mission Capable If:
45	<p>QUARTERLY</p> <p>DURING</p> <p>DURING</p> <p>QUARTERLY</p>	Fuel Pump	<p><u>WARNING</u></p> <p>Fire and explosion danger exist when dry cleaning solvent (SD) is used. Make sure that equipment is dry before operations begin.</p> <p>c. Wipe with a clean cloth (item 22, app D) dampened with dry cleaning solvent (item 10, app D). Dry thoroughly. Remove any rust or corrosion with a wire brush (item 5, app D).</p> <p>a. Check for leaks from pump, piping, and hose connections while operating in PURGE ON.</p> <p>b. Check for correct pressure for type of fuel used.</p> <p>c. Check that drive arms are in place and not broken. missing.</p>	<p>Any leaks are present. (Because of extreme hazard of fuel vapors, the water heater must not be operated until the leak has been corrected.) Pressure wrong or low for fuel used. Drive arms are broken or</p>

Table 2-2. OPERATOR'S PREVENTIVE MAINTENANCE CHECKS AND SERVICES (PMCS) (CONT)

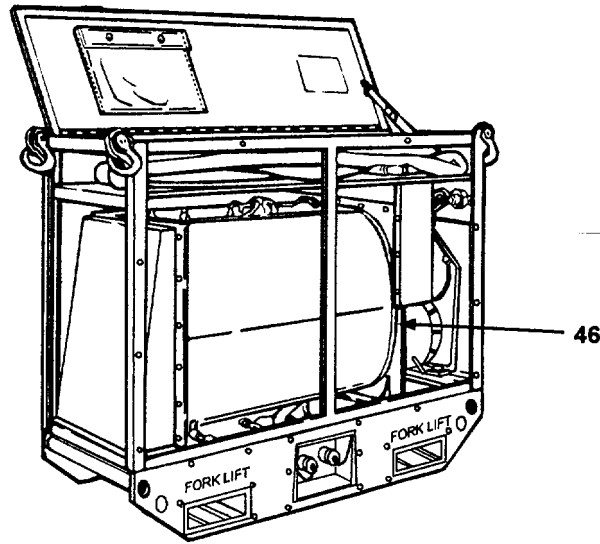

Item No.	Interval	Location, Item to Check/Service	Procedure	Not Fully Mission Capable If:
46	<p>DURING</p> <p>DURING and QUARTERLY</p> <p>BEFORE and QUARTERLY</p> <p>QUARTERLY</p>	<p>Water Heater (Cont)</p> <p>Low Pressure Boiler Assembly</p>	<p>a. Be sure that the boiler is completely full of water and that the water is circulating before firing the boiler.</p> <p>b. Inspect for leaks and loose or missing parts, especially around the refractory box end of the boiler.</p> <p>c. Check to see that the exhaust stack screen is not broken, loose, missing, or full of soot.</p> <p>d. Clean all exposed surfaces with hot soapy water. Rinse with clear water. Do not allow water to enter exhaust stack. Remove rust and corrosion with a wire brush (item 5, app D). Remove soot and foreign matter from spark arrester screen using a wire brush (item 5, app D). Touch up surfaces with paint (item 21, app D) as required.</p>	<p>Boiler is not full of water.</p> <p>Screen is broken or missing.</p>

Section III. OPERATION UNDER USUAL CONDITIONS

WARNING

Wear protective clothing and a mask when engaged in decontaminating operations. STB decontaminating agent (item 7, app D) and slurry are harmful to the skin, eyes, lungs, and clothing. If STB decontaminating agent or slurry gets into the eyes, flush them immediately with clear water. If STB decontaminating agent or slurry is taken internally, drink raw egg white, milk, rice gruel or milk of magnesia. Do not induce vomiting and seek medical assistance immediately. If STB decontaminating agent or slurry contacts the skin, wash off immediately with clear water.

2-4. SCOPE. This section contains instructions for operating the decontaminating apparatus under normal conditions of climate and service. Normal conditions are considered to be operation in warm weather + 50° F (+ 10° C) and above.

2-5. PERSONNEL. Five men will be assigned to operate an M12A1 decontaminating apparatus. Each decontaminating section has a section chief, a decontaminating equipment operator, a decontaminating equipment helper, and two spray man-loaders.

2-6. CHEMICAL PROTECTIVE CLOTHING. All operating personnel will wear protective clothing and mask when performing decontamination operations. Different types of chemical protective clothing are available for wear in different weather conditions and for special purposes. Permeable clothing allows the passage of air and moisture through the fabric; impermeable clothing does not. Combat troops normally will be issued Standard-A permeable clothing. TM 10-277 describes and illustrates how various items of chemical protective clothing are worn.

2-7. FUELING.

WARNING

Do not allow smoking when filling the fuel tank with gasoline. Also do not permit open flame, sparks, or heated objects in the area.

Authorized fuel will be obtained only from authorized fuel services or fuel trucks. Siphoning fuel from vehicles is prohibited. Siphoning can cause static electricity, mouth and throat damage, and lead poisoning.

CAUTION

When filling the tank with fuel, be sure the dispenser hose nozzle on the container is clean and that the nozzle on the container contacts the filler neck on the sleeve to conduct static electricity away. Do not overfill the fuel tank. Room for expansion must be provided.

2-7. FUELING (CONT).

1

- a. Wipe off the dirt around the filler pipe opening and the fuel tank cap. Remove the cap by turning it counterclockwise until it stops. Then press down, to allow the projections on the cap pressure plate to pass under the projections on the filler pipe neck ramp, and lift off the cap.
- b. Fill the fuel tank until the fuel is approximately one inch below the filler neck.

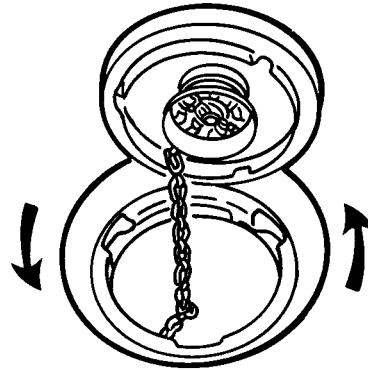

WARNING

Running the M12A1 with the vent closed causes a vacuum inside the fuel tank. That can cause the engine to stop running. Removing the fuel tank cap too fast could let in-rushing air force fuel out of the tank. If the gas spills on the engine, the M12A1 could catch fire and explode, causing injury to personnel. The fuel tank cap vent stays open.

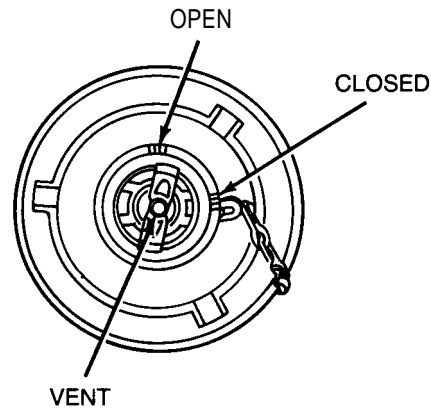

2

Make sure that the vent inside the cap is open and push the filler sleeve down. Place the cap on the filler neck and turn it clockwise until a stop is felt, Press down on the cap and turn farther to lock it.

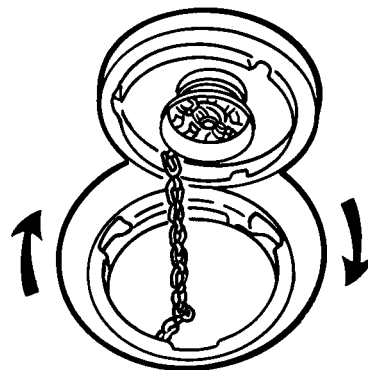

2-8. LOADING SUPPLIES AND PROTECTIVE CLOTHING Load supplies in the quantities needed on the vehicle or trailer being used to transport the decontaminating apparatus. See that protective clothing for the crew performing decontaminating operations is available and ready to use. (See appendix D for expendable/durable supplies and refer to TM 10-277 for protective clothing.)

2-9. INITIAL ADJUSTMENTS, DAILY CHECKS, AND SELF TESTS Perform BEFORE preventive maintenance checks and services (PMCS), table 2-2, items 1 through 46.

2-10. PREPARATION FOR OPERATION Perform the BEFORE PMCS procedures in table 2-2, items 1 through 46.

WARNING

The gasoline engine and water heater exhausts are lethal. Do not inhale these gases. A chemical-biological mask does not protect against carbon monoxide. When the decontaminating apparatus is to be operated, the exhaust gases must be vented away from the operator and outside of an enclosed area to prevent carbon monoxide poisoning. To avoid injury or electrical shock, keep the HEATER RECEPTACLE AND SWITCH on the pump unit control panel to OFF when the water heater is not in use.

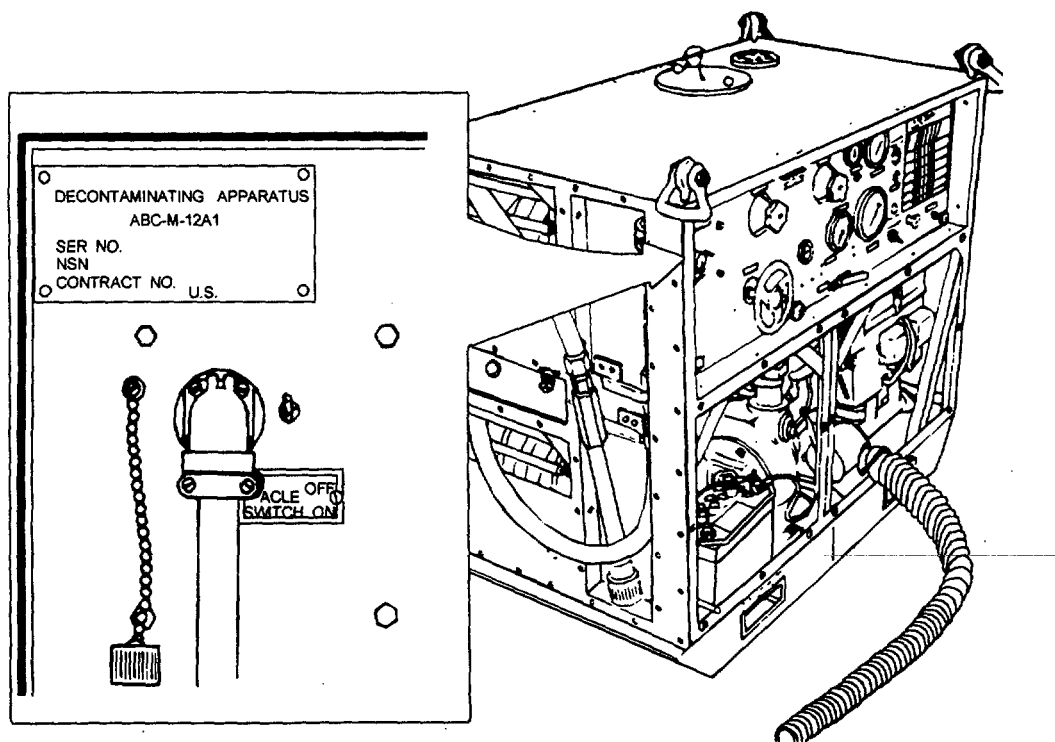

2-11. STARTING THE PUMP UNIT.

1

STARTING PROCEDURE

CAUTION: Do not operate pump dry or when discharge pressure is below 40 p.s.i.g. Reduce engine speed to idle before turning off ignition. READ THE MANUAL

1. Check all valve settings before starting.
2. Open throttle about one-half to start.
3. Turn starting switch to start, and at the same time, depress oil pressure switch.
4. When engine starts, release start switch to run position but continue depressing oil pressure switch until oil pressure exceeds 20 p.s.i.g.; then release oil pressure switch.
5. Adjust throttle to 3150 R.P.M. (Tachometer reading)
6. Check all gages to insure proper operation.
7. Prime-Detergent Valve #4 must be closed when Prime-Detergent Tank is empty.

VALVE POSITION
O—OPEN X—CLOSED

OPERATION NO	OPERATION	PREVIOUS OPERATION REQUIRED	SUCTION HOSE TO DISCHARGE TANK	DISCHARGE CONNECTION UPPER	DISCHARGE CONNECTION LOWER	VALVE #1	MANIFOLD	VALVE #2	LOWER REEL	VALVE #3	UPPER REEL	VALVE #4	PRIME DETERGENT	REMARKS
1	PRIME DRY PUMP TURN ON FUEL SUPPLY START (SEE PROCEDURE)	—	S	ON	CAP	O	X	X	O				**	*TO TANK AGITATOR CONNECT ONE INCH HOSE **OPEN FOR 1 MINUTE BEFORE STARTING, THEN CLOSE TO HALFWAY FOR REMAINDER OF PRIME OPERATION (SEE 7 ABOVE)
2	FILL TANK WITH WATER	1	S	ON	CAP	O	X	X	X					*TO AGITATOR CONNECT ONE INCH HOSE
3	BLEND SLURRY	2	T	ON	CAP	O	X	X	X					*TO TANK BLENDER ADD ANTISEPTIC THEN ADD STB
4	AGITATE SLURRY	3	T	ON	CAP	O	X	X	X					*TO TANK AGITATOR
5	DISCHARGE UPPER REEL	2, 3	T	CAP	CAP	O	X	O	X					
	SLURRY LOWER REEL													
6	DISCHARGE UPPER REEL	1	S	T	CAP	CAP	O	X	O	X				
	WATER LOWER REEL													
7	DISCHARGE UPPER REEL	1	S	T	ON	ON	X	X	O	X				*FROM HEATER
	HOT WATER LOWER REEL													**TO HEATER
8	PUMP WATER ONLY TO HEATER OR OTHER	1	S	T	ON	CAP	O	X	X	X				*TO HEATER OR OTHER
9	DISCHARGE FOAM UPPER REEL	1	S	T	CAP	CAP	O	X	O	O				*ADJUST FOR PROPER BLEND
	OR DETERGENT LOWER REEL													*ADJUST FOR PROPER BLEND
10	FLUSH SYSTEM	1	S	OPEN TANK DRAIN AND FLUSH TANK THOROUGHLY, THEN OPEN PUMP DRAIN AND FLUSH HOSE REELS AND DISCHARGE CONNECTIONS (SEE MANUAL)										
11	SHUTDOWN PROCEDURE	REDUCE ENGINE SPEED TO IDLE, SHUT OFF IGNITION AND FUEL SUPPLY, CAP ALL PIPES AND CLOSE ALL VALVES EXCEPT PUMP DRAIN VALVE.												

NOTE

The procedure listed below is reflected as the starting procedure on the STARTING PROCEDURE instruction plate. This procedure is performed after all connections are made for the specific operation and the pipes not used are capped. See the instruction plate for specific operation and connections.

Make sure hoses are connected properly for the desired mode of operation. Refer to STARTING PROCEDURE instruction plate or following paragraphs for the specific operation required. (The STARTING PROCEDURE instruction plate is on the control panel of the pump unit.)

2

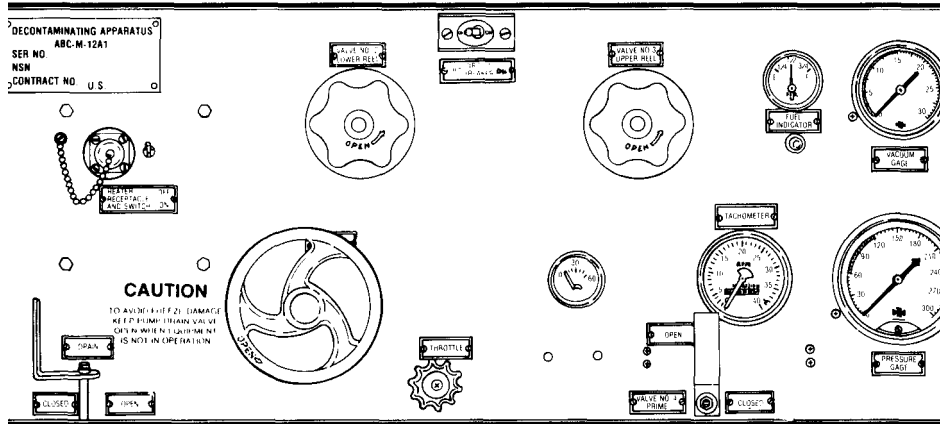

- a. Close the pump DRAIN valve. Using the collapsible canvas pail, fill the prime-detergent tank with water.
- b. Open VALVE NO. 4 PRIME. This allows water from the prime-detergent tank to fill the pump cavity. Make sure water is present in the cavity by opening the pump DRAIN valve briefly. (This valve is in the pump drain piping.) Allow some water to run out. Close the pump DRAIN valve. Remove the cover panels marked REMOVE BEFORE OPERATING on the pump unit.
- c. Open the valves needed for the operation by referring to the STARTING PROCEDURE instruction plate or the following paragraphs for the specific operation required.

NOTE

The THROTTLE has both coarse and fine adjustments. For quick control, press in on the button in the center of the knurled knob and pull out or push in the knob to decrease or increase engine rpm. Rotate the THROTTLE for fine adjustment.

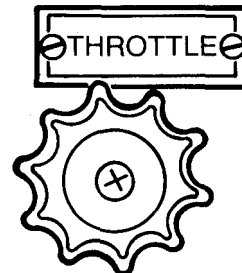

2-11. STARTING THE PUMP UNIT (CONT).

3

Attach the two exhaust pipe extensions (1) stored on top of the tank unit to the two mufflers (2) on either side of the engine. Perform the pump unit check list (table 2-3).

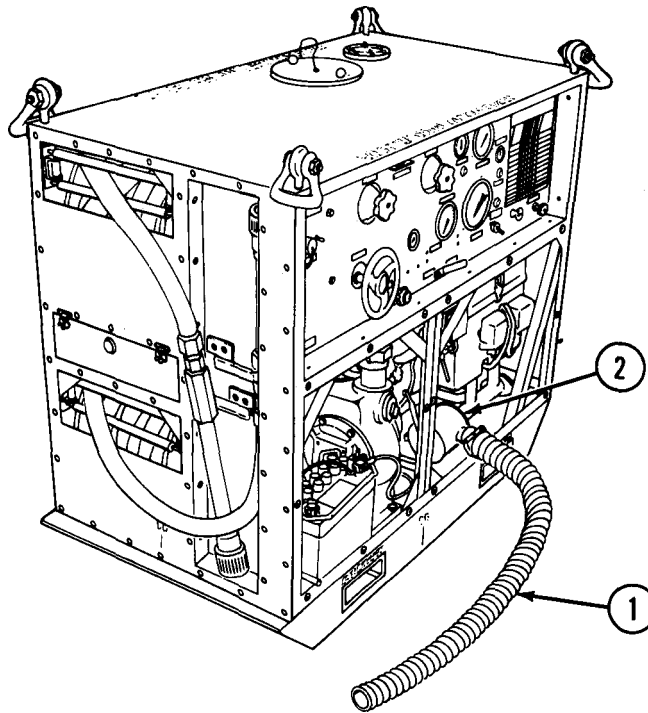
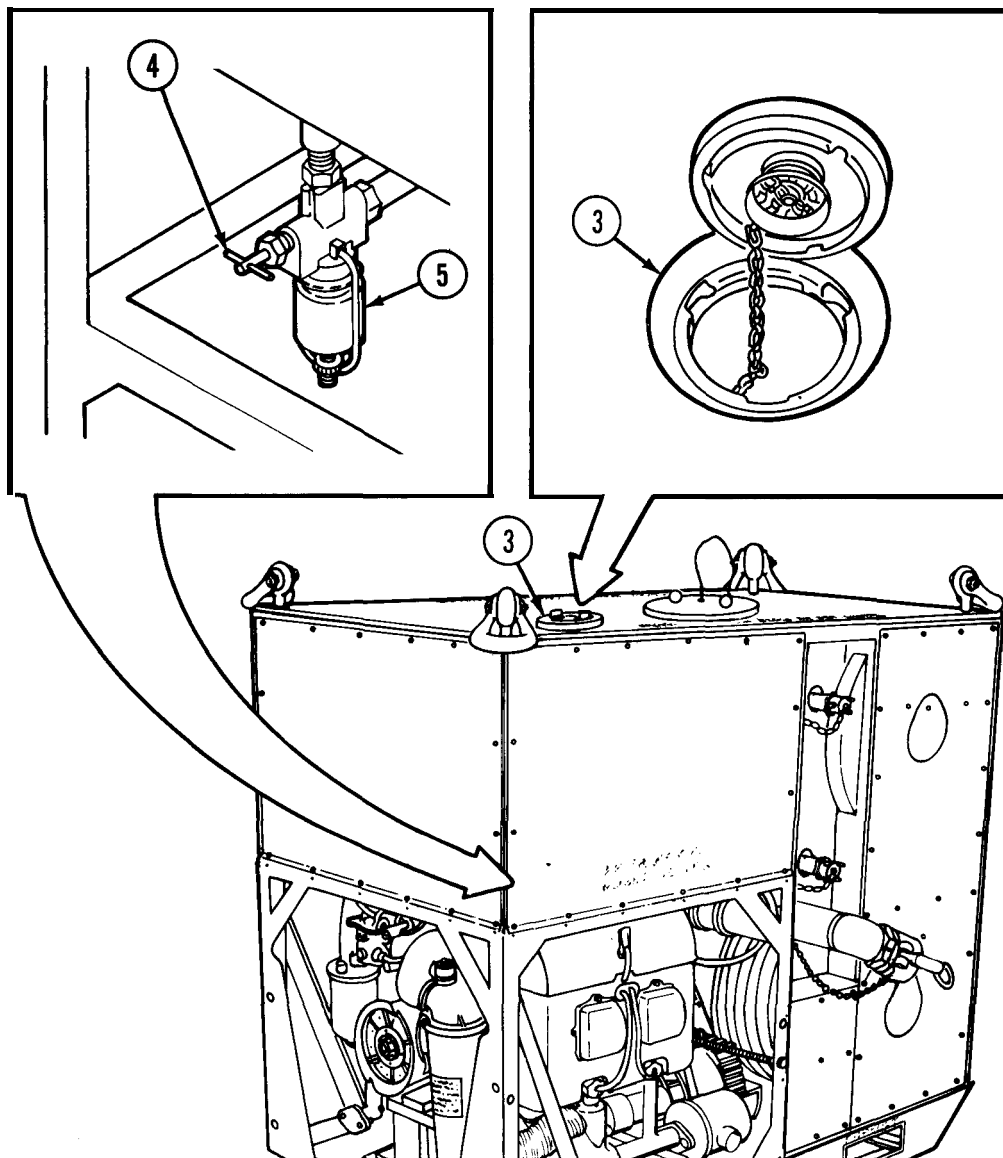

Table 2-3. PUMP UNIT CHECKLIST

Item No.	Item to be Inspected	Procedure
1	Oil level	Pull dipstick from oil fill pipe to check oil level. Add oil, if necessary. Replace dipstick.
2	Prime-detergent tank	Remove tank lid. Check that prime-detergent tank is full of water. Add water, if necessary. Replace tank lid.
3	VALVE NO. 4 PRIME	Check that valve handle is OPEN.
4	Pump DRAIN valve	Bleed air from the pump with the pump DRAIN valve. Then close valve.

Item No.	Item to be Inspected	Procedure
5	Fuel tank	Remove fuel tank cap (3). See that adequate fuel is in fuel tank. Fill with gasoline, if necessary (see fueling, para 2-7). Before replacing cap, ensure that vent is open.



6 Gas

See that the finger nut (4) on the sediment bowl (5) beneath the fuel tank is open. Check that FUEL SHUT OFF valve is open.

2-11. STARTING THE PUMP UNIT (CONT.)

Table 2-3. PUMP UNIT CHECKLIST (CONT)

Item No.	Item to be Inspected	Procedure
7	Manual CHOKE control	Monitor the manual choke. Choke must be operated manually.
8	Air control handle and engine shrouds	<p style="text-align: center;">CAUTION</p> <p>Do not operate engine when shrouds are removed or are not securely fastened.</p> <p>Set air control handle (at bottom of crankcase at rear engine mount) in down position for normal operation. Set air control handle in up position for below 0°F operation. Check that all shrouds are clamped in place to insure the engine is air-cooled.</p>
9	Exhaust pipe extensions	See that both exhaust pipe extensions are connected to the two mufflers on either side of the engine.

4

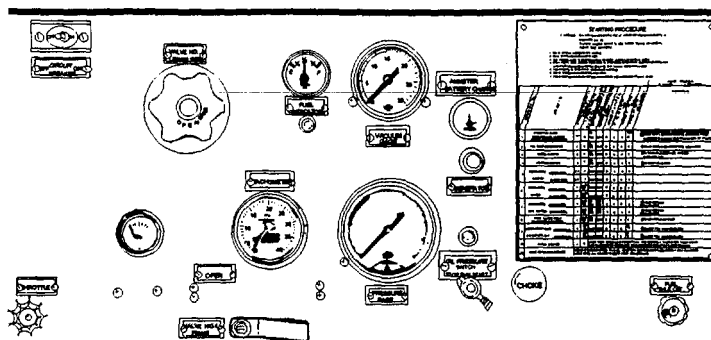
**CAUTION**

If temperature is below 32°F, refer to Operation Under Unusual Conditions. See paragraph 2-27.

Start the engine.

- a. Open the FUEL SHUT OFF valve on the control panel.
- b. Pull the THROTTLE out until it stops and can go no farther. Push the THROTTLE in halfway and press in the OIL PRESSURE SWITCH and hold it.

NOTE

Continue holding in the OIL PRESSURE SWITCH until the OIL PRESSURE GAGE indicates 20 psi or more.

CAUTION

Do not hold start-magneto switch in the START position for more than 10 seconds or starter damage could occur. Make up to FIVE attempts to start engine. Be sure to pause three minutes between attempts. Refer to TM 9-2805-259-14, Starter Troubleshooting Procedures, if engine does not start on the fifth attempt.

- c. Pull manual CHOKE on control panel to help start engine. Turn the start-magneto switch to START to run the starter. As soon as the engine starts, release the start-magneto switch. The switch is spring-loaded to return to RUN.
- d. Release the OIL PRESSURE SWITCH.
- e. If the engine does not start, perform the instructions marked on the engine cover.

2-11. STARTING THE PUMP UNIT (CONT).

5

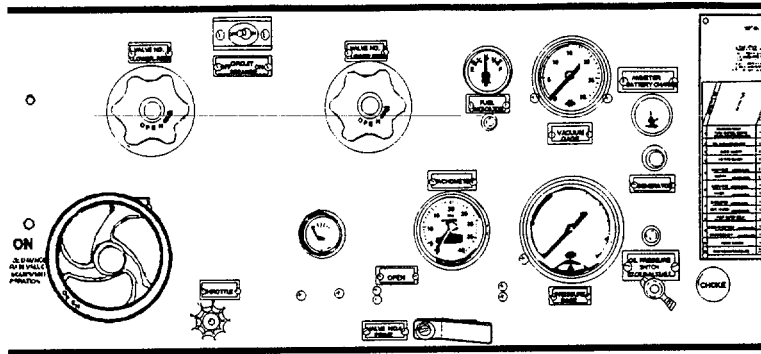

CAUTION

Close VALVE NO. 4 PRIME before the prime-detergent tank is empty. If the valve is not closed, all vacuum or pressure is lost due to air being drawn into the pump from the prime-detergent tank.

Close VALVE NO. 4 PRIME immediately when the pump is fully primed.

6

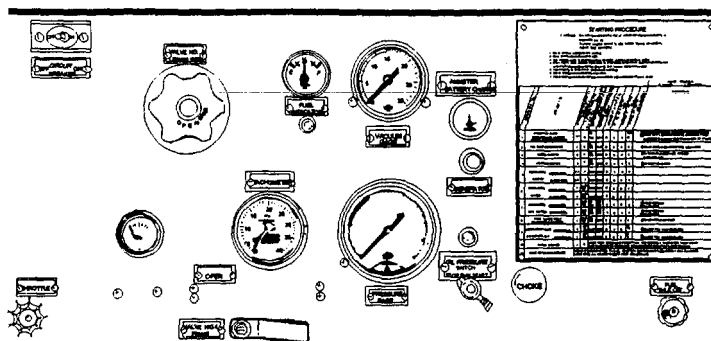
**NOTE**

Before applying the load, allow engine to warm up at idle RPM for 15 minutes. During operation in extreme cold temperatures (below 0°F), allow engine to warm up until it will maintain normal operation without aid of manual CHOKE.

- a. Adjust the THROTTLE to the desired pump speed. Increase the engine rpm by rotating the throttle clockwise until TACHOMETER indicates approximately 3,850 rpm.

NOTE

The governor on the engine is factory set to control the engine speed at 3,850 rpm. If the engine will not operate at 3,850 rpm, notify organizational maintenance personnel to adjust the governor. Suitable pressures to spray STB slurry properly, with two discharge hoses, cannot be obtained unless the engine will operate at 3,850 rpm. At that engine speed, the pump operates at 4,400 rpm.

- b. At first the water PRESSURE GAGE may indicate zero and the VACUUM GAGE may indicate from zero to fifteen inches of mercury depending on the height of the pump above the level of water. When the pump is fully primed, the sound of the pump will change noticeably and the water PRESSURE GAGE should indicate between 60 and 120 psi. (90 psi is a normal reading.)

2-12. STOPPING THE PUMP UNIT.

1

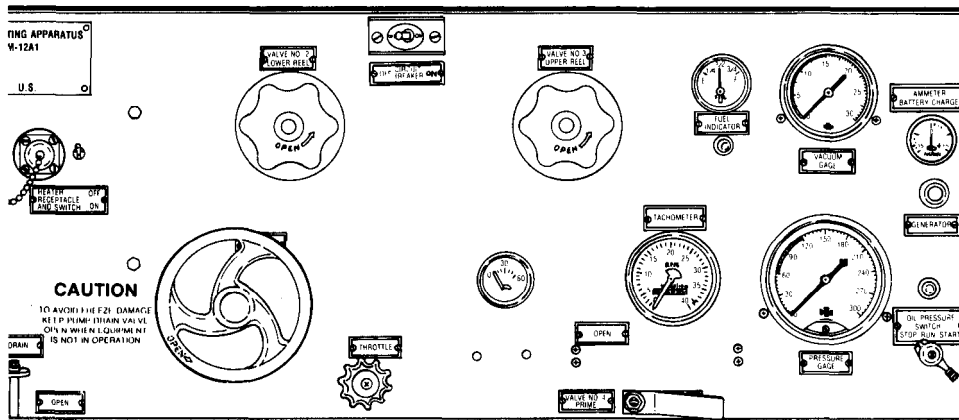

- a. Reduce engine speed to idle by turning the throttle on the control panel counter-clockwise. (Engine speed will decrease and pump pressure will drop.)

CAUTION

After removing the load, allow engine to run at idle RPM for at least 15 minutes before shutting down.

- b. Close the FUEL SHUT-OFF valve (1) on the control panel. Fuel from the gasoline tank is gravity fed to the carburetor and will flood the engine if the FUEL SHUT-OFF VALVE is left open.
- c. Close the finger nut (2) on the sediment bowl beneath the fuel tank.
- d. Turn the start-magneto switch to STOP.

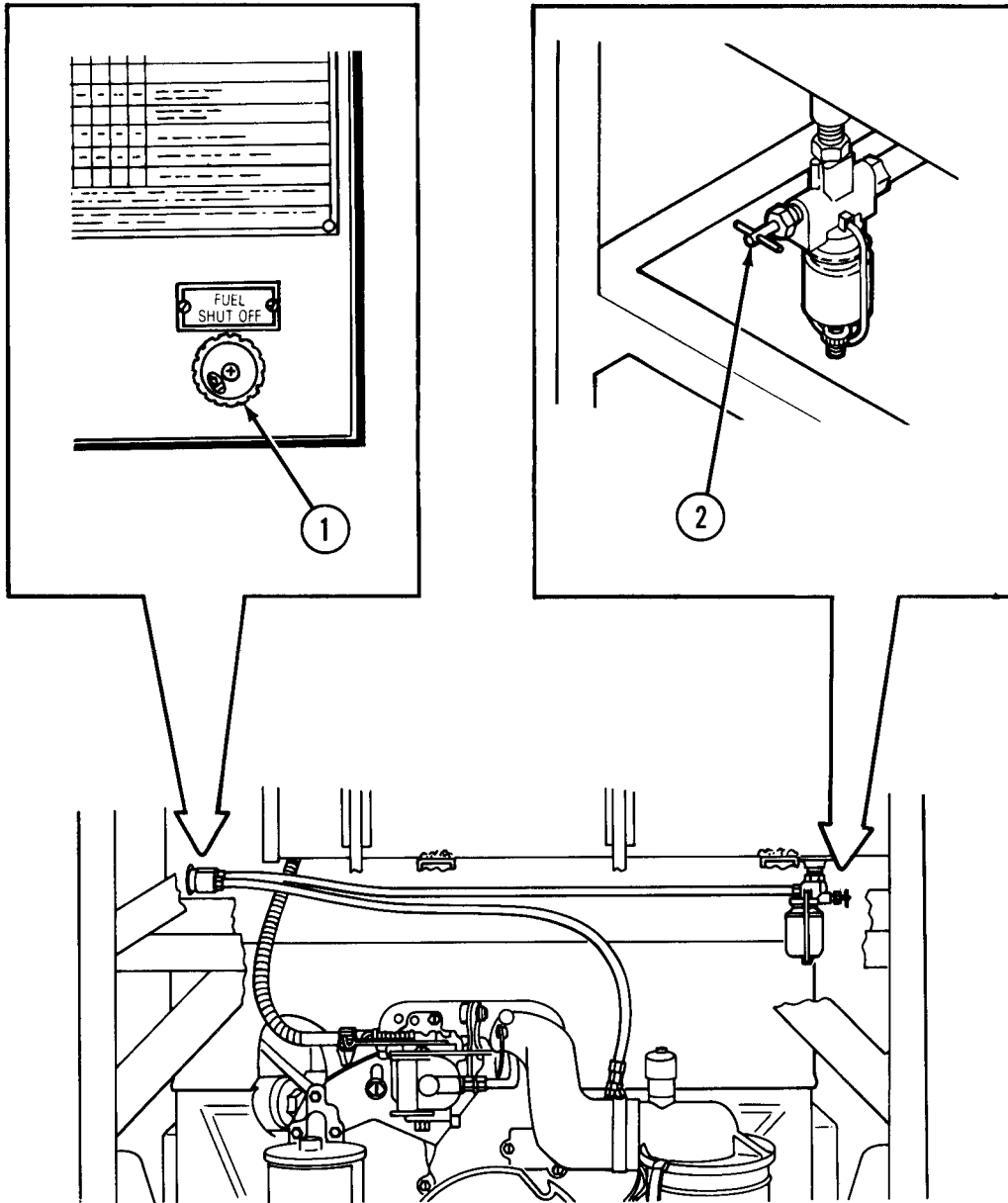

2-12. STOPPING THE PUMP UNIT (CONT).

2

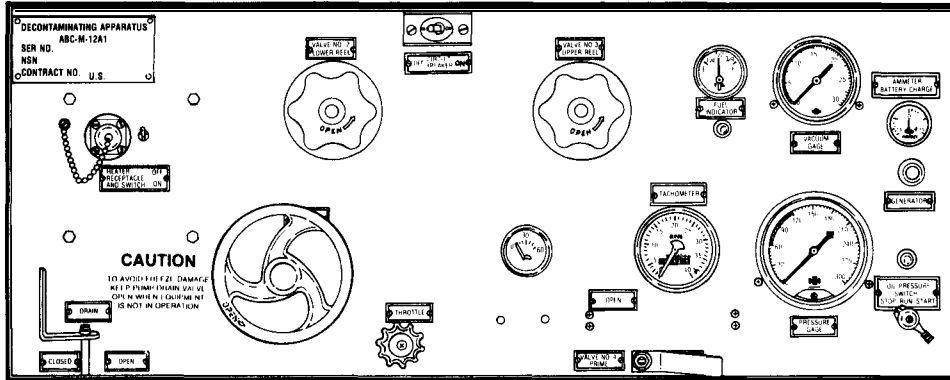

Close VALVE NOS. 1, 2, and 3. Make sure VALVE NO. 4 PRIME is closed.

3

- a. If the tank unit is used, close the tank drain valve on the tank unit assembly. Disconnect all hoses except the water heater hose from the top of the heater. Open the pump DRAIN valve to drain liquid from the piping and pump. Cap all pipes.

CAUTION

Be sure that water heater is cool before stowing the main electrical power cable and fuel lines in the storage compartment.

Stow hoses. Disconnect the electrical cable leading from the water heater at the connector on the pump unit assembly control panel. Stow the cable in the storage compartment.

- b. Disconnect the two exhaust pipe extensions from the two mufflers (2) on either side of the engine.

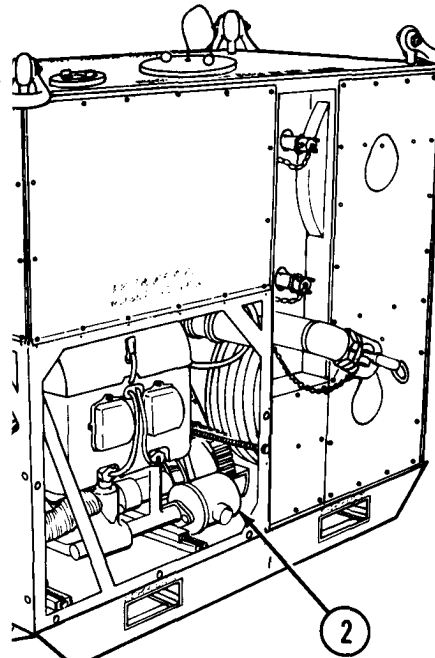

- c. After the spraying mission is complete, flush, drain, clean, and stow the apparatus according to the applicable procedure in table 2-4.

2-13. SPRAYING WATER FROM A NATURAL SOURCE.

NOTE

Under certain conditions (such as washing a large number of contaminated vehicles) water can be pumped from a natural source instead of loading the tank unit. The water can be discharged through two gun assemblies. When practical, place foot valve in an empty STB decontaminating drum or equivalent and immerse the foot valve.

1

OPERATION NO	OPERATION	PREVIOUS OPERATION REQUIRED	SUCKTION HOSE TO SOURCE	DISCHARGE TANK UPPER	DISCHARGE CONNECTION LOWER	VALVE #1 MANIFOLD	VALVE #2 LOWER REEL	VALVE #3 UPPER REEL	VALVE #4 PRIME DETERGENT	REMARKS
6	DISCHARGE	UPPER REEL	1	S/T	CAP CAP	O X	O X	X		
	WATER	LOWER REEL	1	S/T	CAP CAP	O O	X X	X		

VALVE POSITION
O - OPEN X - CLOSED

Follow operation number 6 on the STARTING PROCEDURE instruction plate.

2-13. SPRAYING WATER FROM A NATURAL SOURCE (CONT).

2

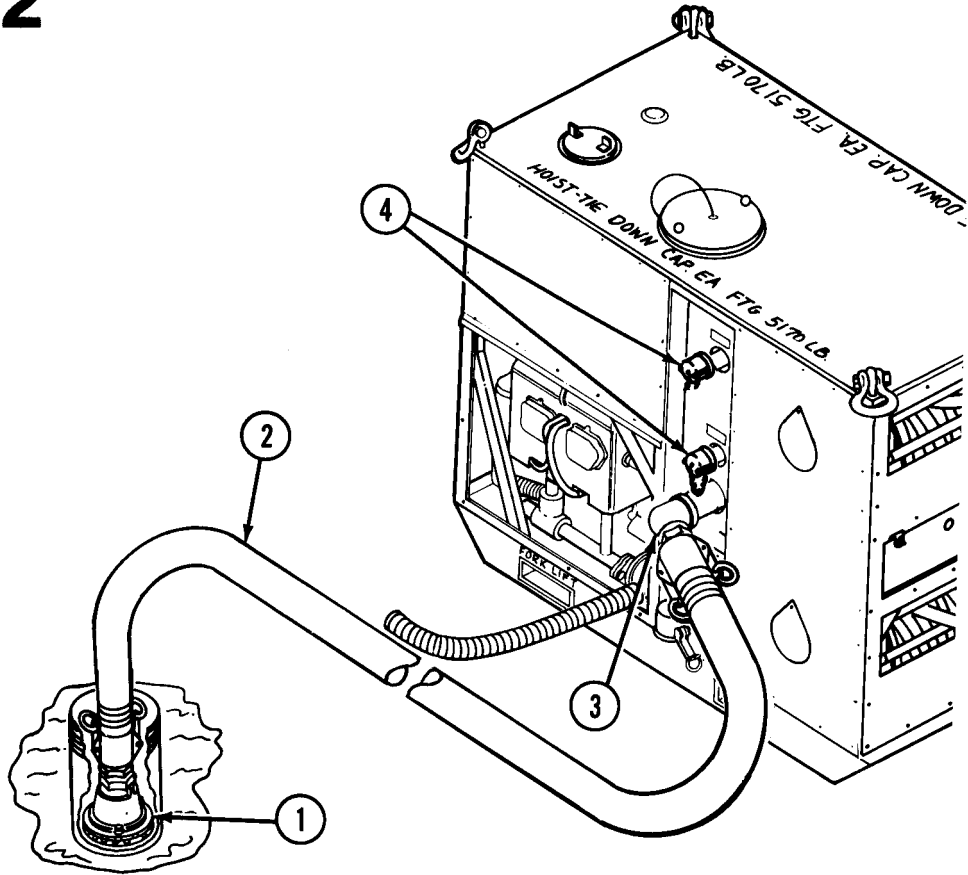

Connect the foot valve (1) to the suction hose (2). Connect the suction hose (2) to the pump unit (3). Cap the upper and lower discharge connections (4). Submerge foot valve in water source.

3

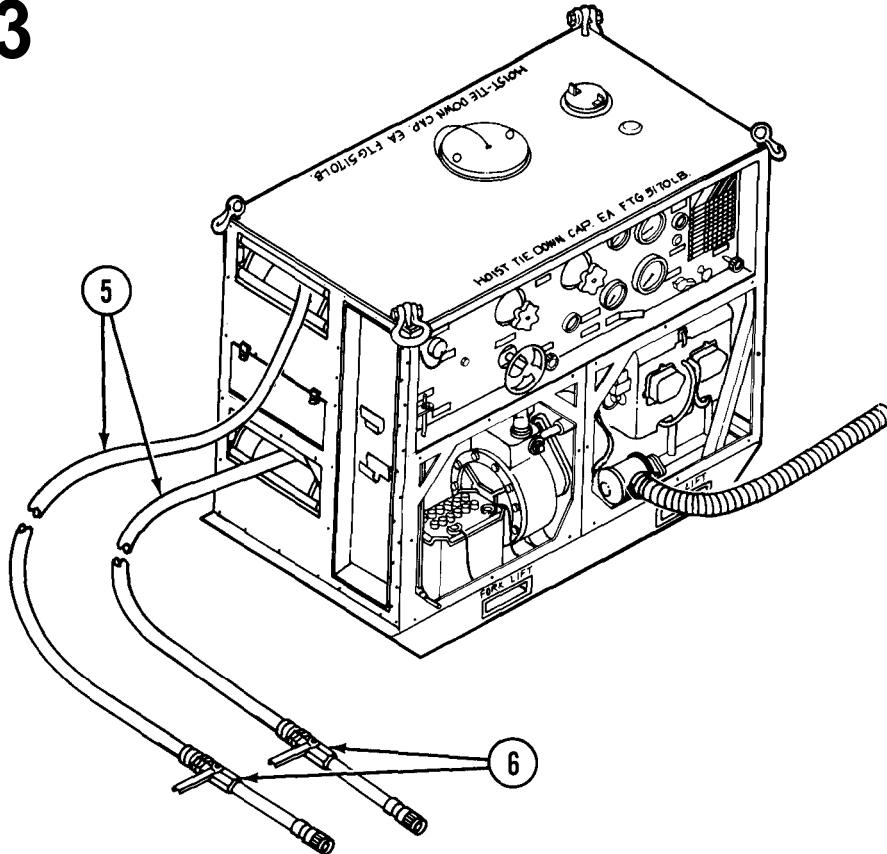

- a. Prime the pump and start the pump unit (see para 2-11). Unreel the discharge hoses (5) from the two hose reels.
- b. To spray from the upper reel, open VALVE NOS. 1 and 3. To spray from the lower reel, open VALVE NOS. 1 and 2. Open ball valve (6) on gun assembly to spray. Open the slurry nozzle's orifice and deflector assembly to produce the desired spray pattern.

NOTE

The pump discharge PRESSURE GAGE should indicate approximately 105 psi while spraying.

- c. After the spraying mission is complete, stop the pump unit 2-12. Clean and store the apparatus according to applicable procedure listed in table 2-4.

2-14. SPRAYING WATER FROM TANK.

1

OPERATION NO	OPERATION	PREVIOUS OPERATION REQUIRED	SUCTION HOSE TO SOURCE	DISCHARGE CONNECTION TO TANK	DISCHARGE CONNECTION LOWER	VALVE POSITION				REMARKS
						MANIFOLD	LOWER REEL	UPPER REEL	PRIME DELEGENT	
VALVE POSITION O - OPEN X - CLOSED										
6	DISCHARGE UPPER REEL	I	S/T	CAP	CAP	O	X	O	X	
	WATER LOWER REEL	I	S/T	CAP	CAP	O	O	X	X	

Follow operation number 6 on the STARTING PROCEDURE instruction plate.

2

Diagram illustrating the connection of a suction hose (1) to the tank drain valve (2) and the pump unit connection (3). The diagram shows a fire tank on the left and a pump unit on the right. A suction hose (1) is connected to the tank drain valve (2) and the pump unit connection (3). The tank has a label: "AIR TRANSPORT WEIGHT EMPTY 936 LBS WITH 574 GALLONS WATER 4060 LBS." The pump unit has a label: "MUST BE DOWN CAP. EA FT6 5170 LA." and "PUMP UNIT".

- Connect one end of suction hose (1) to the tank drain valve (2) and the other end to the pump unit connection (3).
- Cap the upper and lower discharge connection,
- Open tank drain valve (2).

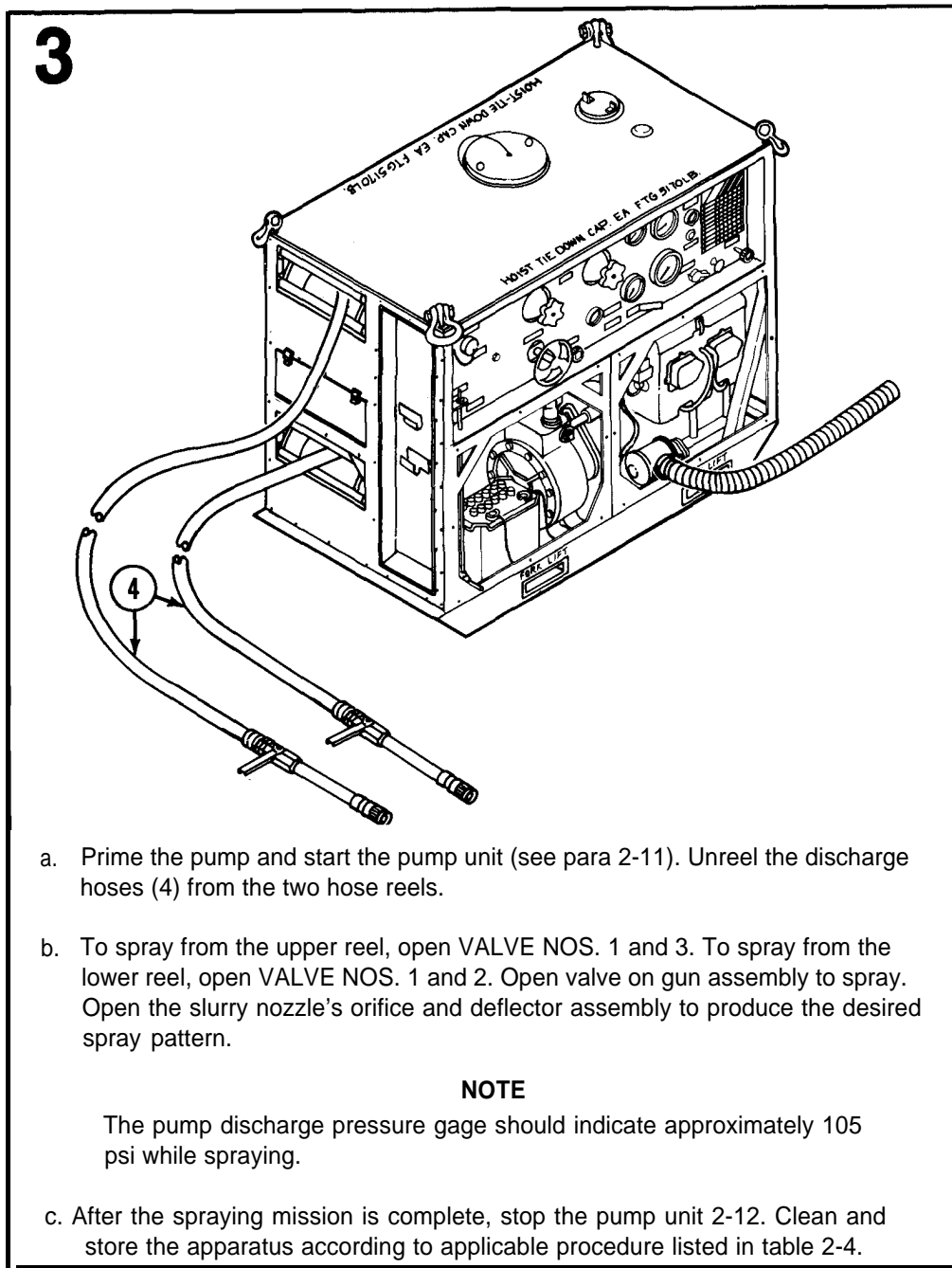

2-15. LOADING TANK FROM A PRESSURE SOURCE.

CAUTION

Always use the cleanest water available. Grit or dirt in water under pressure will damage the pump and hose nozzles.

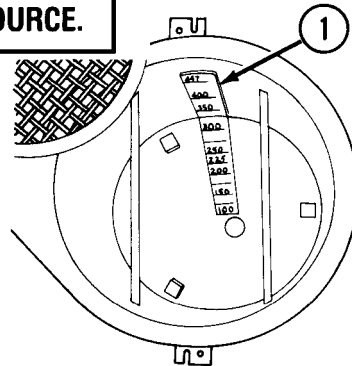

The working capacity of the tank unit is approximately 447 gallons. When water only is to be loaded, fill the tank to the 447 gallon capacity. When STB decontaminating agent (item 7, app D) is to be added, fill the tank with only 225 gallons of water. If necessary remove screen to read the tank liquid level indicator (1).

1

Remove cover (2). Load water from a hydrant or tank truck by inserting a hose (3) (not part of the decontaminating apparatus) in the hopper-blender.

NOTE

An alternate method of filling from a pressure source is to use the suction hose provided with the decontaminating apparatus. First, attach one end to the tank drain valve. Then, using a suitable adapter (not part of the decontaminating apparatus), connect the opposite end of the suction hose to the pressure source. Open the tank drain valve and monitor the filling progress on the tank liquid level indicator because it can be very rapid.

2-16. LOADING TANK FROM A NATURAL SOURCE.

NOTE

If the height from the natural water source to the pump is not more than 15 feet, water can be loaded from a stream, pond, or other natural source by using the suction hose and foot valve assembly.

1

OPERATION NO.	OPERATION	PREVIOUS OPERATION REQUIRED	SUCTION HOSE TO SOURCE	DISCHARGE TO TANK	DISCHARGE CONNECTION UPPER LOWER	VALVE #1 MANIFOLD	VALVE #2 LOWER REEL	VALVE #3 UPPER REEL	VALVE #4 PRIME DETERGENT	VALVE POSITION	REMARKS
										O - OPEN	
2	FILL TANK WITH WATER	1	S	ON CAP	O	X	X	X			*TO AGITATOR CONNECT ONE INCH HOSE

Follow operation number 2 on the STARTING PROCEDURE instruction plate.

2

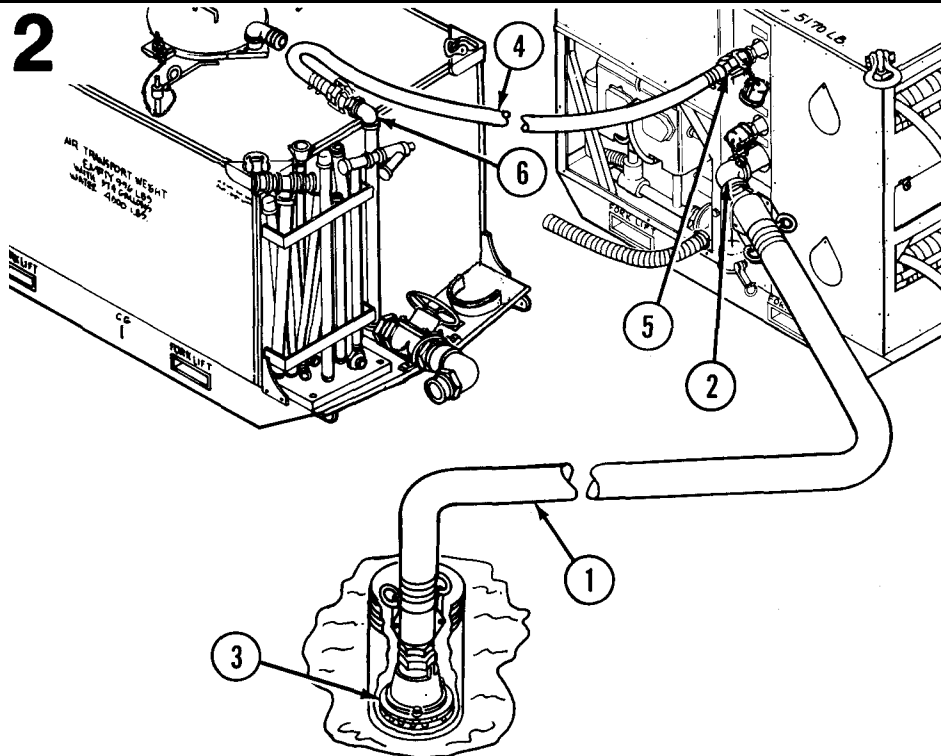

- Connect one end of the suction hose (1) to the pump unit connection (2) and the other end to the foot valve assembly (3). When practical, place the foot valve (3) in an empty STB decontaminating drum or equivalent and immerse the foot valve.
- Couple one end of the agitator-blender hose (4) to the pump unit upper discharge pump connection (5) and the other end to the agitator connector (6) on the tank unit.

2-16. LOADING TANK FROM A NATURAL SOURCE (CONT).

3

a. Open VALVE NO. 1.

b. Prime the pump, start the pump unit (see para 2-11), and fill the tank with water.

4

After loading the tank with water, stop the pump unit (para 2-12). Disconnect suction hose (1) from foot valve assembly (3). (Stow the foot valve assembly.) Connect the free end of the suction hose (1) to the tank drain quick-disconnect coupling half (7). Open the tank drain valve (8).

2-17. HEATING WATER.**WARNING**

If the pump unit assembly and the water heater are operated in an inclosed area, the exhausts must be vented outside the inclosed area to prevent carbon monoxide poisoning. A chemical-biological mask does not protect against carbon monoxide fumes.

CAUTION

Circulate only clean water through the water heater. Do not circulate slurry or any other mixture through the water heater. Do not use the heater when metering fluids into the pump from the prime-detergent tank.

NOTE

Two procedures may be used for heating water depending on if water is to be drawn from a natural source, heated, and discharged or if water in the tank is to be heated. Generally if water is heated in the tank, higher water temperatures can be reached since the water can pass through the water heater more than once.

WARNING

Keep clear of the exhaust stack during operation of the water heater. A chemical-protective mask does not protect against carbon monoxide gas.

CAUTION

To prevent damage to the water heater, place the HEATER RECEPTACLE AND SWITCH on the pump unit control panel to ON and operate the pump unit for two minutes with the heater control switch to PURGE ON before igniting the boiler. This ensures that the boiler is filled with water and that all air is out of the lines.

NOTE

An operator must be in attendance at all times during operation of the water heater.

2-17. HEATING WATER (CONT).

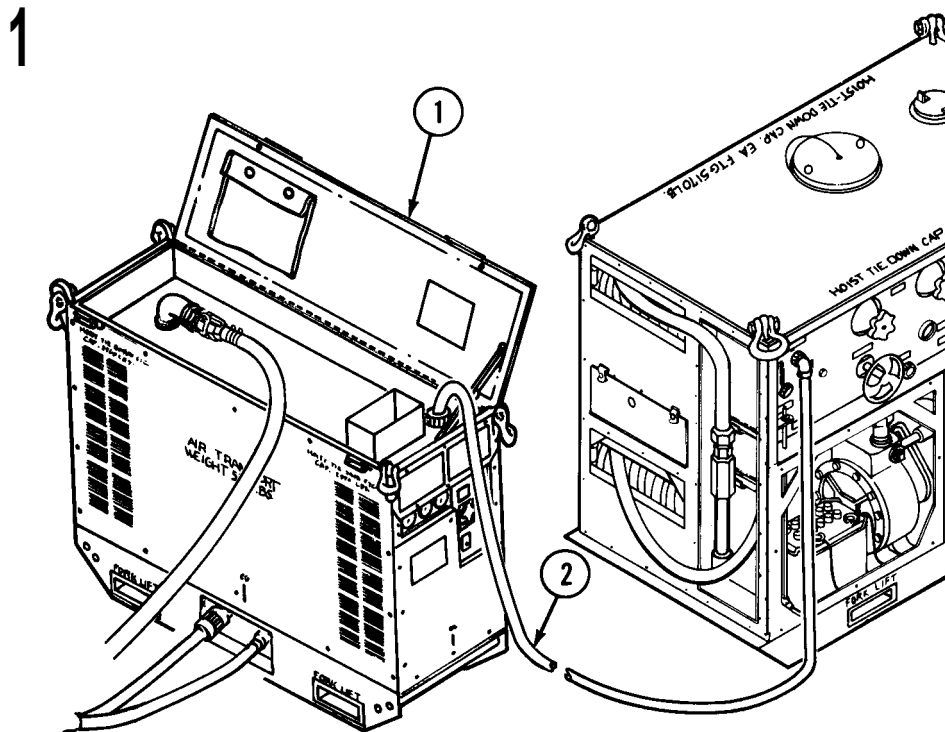

NOTE

The heater operating instruction plates provides additional heater operating instructions.

- a. Open the storage compartment door (1) on top of the water heater. Leave it open.
- b. Remove the electrical power cable (2) from the storage compartment.

NOTE

One end of the power cable passes through the stuffing tube and is connected inside the control box. Do not disconnect this end of the power cable.

- c. Uncap the HEATER RECEPTACLE AND SWITCH socket on the control panel of the pump unit assembly and plug the free end of the power cable (2) into the socket. Make certain that the power cable does not pass over the exhaust stack.
- d. Connect hoses necessary for mode of operation. Open valves necessary for operation. Refer to STARTING PROCEDURE instruction plate on the pump unit or following paragraphs for the specific operation required.

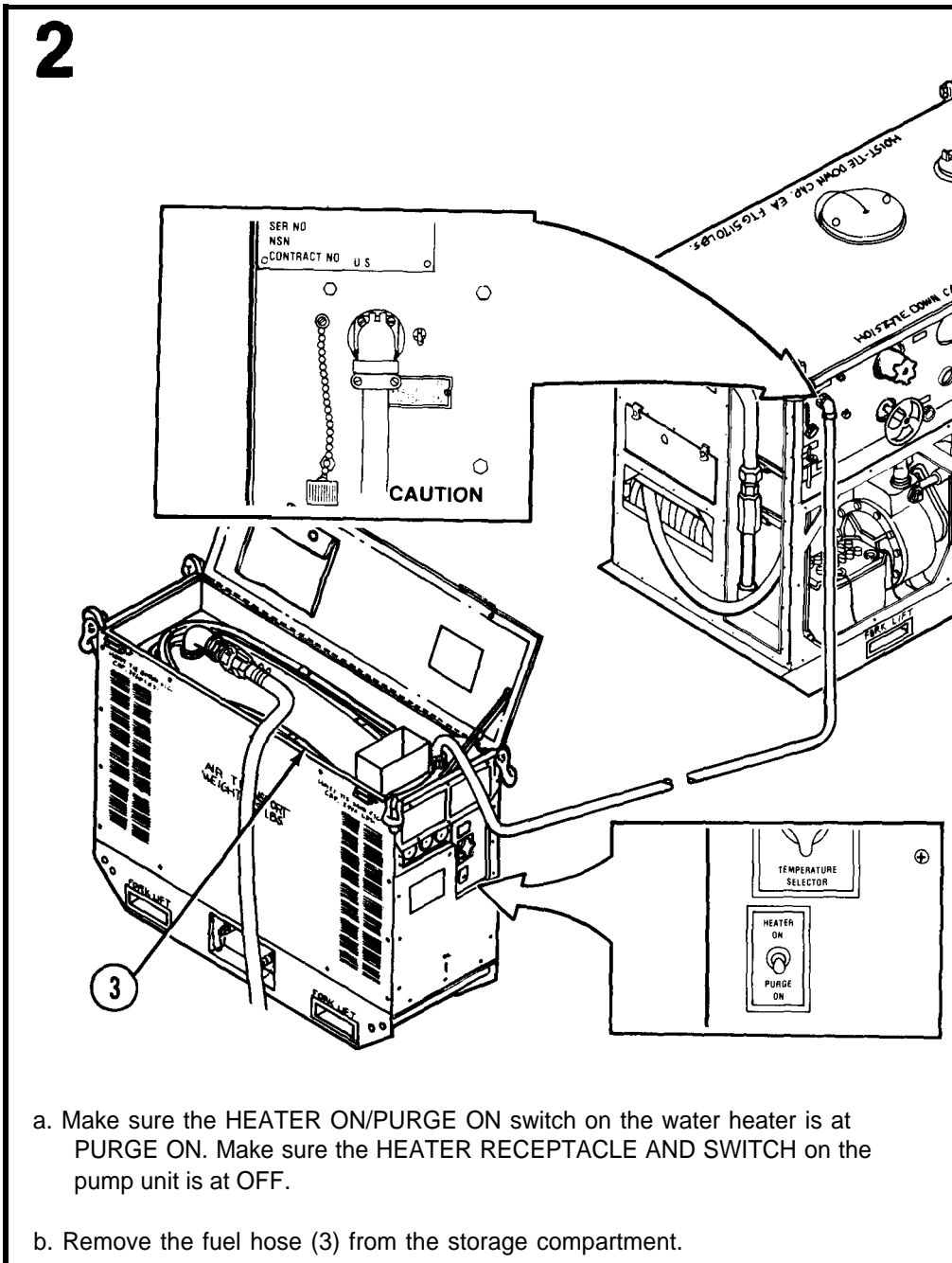

2-17. HEATING WATER (CONT).

3

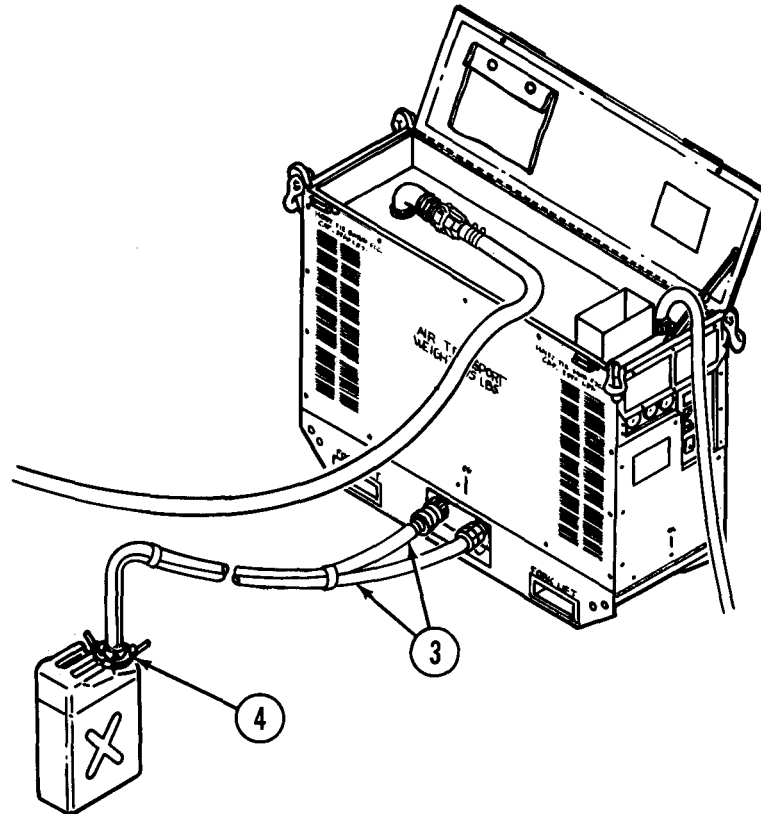

CAUTION

Use fuel hose with the 5-gallon can only. Do not use a vehicle gas tank or a 55-gallon drum as a fuel source. The 5-gallon can controls vapors and suppresses electrical sparks.

- a. Connect the fuel tank plug (4) into 5 gallon gasoline can. Screw the fuel tank plug down handtight.
- b. Remove the caps from the quick-disconnect couplings for the fuel supply and return lines in the skid assembly base. Connect the fuel supply and return hose quick-disconnect coupling halves to the connectors. Pull on the connected hoses (3) to make certain they are securely fastened.

4

- a. Prime the pump. Start the pump unit (see para 2-11). Place HEATER RECEPTACLE AND SWITCH to ON. Pump water heater full of clean water. Operate in PURGE ON for at least two minutes.

CAUTION

When using gasoline to power the boiler, pour 1 pint of grade 30 motor oil (item 18, app D) per 5 gallons of gasoline into the fuel container to prevent freeze-up and damage to the fuel pump.



- b. Place the heater control switch to HEATER ON. Quickly adjust the TEMPERATURE SELECTOR control valve to produce an indication on the FUEL PRESSURE gage for the type of fuel being burned as indicated in the following table.

Fuel	Setting
Gasoline75 psi
Turbine Engine Fuel, Grade JP4, JP575 psi
Kerosene70 psi
Burner Fuel Oil, Grade No. 260 psi
Diesel Fuel60 psi

2-17. HEATING WATER (CONT).

5

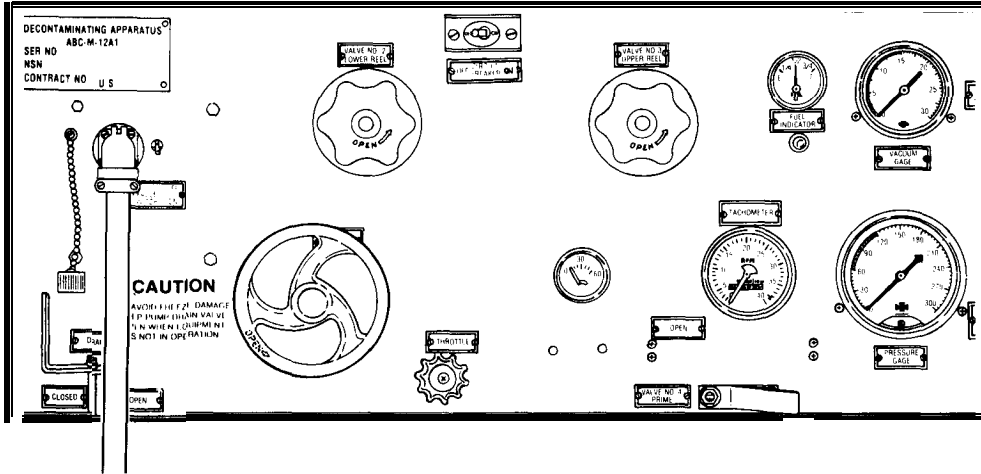

WARNING

If the water heater does not ignite in 10 seconds, place the heater control switch to PURGE ON. Do not attempt to start the water heater. Refer to chapter 3, section II, for operator troubleshooting procedures. Remove electrical power by placing the HEATER RECEPTACLE AND SWITCH on the pump unit to OFF.

- a. Operate the water heater for approximately five minutes. Then readjust the TEMPERATURE SELECTOR control gradually to produce the desired water temperature. Do not allow the temperature of water in the boiler to exceed 200°F(± 12). If it does, the heater will automatically shutoff.
- b. Water maybe discharged through the gun assemblies or through the shower by opening either VALVE NOS. 2 or 3 (location illustrated) while water is being heated. Also when the heater is in operation, fresh water maybe continuously added to the tank from a hydrant or hose. VALVE NO. 1 can control the temperature of water by metering the water flow through the heater. Do not allow the pump pressure to fall below 60 psi.

2-18. STOPPING THE WATER HEATER.

1

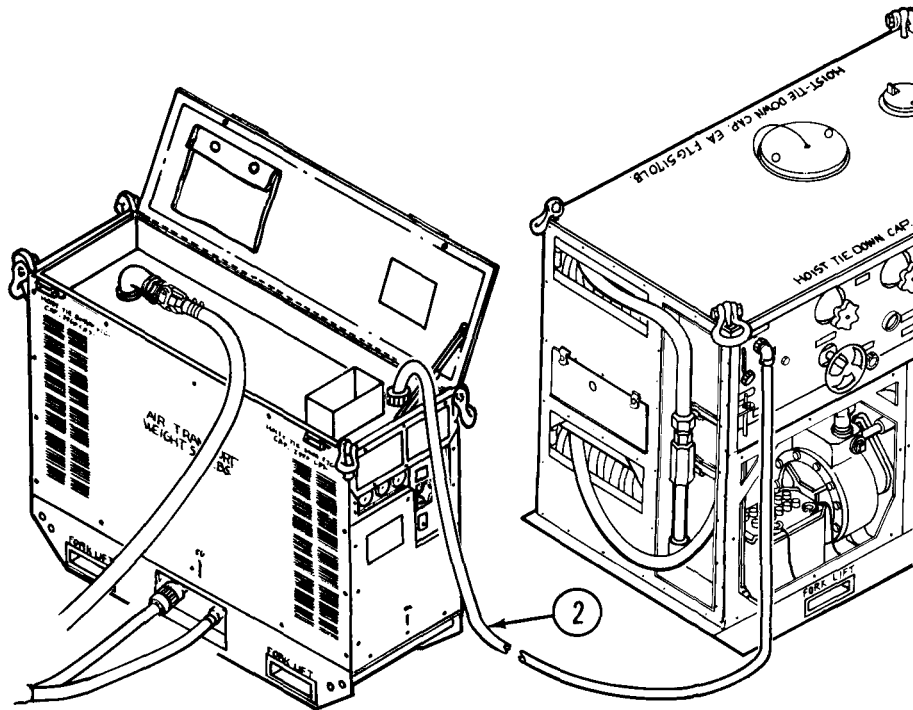

- a. When the required amount of water is heated to the desired temperature, stop the water heater by performing the following steps.
- b. Place the heater control switch to PURGE ON. After combustion ceases, operate for two minutes in PURGE ON.
- c. Place HEATER RECEPTACLE AND SWITCH on pump unit to OFF.
- d. Continue to cycle water through the boiler for at least three minutes or until the water temperature is approximately 100° F as indicated on the WATER TEMPERATURE gage.

CAUTION

Insure that water heater is cool before storing the main electrical power cable and fuel hoses in the storage compartment.

- e. Disconnect the main electrical power cable (2). Cap HEATER RECEPTACLE AND SWITCH socket. Stow the main electrical power cable neatly in the storage compartment of the water heater.

2-18. STOPPING THE WATER HEATER (CONT.)

2

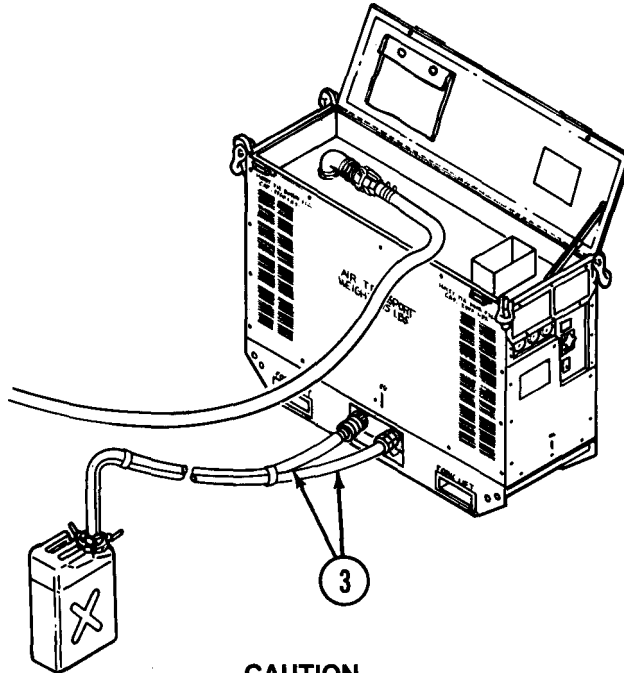

CAUTION

Let water heater cool before disconnecting fuel lines.

- a. Disconnect the fuel supply and the fuel return lines of the fuel hose (3) from the water heater. Reconnect the caps on the quick disconnect couplings for the fuel supply and fuel return lines.
- b. Drain remaining fuel in the fuel hose into the gasoline can. Remove the fuel hose from the gasoline can. Install a cap on the gasoline can.

3

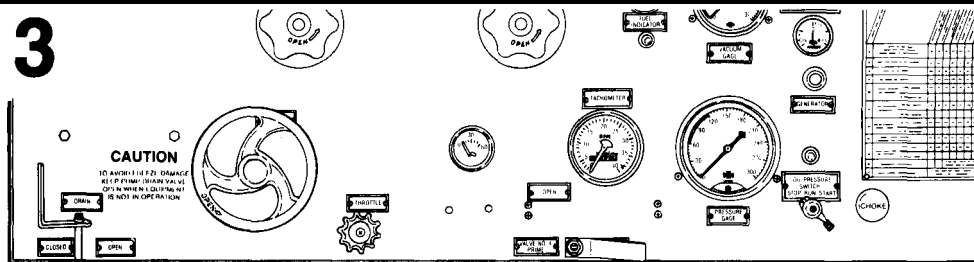

- a. Stop the pump unit assembly by reducing engine speed to idle, closing the fuel SHUT OFF VALVE and turning the start-magneto switch to STOP (see para 2-12).
- b. Close all valves opened for operation.

4

WARNING

If it is necessary to disconnect the hoses with the water temperature above 100° F (38° C), exercise extreme care to prevent scalding.

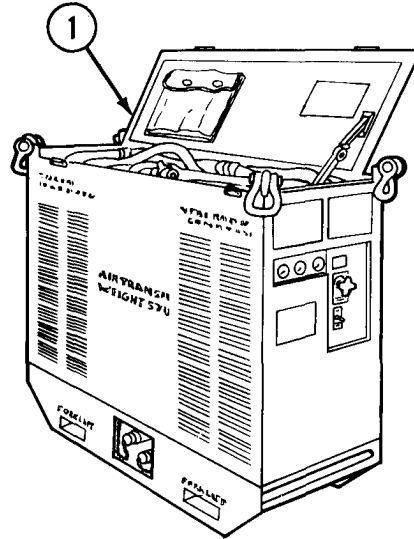

- a. Disconnect the blender hose from the heater base and make the appropriate connections for the next operation. For shutdown, coil water hose neatly in storage compartment. Allow the water heater to drain. It will drain completely through the water inlet.
- b. Install protective cap on heater inlet.
- c. Close and latch storage compartment door (1).

2-19. HEATING WATER DRAWN FROM A NATURAL SOURCE.

1

OPERATION NO	OPERATION	PREVIOUS OPERATION REQUIRED	SUCTION HOSE TO SOURCE	DISCHARGE HOSE TO TANK	DISCHARGE CONNECTION UPPER LOWER	VALVE #1	MANIFOLD	VALVE #2	LOWER REEL	VALVE #3	UPPER REEL	VALVE #4	PRIME DETERGENT	VALVE POSITION		REMARKS
														O—OPEN	X—CLOSED	
7	DISCHARGE UPPER REEL	1	S/T	• ON	** ON	X	X	O	X							*FROM HEATER **TO HEATER
7	HOT WATER LOWER REEL	1	S/T	• ON	** ON	X	O	X	X							*FROM HEATER **TO HEATER

NOTE

If the tank cannot be filled prior to heating water, water from a natural source can be heated by pumping it directly through the heater.

Follow operation number 7 on the STARTING PROCEDURE instruction plate.

2-19. HEATING WATER DRAWN FROM A NATURAL SOURCE (CONT).

2

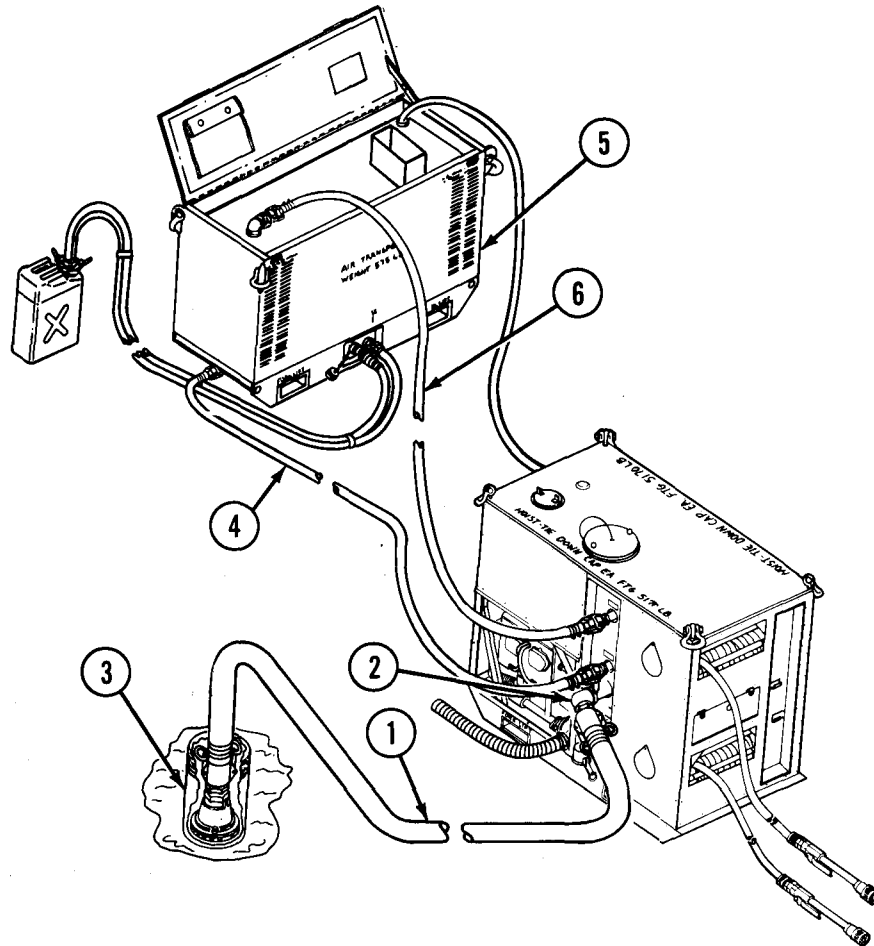

- a. Make sure VALVE NO. 1 is closed.
- b. Connect one end of suction hose (1) to the suction connection on the pump unit (2) and the other end to the foot valve assembly (3). When practical, place the foot valve in an empty STB decontaminating drum or equivalent and immerse the foot valve.
- c. Connect one end of blender hose (4) to pump unit bottom discharge connection and other end to water heater (5) bottom connection.
- d. Connect one end of heater unit water hose (6) to pump unit upper discharge piping, and the other end to water heater (5) upper connection.

3

a. Make sure VALVE NOS. 2 and/or 3 are open. Hot water can be sprayed through the upper and/or lower reels and out discharge hose(s).

b. Prime and start the pump unit (see para 2-11).

c. Start and run the water heater according to paragraph 2-17.

d. After mission is complete, stop the water heater (see para 2-18).

e. Stop the pump unit (see para 2-12).

f. After the mission is complete, clean and store the apparatus according to the applicable procedure listed in table 2-4.

2-20. HEATING WATER FROM THE TANK.

1

OPERATION NO	OPERATION	PREVIOUS OPERATION REQUIRED	SUCTION HOSE TO SOURCE	DISCHARGE HOSE TO TANK	DISCHARGE CONNECTION UPPER	DISCHARGE CONNECTION LOWER	VALVE #1 MANIFOLD	VALVE #2 LOWER REEL	VALVE #3 UPPER REEL	VALVE #4 PRIME DETERGENT	VALVE POSITION		REMARKS
											O—OPEN	X—CLOSED	
7	DISCHARGE UPPER REEL	1	S/T	ON	ON	X	X	O	X			*FROM HEATER **TO HEATER	
	HOT WATER LOWER REEL	1	S/T	ON	ON	X	O	X	X			*FROM HEATER **TO HEATER	

Follow operation number 7 on the STARTING PROCEDURE instruction plate.

2-20. HEATING WATER FROM THE TANK (CONT).

2

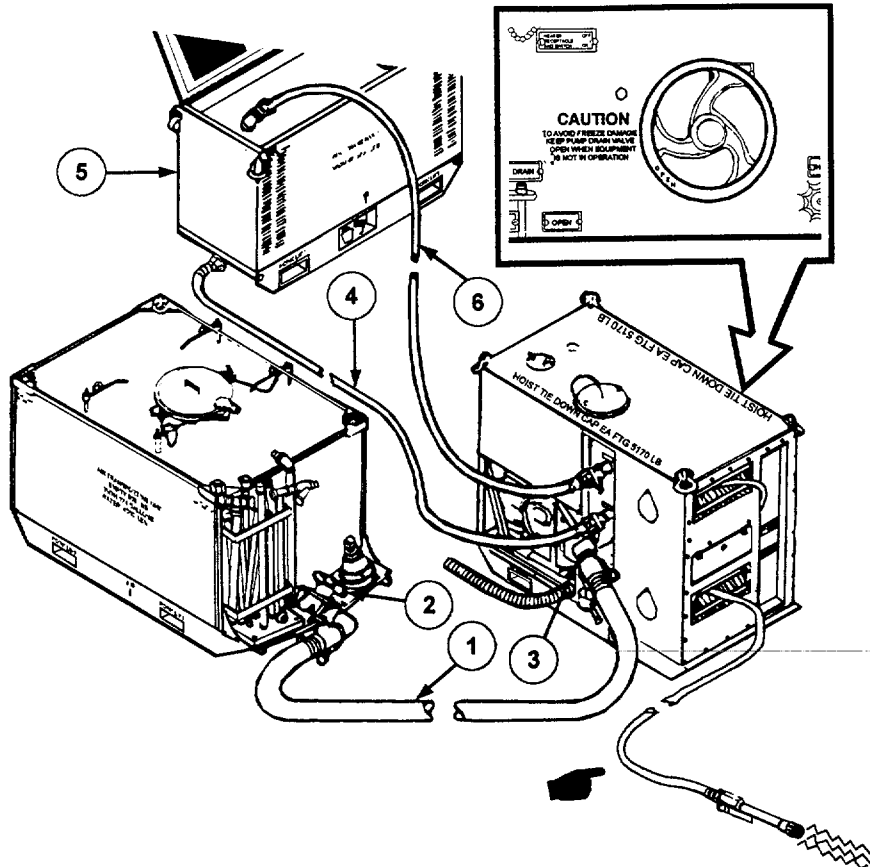

- a. Make sure VALVE NO. 1 on the pump unit is closed.
- b. Connect one end of suction hose (1) to tank unit drain valve (2) and other end to suction connection on pump unit (3). Open tank drain valve (2).
- c. Connect one end of blender hose (4) to bottom discharge connection on pump unit and other end to bottom connection on water heater (5).
- d. Connect free end of heater unit water hose (6) to upper discharge piping on pump unit and other end to upper connection on water heater.

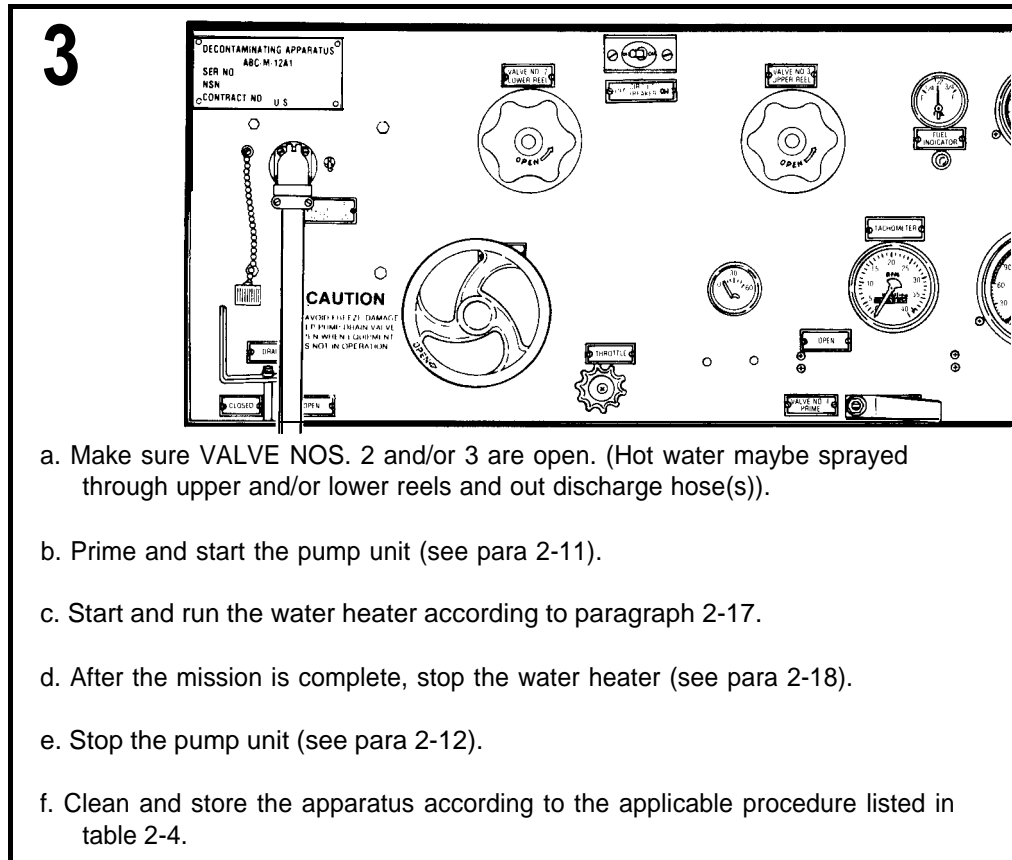

2-21. MAKING STB DECONTAMINATING AGENT SLURRY.

WARNING

Do not use antifreeze with STB. Heat releasing reaction occurs.

a. *General.* When preparing slurry, add the M2 antiset (item 2, app D) to the water first. Mix water with M2 antiset for three minutes. Next add the silicone antifoam agent (item 1, app D). Mix silicone antifoam agent for at least three minutes before adding the STB decontaminating agent (item 7, app D). Prepare the slurry as near to using time as possible. Never prepare slurry more than four hours in advance of use. STB will dissolve more rapidly in hot water.

2-21. MAKING STB DECONTAMINATING AGENT SLURRY (CONT).

b. *M2 Antiset (item 2, app D)*. The M2 antiset retards setting of the slurry. If M2 antiset is not added, especially in cold weather, the slurry will set rapidly and will form a hard mortar-like mass that will clog the tank and lines. Add M2 antiset in the proportion of 1 pound to each 100 pounds of STB agent for small quantities of slurry or one 12-1/2 pound package of M2 antiset per 1,300 pounds of STB decontaminating agent (225 gallons of water). Remove the hopper tank lid and load the M2 antiset into the tank through the hopper-blender.

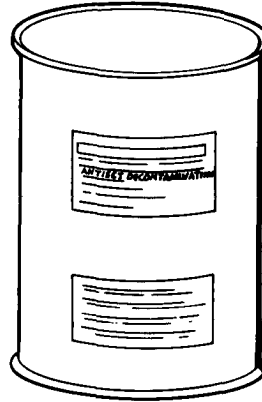

**M2 ANTISET
12 1/2 LB DRUM**

c. *Silicone Antifoam Agent (item 1, app D)*. Add approximately 24 ounces of silicone antifoam agent to the mixture to prevent foaming of the slurry for a filling of the tank (225 gallons). Adding silicone antifoam agent to the mixture does not affect the decontaminating properties of the STB decontaminating agent.

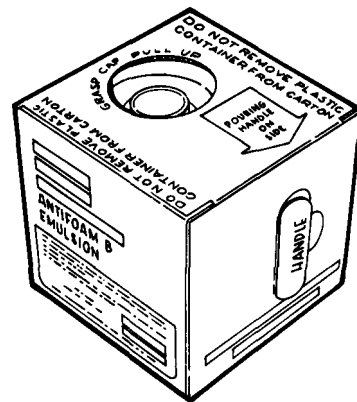

SILICONE ANTIFOAM AGENT

WARNING

Use caution when opening drums of Super Tropical Bleach (STB). Avoid contact with skin or eyes. Avoid contamination with acids and oxidizable materials such as fuels, oils, paint products, disinfectants, and ammonia. Such contamination can cause release of hazardous gases. Keep container closed and stored in a cool dry place. Mix only in accordance with directions for use. In case of contact with skin or eyes, immediately flush continuously with water; for eyes get medical attention.

d. *STB Decontaminating Agent (item 7, app D)*. The most effective mixture of water and STB decontaminating agent is prepared by mixing 40 parts (by weight) of STB decontaminating agent with 60 parts (by weight) of water (8.3 lbs per gallon). The decontaminating apparatus accommodates a mixture of 1,300 pounds of STB with 225 gallons of water. This mixture provides approximately 317 gallons of slurry which weighs about 10 pounds per gallon.

NOTE

If less than 317 gallons of slurry are required, decrease all ingredients proportionately. That is, if one-half (158 gallons) of slurry mix is to be prepared, use approximately 115 gallons of water, 650 pounds of STB decontaminating agent, 6-1/2 pounds of antiset compound, and 12 ounces of silicone antifoam agent.

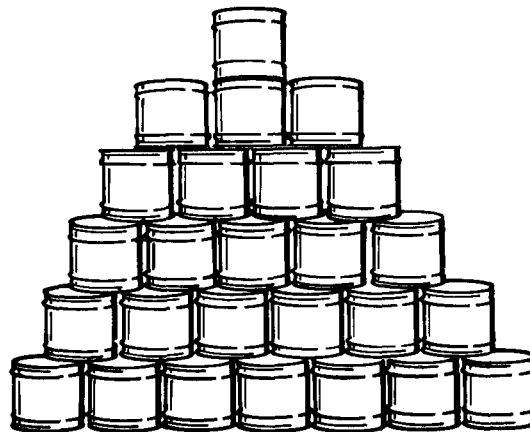

STB DECONTAMINATING AGENT

e. *Coverage of Slurry*. The following table gives normal coverage of slurry for different types of surfaces.

Type of Surface	Coverage	
	(Per gallon)	(Per filling)
Concrete road (smooth)	4.4 sq yd	350 sq yd
Macadam or gravel road (loosely surfaced)	2.2 sq yd	675 sq yd
Short grass (3 to 5 in.)	1.5 sq yd	464 sq yd
Long grass and low brush	1 sq yd	310 sq yd

FM 3-5 gives additional decontaminating information.

2-21. MAKING STB DECONTAMINATING AGENT SLURRY (CONT).

f. *Adding and Blending M2 Antiset and Silicone Antifoam Agent.*

1

OPERATION NO	OPERATION	PREVIOUS OPERATION REQUIRED	SUCTION HOSE TO DISCHARGE TANK	DISCHARGE CONNECTION LOWER	VALVE #1 MANIFOLD LOWER	VALVE #2 LOWER	VALVE #3 LOWER	VALVE #4 REEL	PRIME DETERGENT	VALVE POSITION		REMARKS
										O - OPEN	X - CLOSED	
3	BLEND SLURRY	2	T	ON	CAP	O	X	X	X			*TO TANK BLENDER ADD ANTISET THEN ADD STB

Follow operation number 3 on the **STARTING PROCEDURE** instruction plate.

2

- Fill the tank with the desired amount of water (para 2-15 and 2-16). Check tank liquid level indicator (1).
- Connect the suction hose (2) to the tank drain valve (3) and the connection on the pump unit (4) as illustrated.
- Connect agitator-blender hose (5) to pump unit (4) top discharge connection and to tank unit blender pipe (6).
- Be sure that bolts holding hopper-blender are in place and tightened.

3

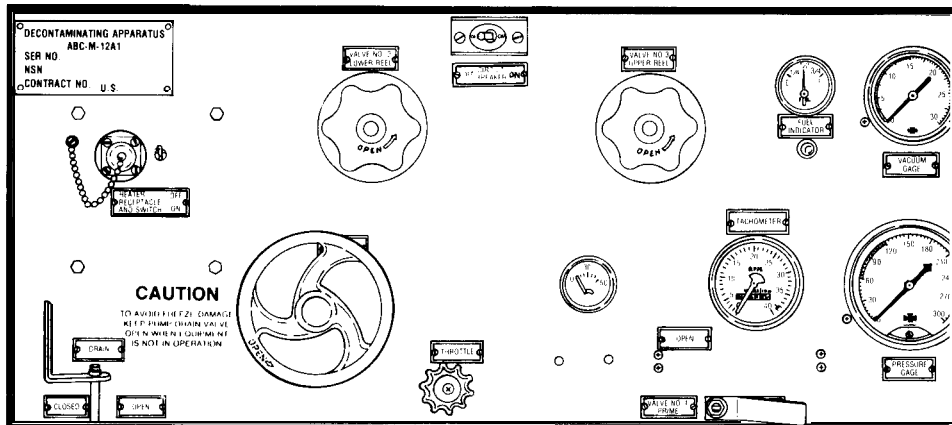

- a. Start the pump unit (see para 2-11). Open VALVE NO. 1 for this operation. Remove the hopper tank lid.

CAUTION

Cycle water containing M2 antiset for at least three minutes. The M2 antiset must be completely dissolved.

NOTE

If the M2 antiset is caked, it must be crushed as fine as possible before adding it to the water in the tank unit assembly.

- b. Add the M2 antiset and silicone antifoam agent. Operate for three minutes to fully blend these additives.

4

To prepare STB decontaminating agent for loading, open the 26 cans of STB decontaminating agent (item 7, app D).

NOTE

Before starting the loading and blending operations, break up the large lumps of STB to prevent clogging of the lines and to ensure the best possible water-slurry mixture. To prevent damage to the equipment, do not strike the metal drums containing the STB decontaminating agent against the tank or any other part of the tank unit.

2-21. MAKING STB DECONTAMINATING AGENT SLURRY (CONT).

5

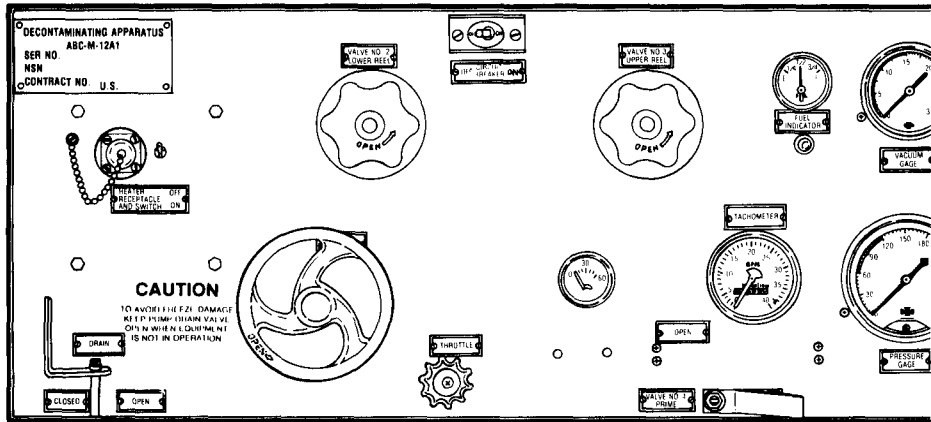

- a. Add the 1,300 pounds of STB decontaminating agent (item 7, app D) in one continuous operation. When loading agent, see that hopper does not run out of STB decontaminating agent. If the supply of agent is exhausted before loading is completed, the slurry in the tank may foam. Stop foaming by adding additional silicone antifoam agent.

CAUTION

After the slurry is blended, it must be agitated constantly until used.

- b. After blending is complete, replace tank lid. Agitate the slurry mixture.

g. Agitating Slurry in Tank Unit.

1

OPERATION NO	OPERATION	PREVIOUS OPERATION REQUIRED	SUCTION HOSE TO SOURCE	DISCHARGE TO TANK UPPER CONNECTION	DISCHARGE TO TANK LOWER CONNECTION	VALVE #1 MANHOLD	VALVE #2 LOWER	VALVE #3 UPPER	VALVE #4 URINE DETERGENT	VALVE POSITION		REMARKS
										O - OPEN	X - CLOSED	
4	AGITATE SLURRY	3	T	ON	CAP	O	X	X	X			*TO TANK AGITATOR

Follow operation No. 4 of the STARTING PROCEDURE instruction plate.

2

CAUTION

To ensure that VALVE NO. 1 is completely closed, check to see if slurry has flooded back into the tank unit as indicated on the tank liquid level indicator.

- a. Adjust engine speed to an idle.
- b. With the pump unit still operating, close VALVE NO. 1.

3

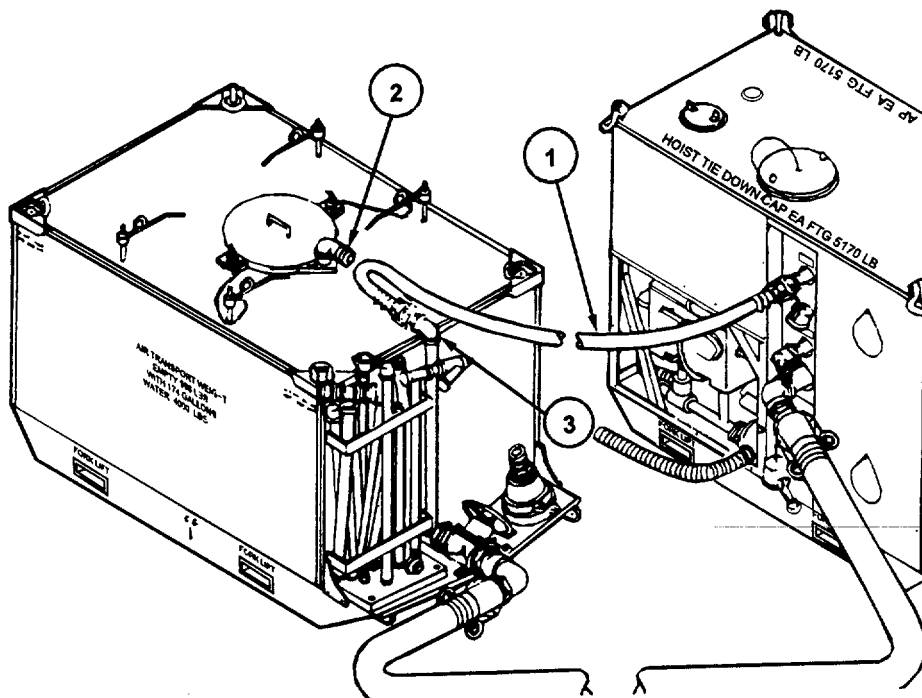

- a. Disconnect the agitator-blender hose (1) from the blender pipe (2) on the tank unit and connect the hose to the agitator pipe (3).
- b. Open VALVE NO. 1. Agitate for a minimum of 15 minutes by operating the engine at 3,850 rpm. The pump discharge pressure gage should indicate approximately 105 psi. Continue agitating slurry until it is used.

2-21. MAKING STB DECONTAMINATING AGENT SLURRY (CONT).

h. Spraying Slurry From Tank.

1

OPERATION NO.	OPERATION	PREVIOUS OPERATION	REQUIREMENTS	SIGNALS	DISCHARGE HOSE TO	DISCHARGE CONNECTION	VALVE NO.	MANIFOLD	VALVE NO.	UPPER REEL	VALVE NO.	LOWER REEL	VALVE NO.	DEFINITE	DEFICIENT	VALVE POSITION		REMARKS
																O - OPEN	X - CLOSED	
5	DISCHARGE UPPER REEL	2,3	T	CAP	CAP	O	X	O	X									
	SLURRY LOWER REEL	2,3	T	CAP	CAP	O	O	X	X									

Follow operation No. 5 of the STARTING PROCEDURE instruction plate.

2

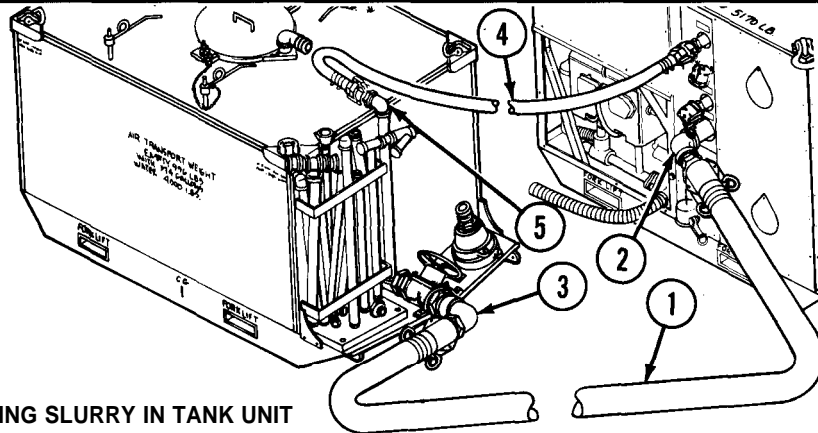

AGITATING SLURRY IN TANK UNIT

- a. Make sure one end of suction hose (1) is connected to the pump unit (2) and the other end is connected to the tank drain valve (3) if not already connected.

CAUTION

To ensure that VALVE NO. 1 is completely closed, check to see that the slurry has flooded back into the tank unit as indicated by the tank liquid level indicator (approximately 317 gallons).

- b. Close VALVE NO. 1 with the pump unit still operating.

CAUTION

The agitator-blender hose will contain slurry. Clean this hose before storing it on the tank unit.

NOTE

If only one discharge hose is to be used for spraying slurry, agitation of the slurry in the tank may continue. Open VALVE NO. 3 to the upper discharge hose. If adequate pressure is maintained (105 psi), continue both agitation and discharge. If not, stop agitation.

- c. Disconnect the agitator-blender (4) hose from the pump unit. Cap the upper discharge pipe and disconnect the hose from the agitator pipe (5) on the tank unit.

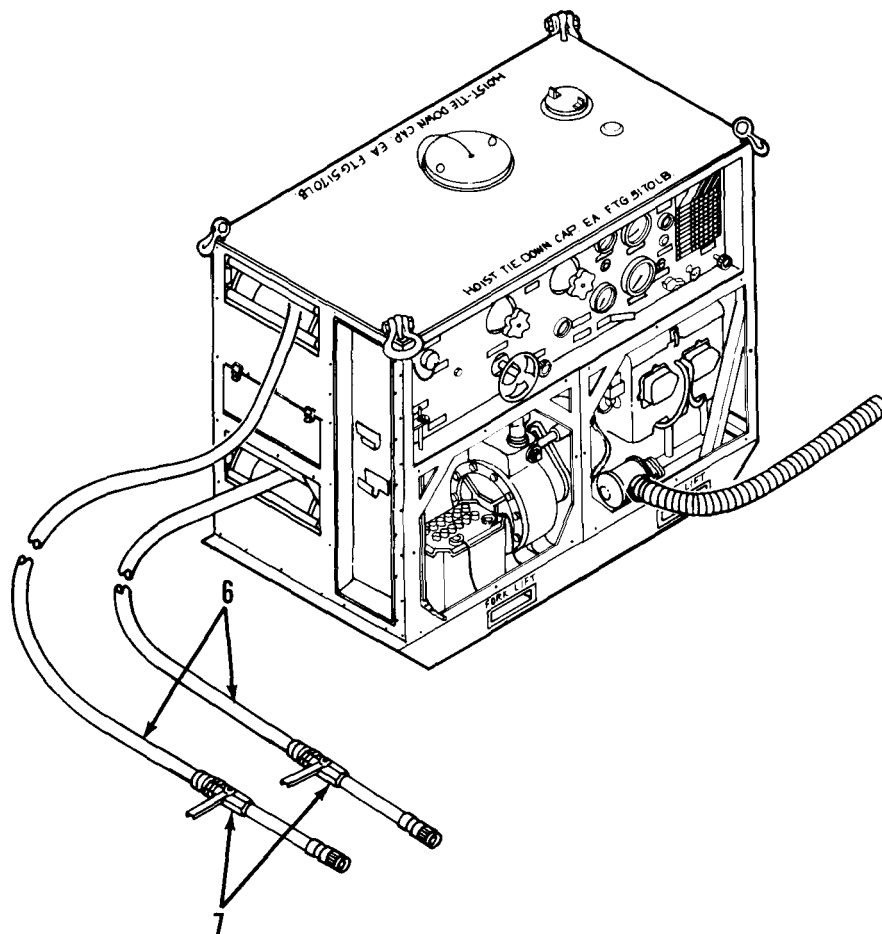
3

- a. Unreel the discharge hoses (6).
- b. Open VALVE NOS. 1,2,3 and gun assembly valves (7).

NOTE

The PRESSURE GAGE indication while spraying slurry may vary between 60 and 120 psi when the TACHOMETER is indicating 3,850 rpm.

- c. Adjust the orifice and deflector assembly to vary the spray pattern from stream to fine spray mist. The pump discharge pressure gage should indicate approximately 105 psi pressure when slurry is being sprayed.
- d. After the spraying mission is complete, flush, drain, clean, and store the apparatus according to procedure outlined in table 2-4

2-22. MIXING CHEMICALS OTHER THAN STB IN TANK.

Chemicals other than STB may be mixed in the tank. Below are the procedures for mixing four of those chemicals, sodium hydroxide (item 25, app D), sodium carbonate (soda ash) (item 24, app D), calcium hypochlorite (item 6, app D) and sodium hypochlorite. In general, chemicals which are water soluble and in powdered or granular form must be mixed in the tank using the tank hopper-blender and blender connection. Refer to FM 3-5 for additional information on decontaminants and decontaminating methods.

CAUTION

Never run anything other than clear water through the water heater. Always heat water to desired temperature before adding chemicals.

NOTE

Protective clothes and their use are contained in TM 10-277.

- a. Sodium Hydroxide (item 25, app D).

WARNING

When mixing, blending, or spraying sodium hydroxide solution, personnel must wear full rubber protective clothing, gloves, boots, and mask. Avoid contact with the skin or eyes and avoid breathing the dust.

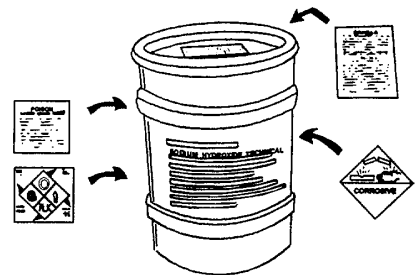

NOTE

Sodium hydroxide, commonly called caustic soda (or lye), dissolves easily in water. When dissolved in water, caustic soda generates a considerable amount of heat. A solution of water and caustic soda will destroy G-agents on contact.

- a. Handling of sodium hydroxide. Use extreme caution and wear rubber protective clothing when handling sodium hydroxide as even a five percent solution will eat away woolen or cotton clothing.
- b. For fast decontamination, spray heated rather than cold solutions of this decontaminant. The heat hastens the neutralizing actions of the decontaminating agent. Sodium hydroxide is available in 100-pound drums.

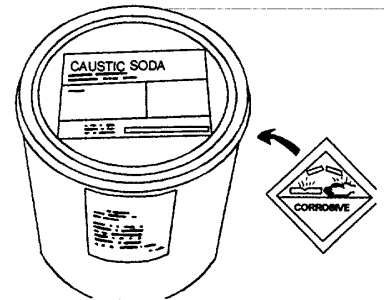

1

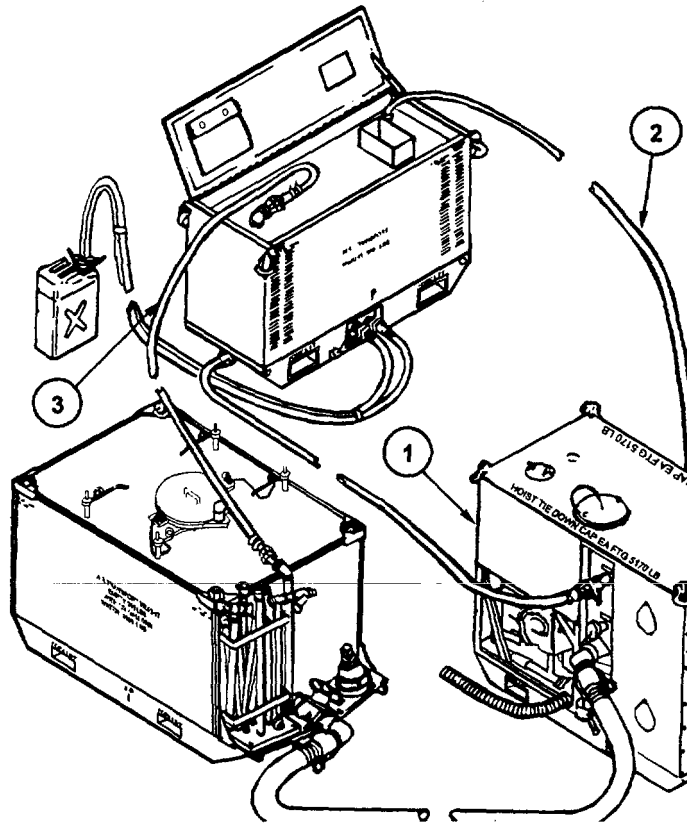

- a. Fill the tank unit assembly with 350 gallons of water. See paragraph 2-17 for hose, fuel, and electrical connections for heating water in tank. Heat the water to a temperature of 150°-170°F. After heating the water, place heater control switch to PURGE ON. Continue circulating water for 3 minutes through the heater with the heater control switch on PURGE ON.
- b. Place the HEATER RECEPTACLE AND SWITCH on pump unit (1) to OFF, disconnect the electrical power cable (2) and cap socket.

WARNING

- If it is necessary to disconnect the hoses with the water temperature at or above 100°F (38°C), exercise extreme care to prevent scalding.
- c. Either shut down the pump unit or close VALVE NO. 1. Disconnect the water hose (3) from the tank unit agitator pipe.

2-22. MIXING CHEMICALS OTHER THAN STB IN TANK(CONT).

a. *Sodium Hydroxide (item 25, app D) (Cont).*

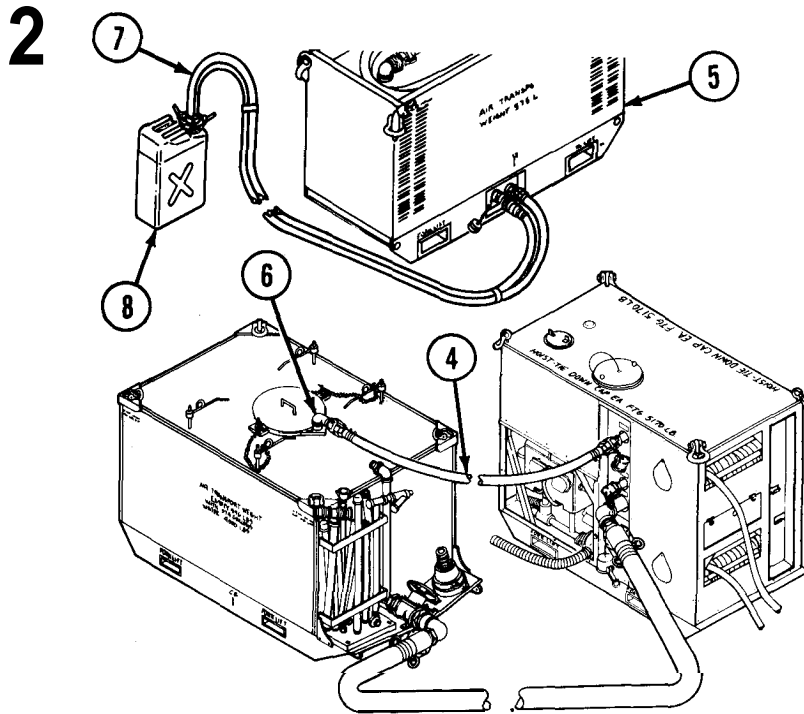

WARNING

If it is necessary to disconnect the hoses with the water temperature at or above 100° F (38° C), exercise extreme care to prevent scalding.

CAUTION

Hot water is present in the heater and will drain when blender hose is disconnected,

- a. Disconnect the blender (4) hose from water heater (5) bottom connection and connect it to the blender pipe (6) on the tank unit.

CAUTION

Insure that the water heater is cool before stowing the main electrical power cable and fuel and water hoses in the storage compartment.

- b. Disconnect the fuel hose (7) from the water heater (5) and the fuel supply (8). After the water heater has cooled, stow the fuel line, water hose, and electrical cable in the water heater storage compartment. Cap fuel supply and return line connections. Restart the pump unit or open VALVE NO. 1.

3

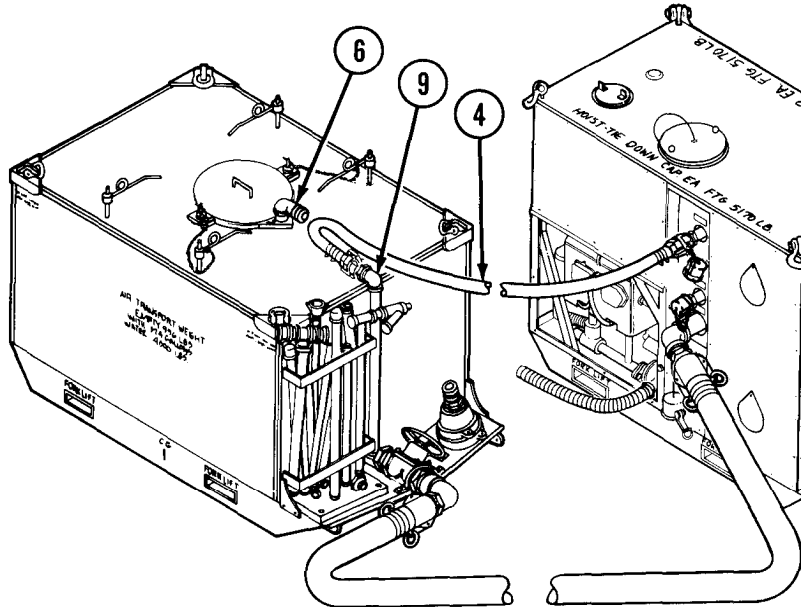

Blend 175 pounds (1-3/4 drums) of caustic soda to the 350 gallons of water (1/2 lb of sodium hydroxide to 1 gal of water) through the hopper-blender. Keep the caustic soda moving through the hopper-blender by constant stirring. Blending will require 35 to 40 minutes.

NOTE

If mixture is not used immediately, agitate until used. It must be agitated (through the agitation connection) for five minutes before using.

If agitation is required, close VALVE NO. 1, disconnect the agitator-blender hose (4) from the blender pipe (6), and attach it to the agitator pipe (9) on the tank unit.

b. Sodium Hypochlorite.

Sodium hypochlorite may be produced by mixing calcium hypochlorite (HTH) (item 6, app D) and sodium carbonate (soda ash) (item 24, app D) in the tank unit. The mixture produces sodium hypochlorite and a solid form of calcium carbonate. The particles of calcium carbonate must be kept in solution by agitation of the mixture.

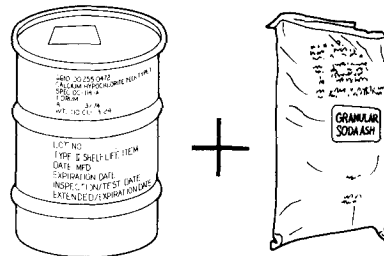

2-22. MIXING CHEMICALS OTHER THAN STB IN TANK (CONT).

b. Sodium Hypochlorite (Cont).

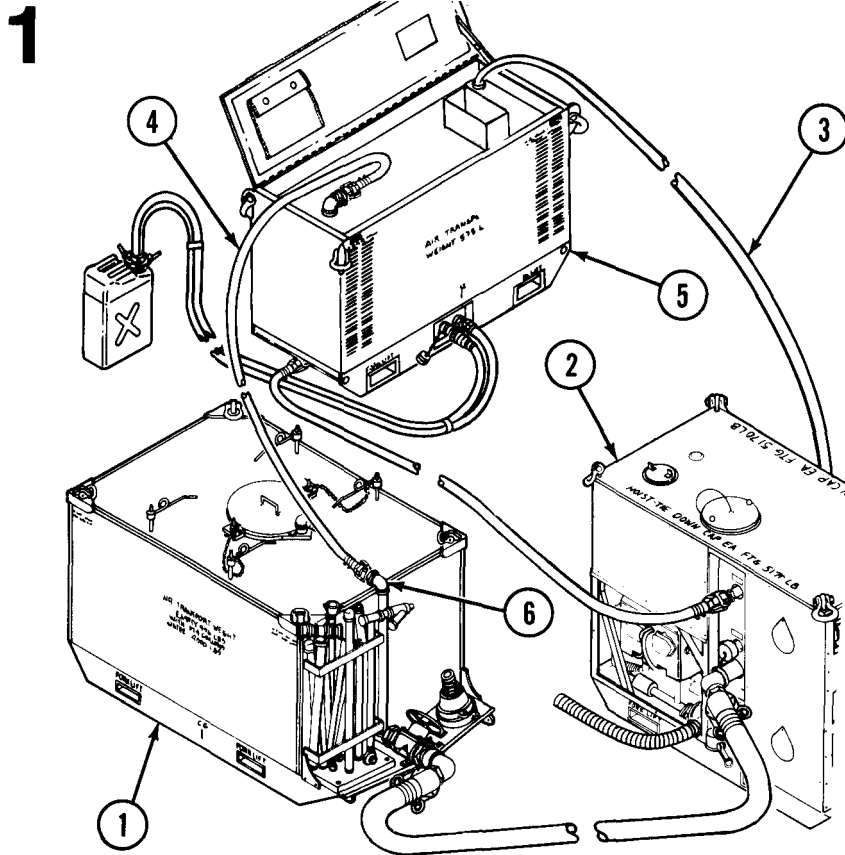

- a. Fill the tank unit (1) with 350 gallons of water. See paragraph 2-17 for hose, fuel, and electrical connections for heating water in tank. Heat the water to an indicated temperature of 150°-175° F. After heating the water, place heater control switch to PURGE ON. Continue circulating water for 3 minutes through the heater with the heater control switch on PURGE ON.
- b. Place the HEATER RECEPTACLE AND SWITCH on pump unit (2) to OFF and then disconnect the electrical power cable (3) and cap the socket.

WARNING

If it is necessary to disconnect the hoses with the water temperature at or above 100° F (38° C), exercise extreme care to prevent scalding.

- c. Either shut down the pump unit (2) or close VALVE NO. 1. Disconnect the water hose (4) from the tank unit agitator pipe (6).

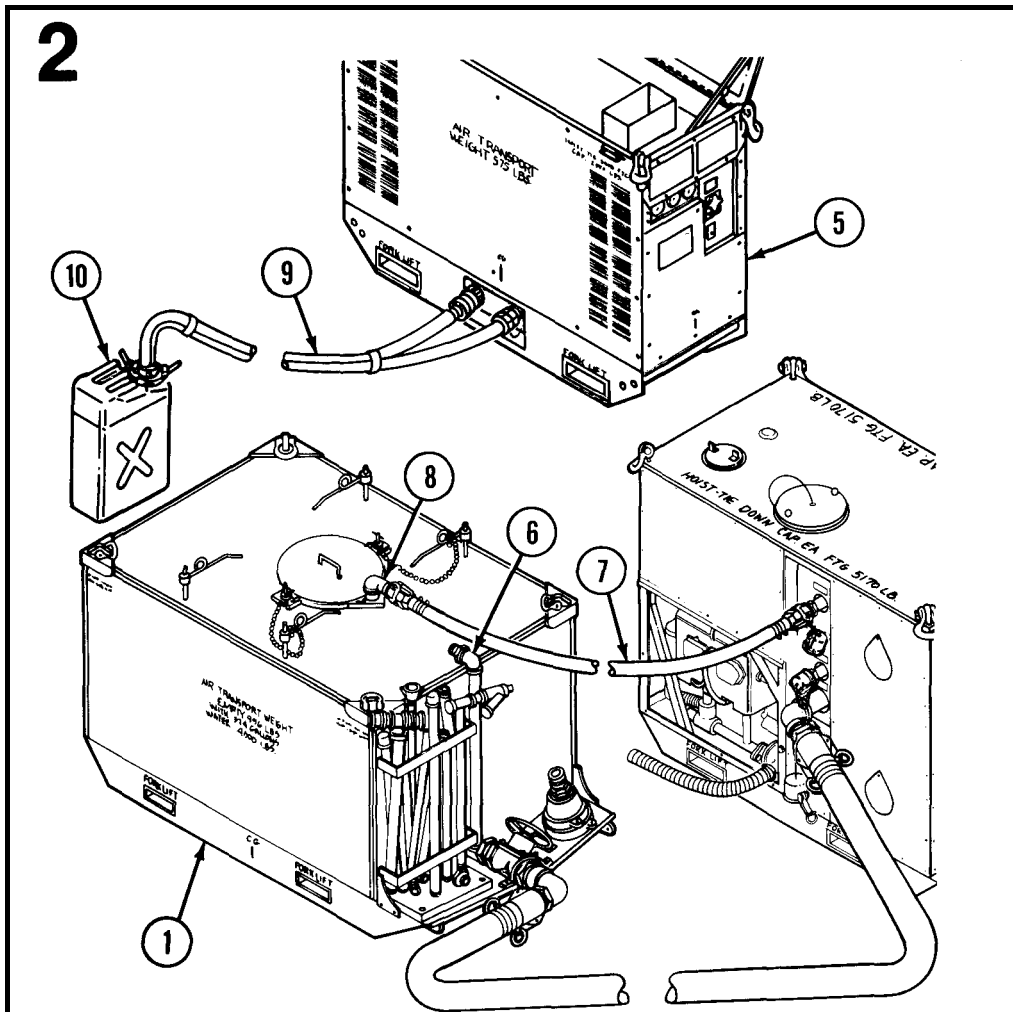

CAUTION

Hot water is present in the heater and will drain when blender hose is disconnected.

- a. Disconnect the blender hose (7) from the water heater (5) bottom connection and connect it to the blender pipe (8) on the tank unit (1).

CAUTION

Insure that the water heater is cool before stowing the main electrical power cable and fuel and water hoses in the storage compartment.

- b. Disconnect the fuel hose (9) from the water heater and the fuel supply (10). After the water heater has cooled, stow the fuel line, water hose, and electrical cable in the water heater storage compartment. Cap fuel supply and return connections. Restart the pump or open VALVE NO. 1.

2-22. MIXING CHEMICALS OTHER THAN STB IN TANK (CONT).

3

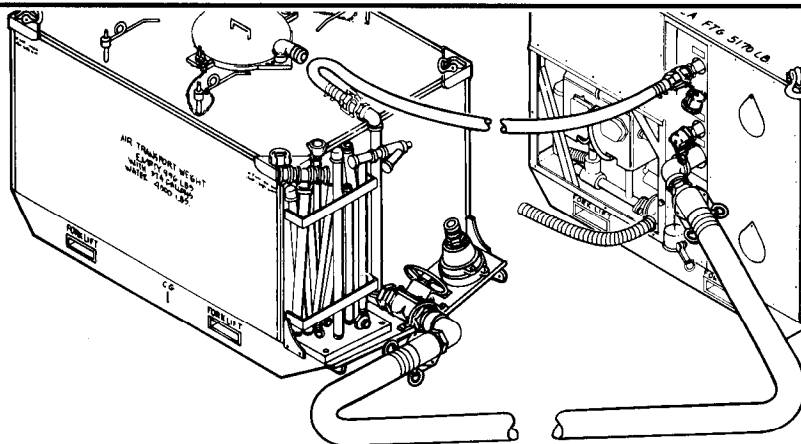

Add 175 pounds of calcium hypochlorite (1 / 2 lb per 1 gal of water) at a slow and steady rate. Add 250 pounds of sodium carbonate. It must be used immediately. If it is not, it must be agitated until used. Agitate for at least three minutes before using.

NOTE

If mixture is not used immediately, agitate until used. It must be agitated (through the agitation connection) for five minutes before using.

If agitation is required, close VALVE NO. 1, disconnect the agitator-blender hose (7) from the blender pipe (8), and attach it to the agitator pipe (6) on the tank unit.

c. Sodium Carbonate (item 24, app D).

NOTE

Sodium carbonate is commonly called soda ash, sal soda, washing soda, or laundry soda. The commercial grades may contain large amounts of sodium bicarbonate (baking soda). A sodium carbonate mixture does not neutralize blister agents or V-agents as readily as caustic soda or calcium hypochlorite. A hot or cold soda ash solution is effective on G-agents. Sodium carbonate is not as toxic as other decontaminants. However, crew members handling and preparing the solution should wear protective masks and gloves to guard against heavy clouds of powder.

Sodium carbonate is available in 100 pound bags.

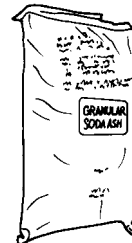

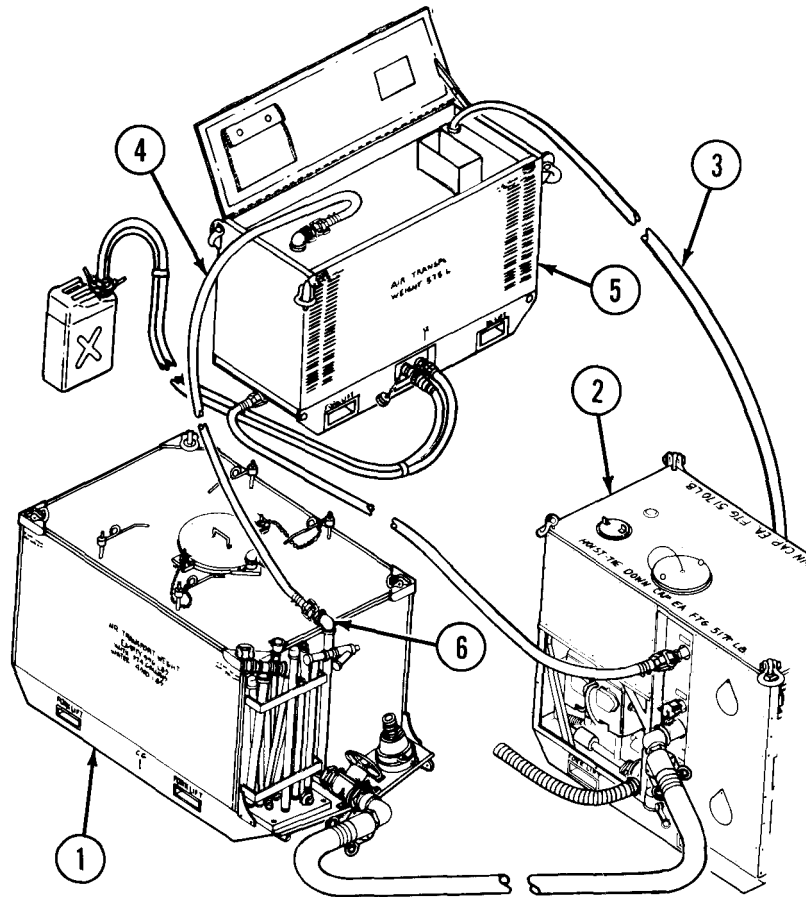
1

- a. Fill the tank unit (1) with 400 gallons of water. See paragraph 2-17 for hose, fuel, and electrical connections for heating water in tank. Heat the water to an indicated temperature of 75°F. After heating the water, place heater control switch to PURGE ON. Continue circulating water for 3 minutes through the heater with the heater control switch on PURGE ON.
- b. Place the HEATER RECEPTACLE AND SWITCH on pump unit (2) to OFF and then disconnect the electrical power cable (3) and cap the socket.

WARNING

If it is necessary to disconnect the hoses with the water temperature at or above 100° F (38 °C), exercise extreme care to prevent scalding.

- c. Either shut down the pump unit (2) or close VALVE NO. 1. Disconnect the water hose (4) from the tank unit agitator pipe (6).

2-22. MIXING CHEMICALS OTHER THAN STB IN TANK (CONT).

c. Sodium Carbonate (item 24, app D) (Cont).

2

CAUTION

Hot water is present in the heater and will drain when blender hose is disconnected.

a. Disconnect the blender hose (7) from the water heater (5) bottom connection and connect it to the blender pipe (8) on the tank unit (1).

CAUTION

Insure that the water heater is cool before stowing the main electrical power cable and fuel and water hoses in the storage compartment.

b. Disconnect the fuel hose (9) from the water heater (5) and the fuel supply (10). After the water heater has cooled, stow the fuel line, water hose and electrical cable in the water heater storage compartment. Cap fuel supply and return lines. Restart the pump unit or open VALVE NO. 1.

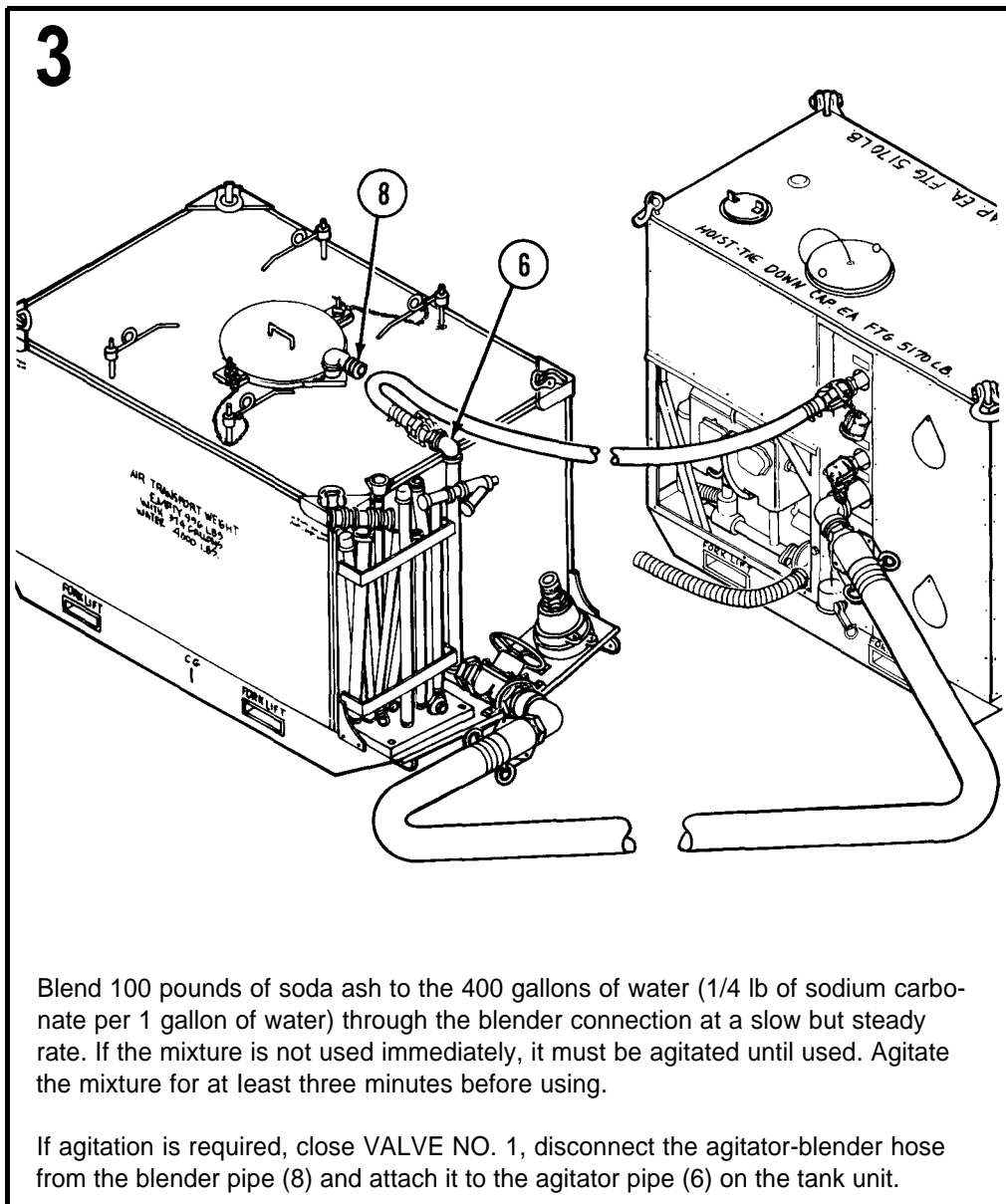

2-22. MIXING CHEMICALS OTHER THAN STB IN TANK (CONT).

d. *Calcium Hypochlorite (item 6, app D).*

WARNING

Calcium hypochlorite will destroy clothing, has a toxic vapor, and will burn the skin.

CAUTION

Calcium hypochlorite (HTH) is highly corrosive. Its use with the decontaminating apparatus may shorten its useful life. HTH should not be used except in an emergency when STB is not available.



NOTE

Calcium hypochlorite is commonly known as high-test hypochlorite (HTH) or high-test bleach (HTB). This compound contains a higher percentage of chlorine than STB decontaminating agent and is more corrosive. Crew members must wear a full set of rubber protective clothing when handling calcium hypochlorite. Hot or cold calcium hypochlorite is effective on the same agents as STB decontaminating agent. Clean equipment thoroughly after it has been used to spray calcium hypochlorite; flush with large amounts of water. Calcium hypochlorite is available in both 25 pound and 100 pound drums.

Protective clothes and their use are contained in TM 10-277.

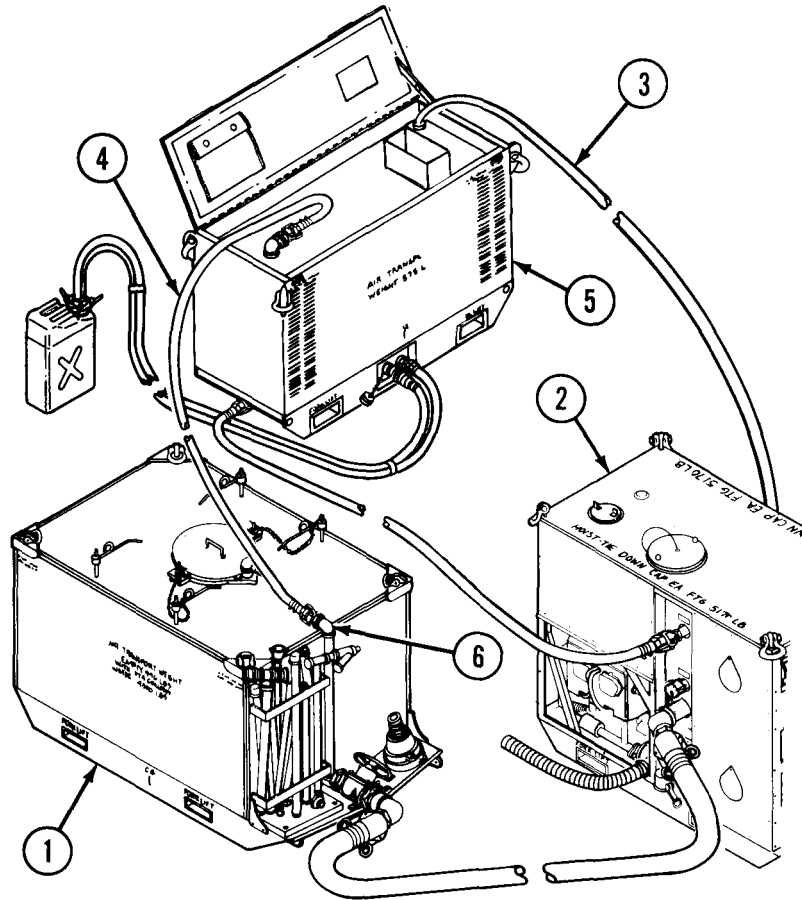
1

- a. Fill the tank unit (1) with 350 gallons of water. See paragraph 2-17 for hose, fuel, and electrical connections for heating water in tank. Heat water to an indicated temperature of 150°-175° F. After heating the water, place heater control switch to PURGE ON. Continue circulating water for 3 minutes through the heater with the heater control switch on PURGE ON.
- b. Place the HEATER RECEPTACLE AND SWITCH on pump unit (2) to OFF, disconnect the electrical power cable (3), and cap the socket.

WARNING

If it is necessary to disconnect the hoses with the water temperature at or above 100° F (38 °), exercise extreme care to prevent scalding.

- c. Either shut down the pump unit (2) or close VALVE NO. 1. Disconnect the water hose (4) from the tank unit agitator pipe (6).

2-22. MIXING CHEMICALS OTHER THAN STB IN TANK (CONT).

d. Calcium Hypochlorite (item 6, app D) (Cont).

2

CAUTION

Hot water is present in the heater and will drain when blender hose is disconnected.

a. Disconnect the blender hose (7) from the water heater (5) bottom connection and connect it to the blender pipe (8) on the tank unit (1).

CAUTION

Insure that the water heater is cool before stowing the main electrical power cable and fuel and water hoses in the storage compartment.

b. Disconnect the fuel hose (9) from the water heater (5) and the fuel supply (10) (after the water heater has cooled) and stow it in the water heater storage compartment. Cap fuel supply and return lines. Restart pump unit or open VALVE NO. 1.

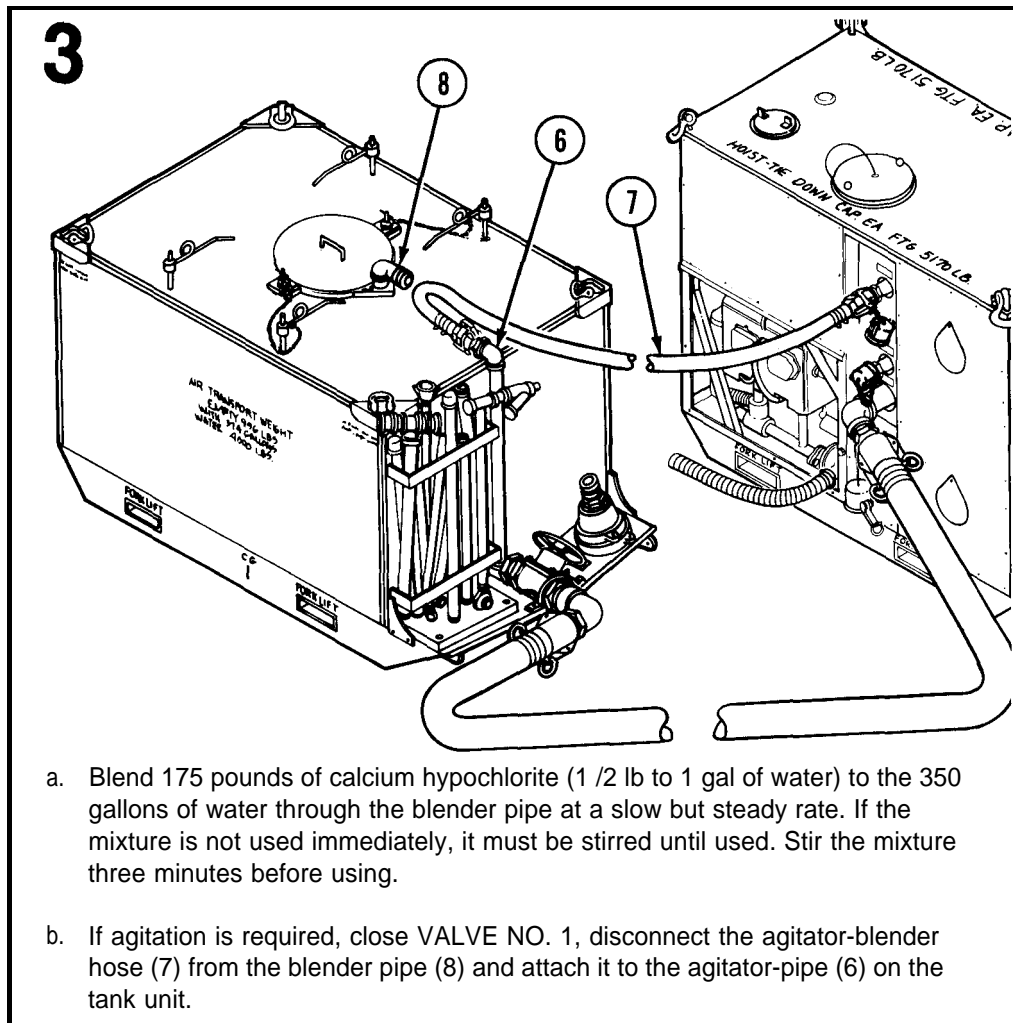

2-23. MIXING WATER AND LIQUID CHEMICALS USING THE PRIME-DETERGENT TANK.

Concentrated liquids which dissolve readily in water may be mixed with water in the pump cavity by using the prime-detergent tank. The chemical to be mixed with water is placed in the prime-detergent tank after the pump unit has been primed. It is metered into the pump cavity using VALVE NO. 4. The water and chemical mixture is then discharged through the discharge hoses. Water should not be discharged to the tank unit during metering of liquid chemicals. The procedures for using two of the more common concentrated liquids, liquid detergent (item 8, app D) and fire extinguishing foam forming liquid (item 12, app D) for petroleum fires are given below.

- a. *Liquid Detergent (item 8, app D).*

1

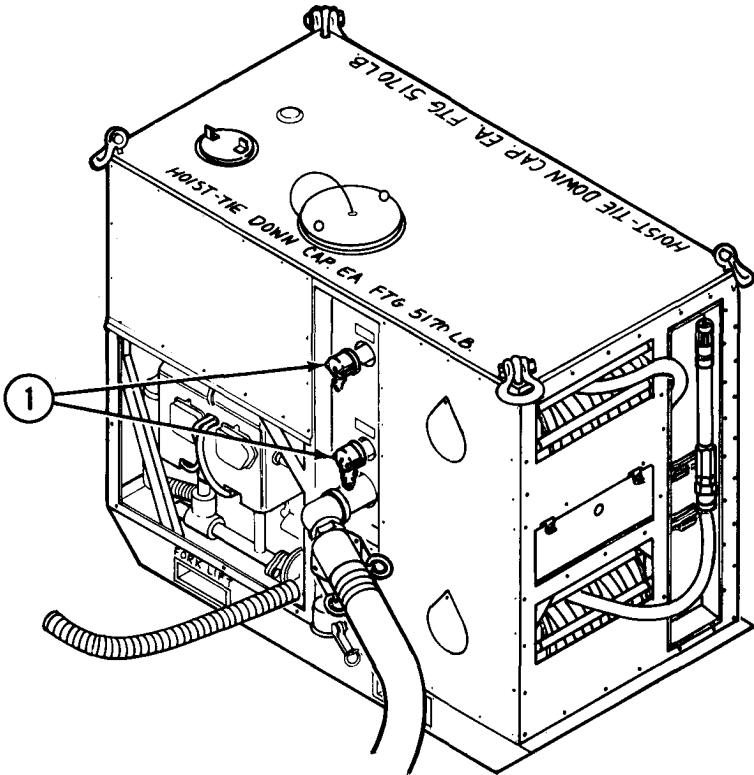

a. Heat the water in the tank to approximately 90°F (para 2-17).

CAUTION

Hot water is present in the heater and will drain when blender hose is disconnected.

b. Disconnect the water heater. Cap both discharge pipes (1) on the connector panel immediately. Do not allow the pump to drain.

a. *Liquid Detergent (item 8, app D) (Cont).*

2

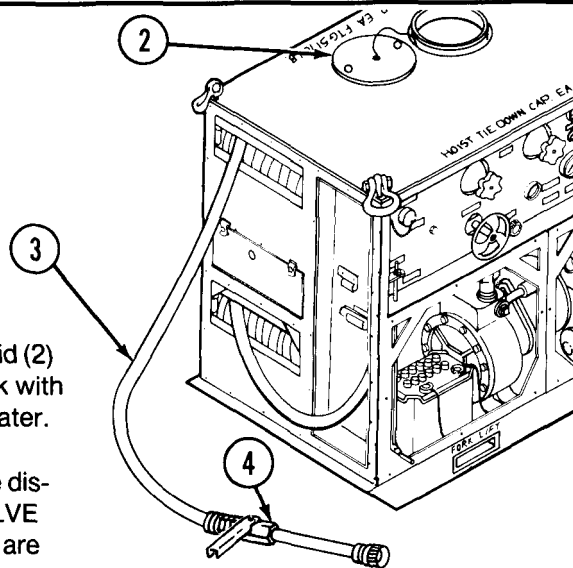

- a. Remove prime detergent tank lid (2) and fill the prime-detergent tank with 1 pint of liquid detergent and water.
- b. Open VALVE NO. 1. Unreel the discharge hoses (3) and open VALVE NOS. 2 and 3 if both hose reels are to be used.
- c. Start the pump unit. Open VALVE NO. 4 slightly to add the detergent mixture to the water.
- d. Open valve (4) on the gun assembly and begin spraying liquid detergent mixture.
- e. After spraying mission is complete, clean and store the apparatus according to applicable procedure listed in table 2-4.

b. *Fire Extinguishing Foam (item 12, app D) for Petroleum Fires.*

1

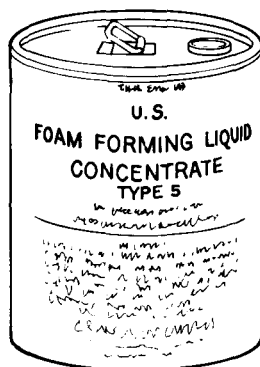

- a. Prime and start the pump unit (see para 2-11).
- b. Fill the prime detergent tank with 5 gallons of foam forming liquid concentrate.

2-23. MIXING WATER AND LIQUID CHEMICALS USING THE PRIME-DETERGENT TANK (CONT).

b. *Fire Extinguishing Foam (item 12, app D) (Cont).*

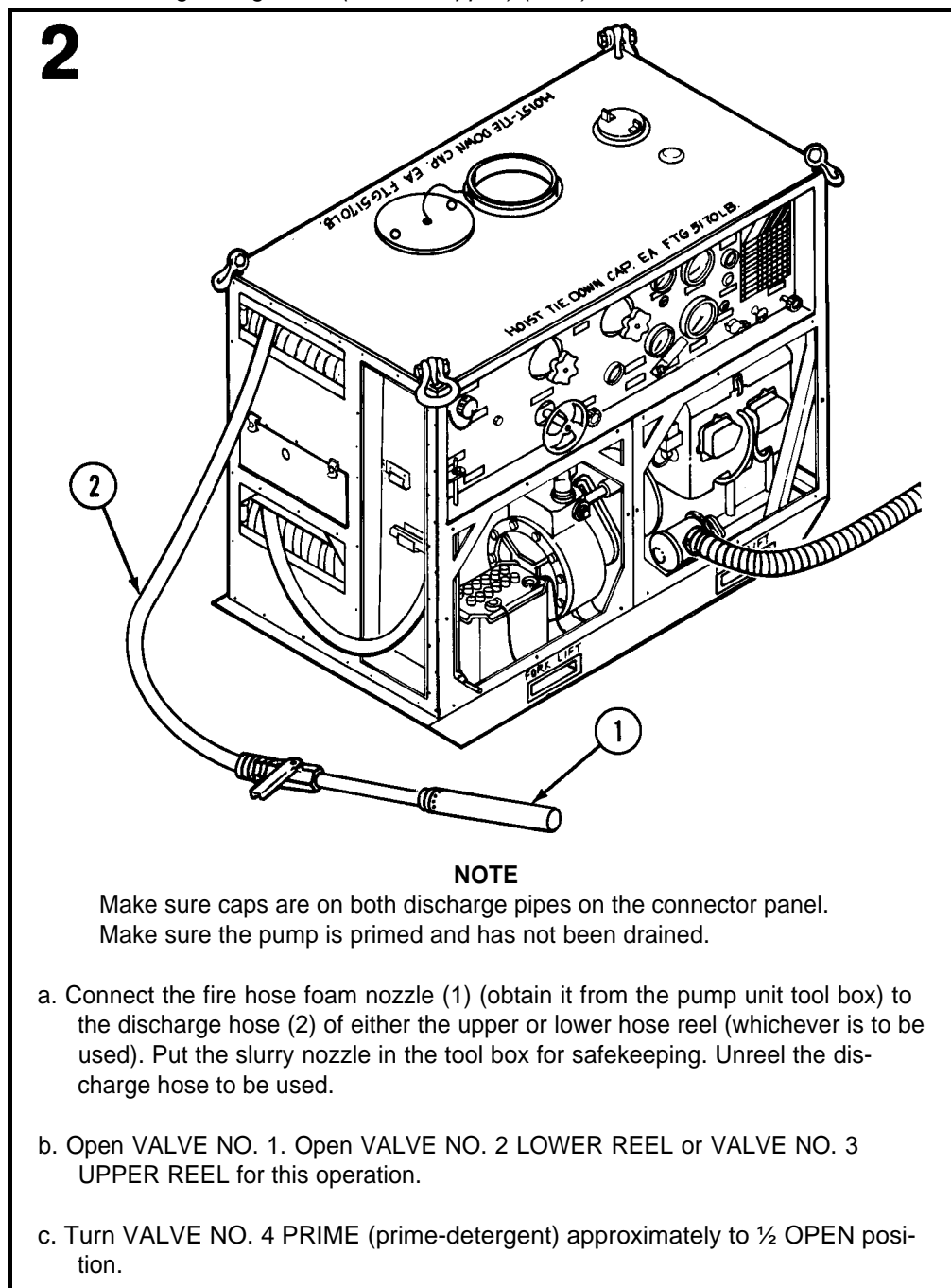

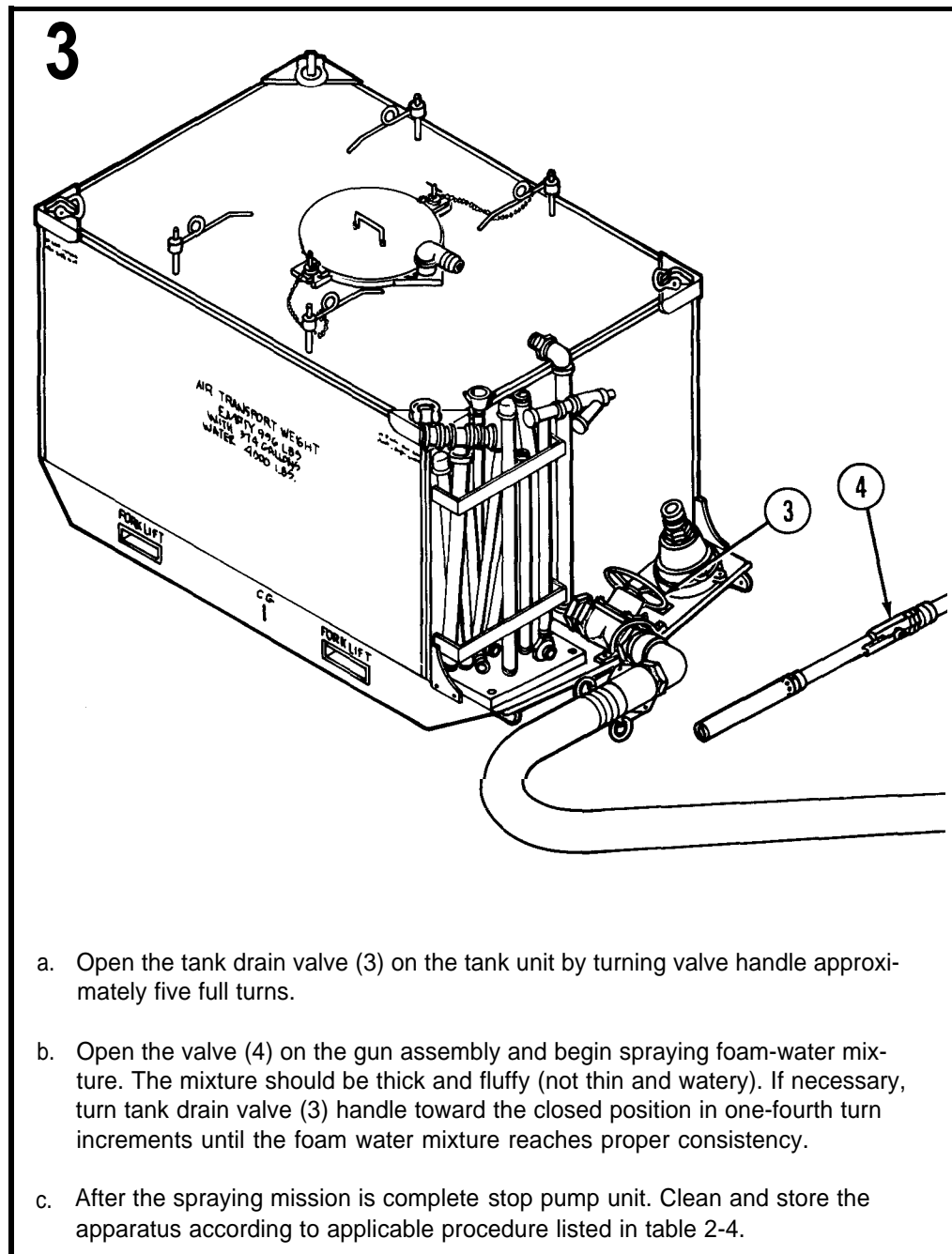

3

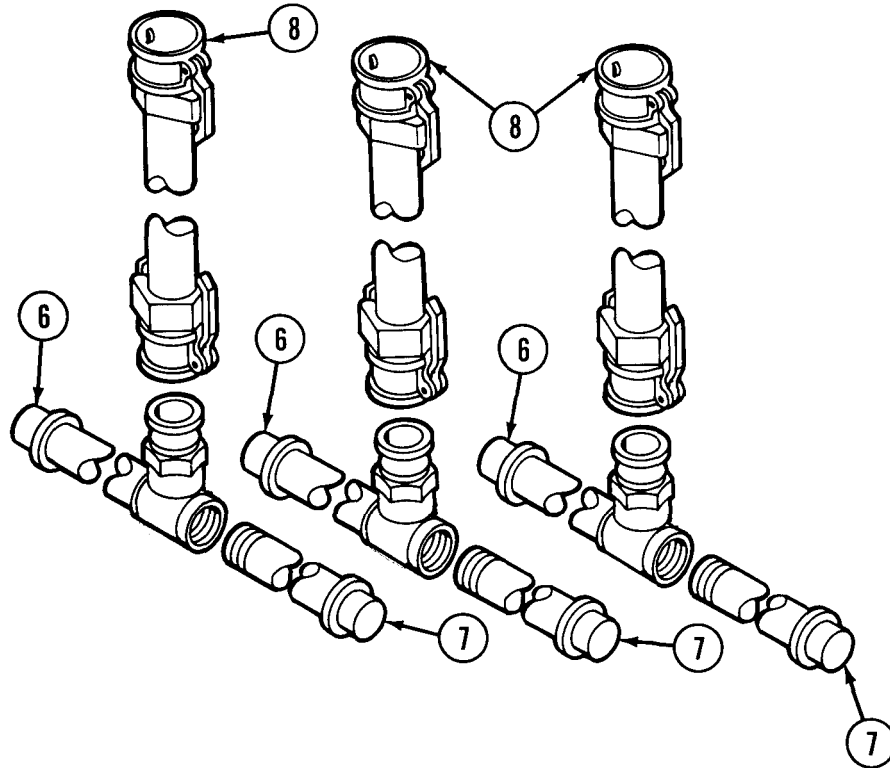

- a. Assemble three horizontal supports (6) to three horizontal supports (7), as illustrated.
- b. Connect three lower vertical supports (8) to three horizontal supports, as illustrated.

2-24. SHOWERING (CONT).

4

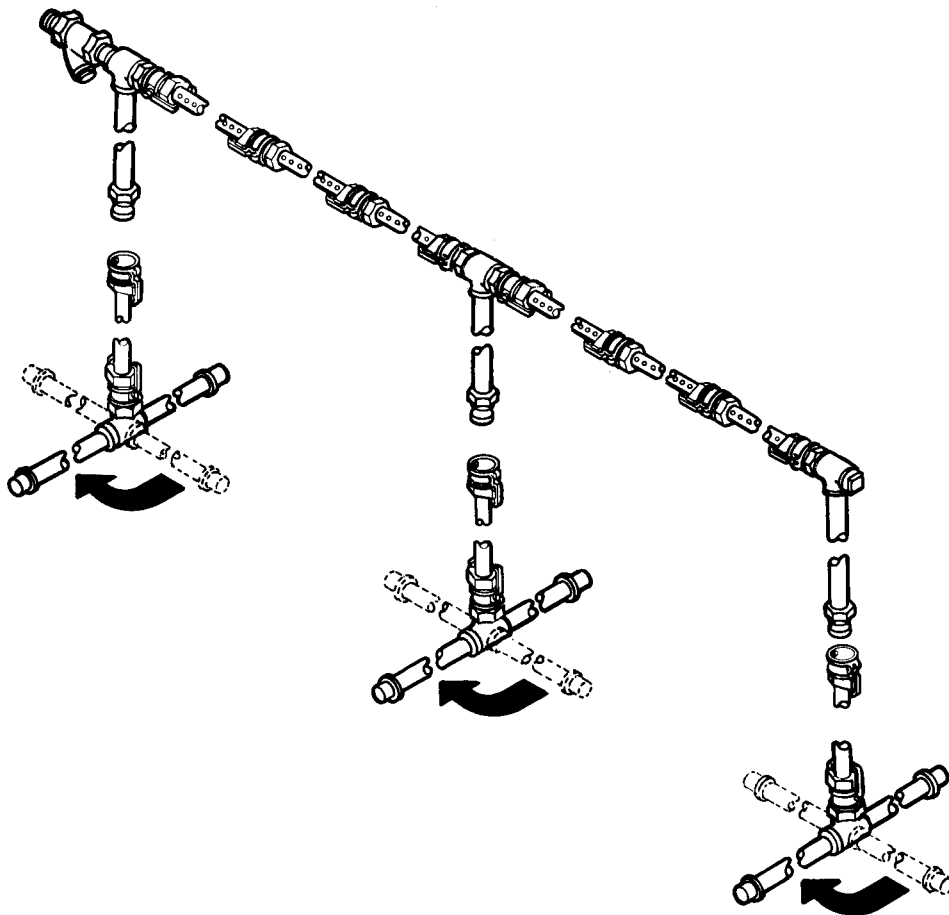

- a. Connect three lower sections to the upper section. Stand upright and rotate three horizontal supports 90°, as illustrated.
- b. Disconnect the gun assembly and adapter from the upper discharge hose. Connect the discharge hose to the shower. Inspect to see that the shower holes are aligned properly.

5

OPERATION NO	OPERATION	PREVIOUS OPERATION REQUIRED	S—SUCTION HOSE TO SOURCE	T—TANK DISCHARGE CONNECTION	VALVE #1 CONNECTION	VALVE #2 MANIFOLD	VALVE #3 LOWER REEL	VALVE #4 UPPER REEL	PRIME DETERGENT	VALVE POSITION		REMARKS
										O—OPEN	X—CLOSED	
7	DISCHARGE UPPER REEL	1	S/T	* ON	** ON	X	X	O	X			*FROM HEATER **TO HEATER
	HOT WATER LOWER REEL	1	S/T	* ON	** ON	X	O	X	X			*FROM HEATER **TO HEATER

Follow operation number 7 on the STARTING PROCEDURE instruction plate.

- a. Connect the suction hose to the pump unit. Depending on mode of operation, connect the foot valve to the other end of the suction hose, or connect the suction hose to the tank drain valve.
- b. Make other connections necessary for mode of operation.
- c. Prime the pump and start the pump unit (see para 2-11).
- d. After the water heater has filled with water, start the heater (see para 2-17).
- e. After water is heated, open VALVE NOS. 1 and 3.

2-24. SHOWERING (CONT).

6

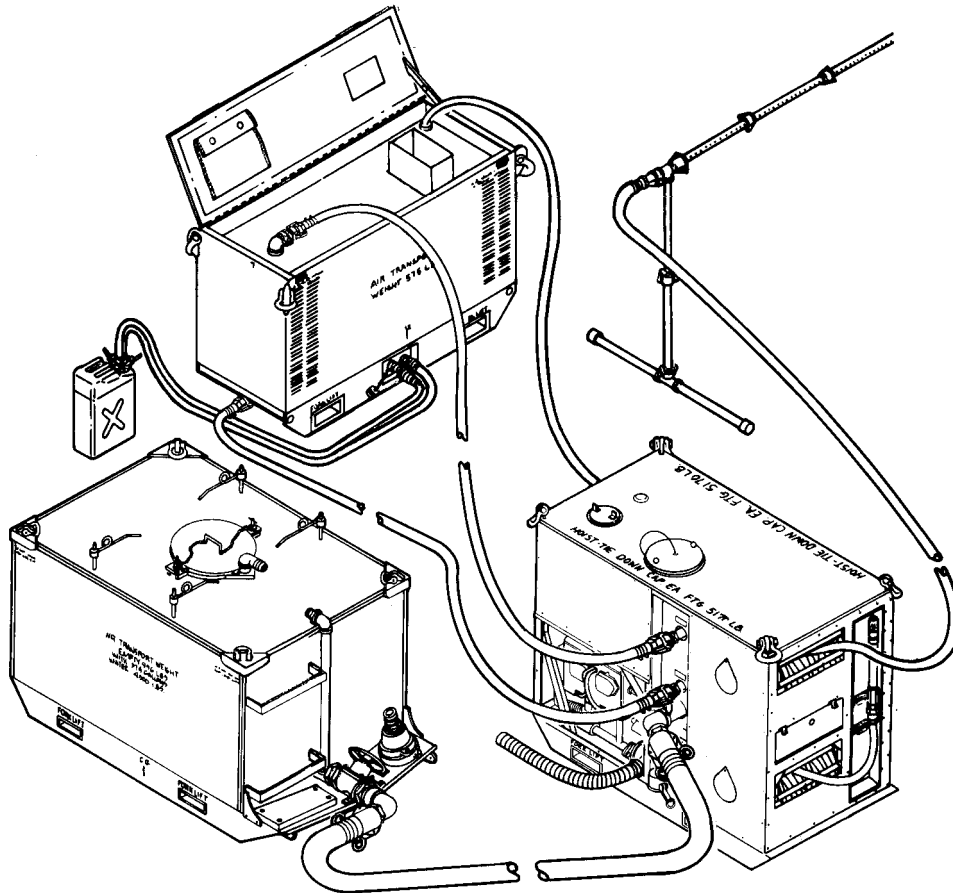

Showering personnel with water from the tank.

7

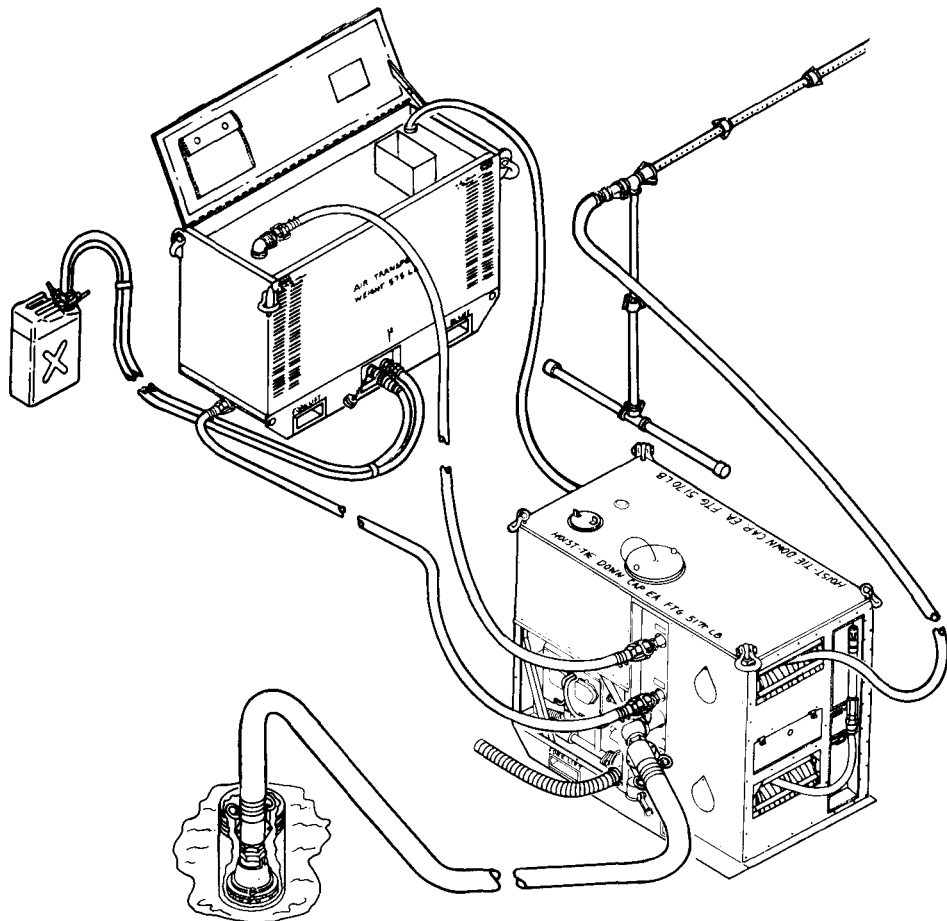

Showering personnel with water drawn from a natural source.

2-24. SHOWERING (CONT).

8

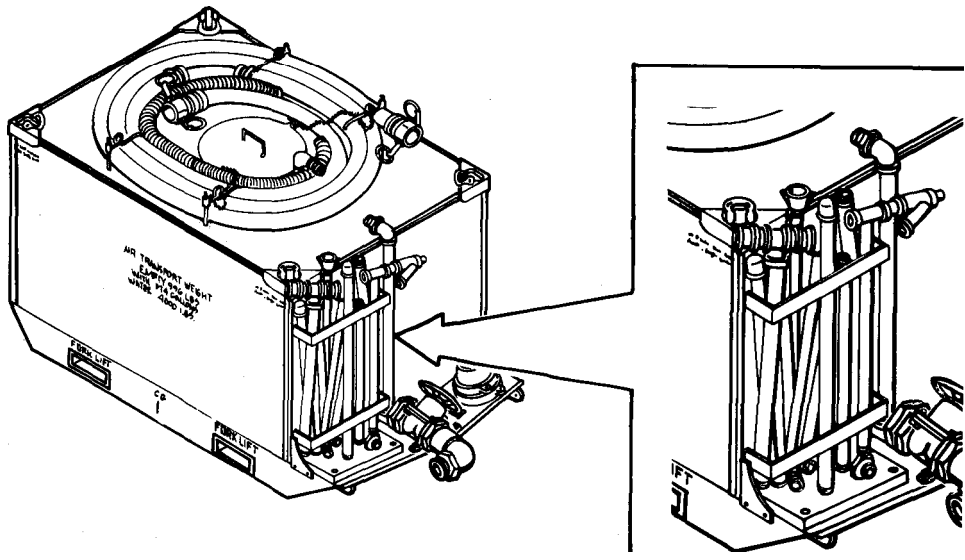

- a. When mission incomplete, shutdown the water heater (see para 2-18).
- b. After the water heater is shut down, stop the pump unit (see para 2-12).
- c. Disassemble the personnel shower assembly.
- d. When disassembling the personnel shower assembly, avoid burring pipes or fittings. Stow the shower assembly in the brackets on the tank unit assembly. The sections with solid caps should be stowed with the caps up to keep water from building up in the pipe.
- e. Clean and store the apparatus according to the applicable procedure listed in table 2-4.

CAUTION

Always position six horizontal supports (pipes with solid caps) in the brackets so that the pipe caps are on top. Otherwise, water can be trapped in the pipe causing rust or the water can freeze and break the pipe.

2-24.1 HEATING WATER IN THE TANK.

1

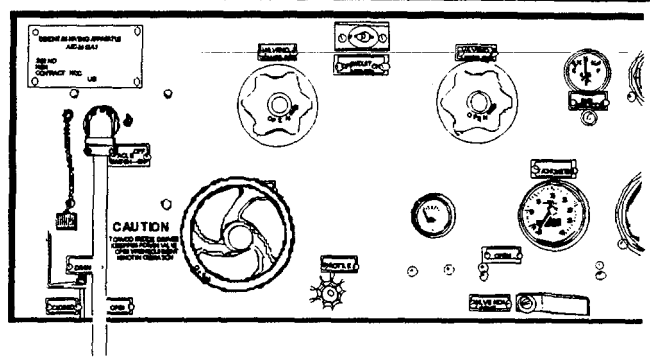

Close VALVE NOs. 1, 2, and 3.

2

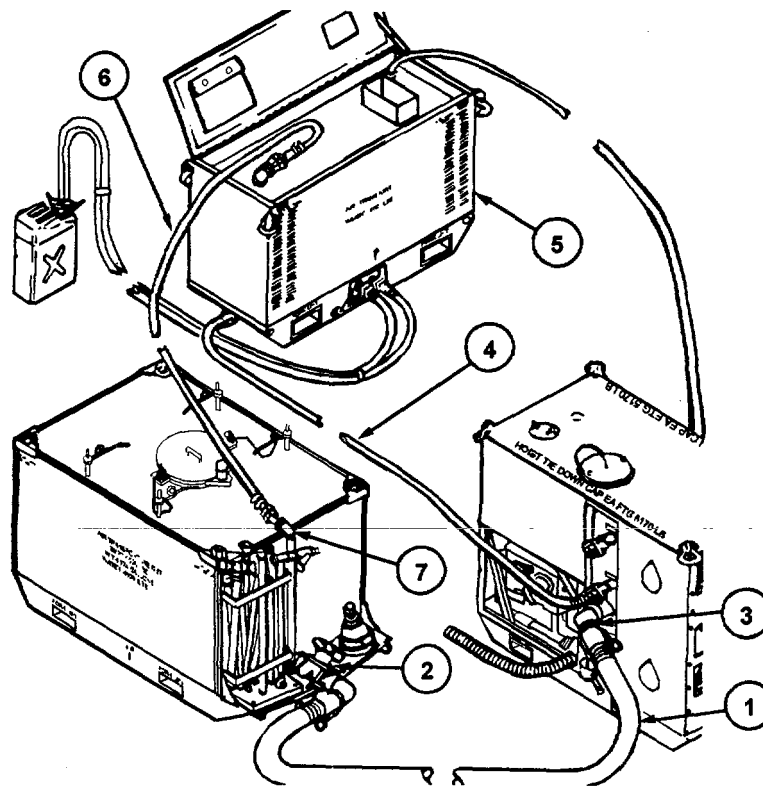

- a. Connect one end of suction hose (1) to tank unit drain valve (2) and other end to suction connection on pump unit (3). Open tank drain valve (2).
- b. Connect one end of blender hose (4) to bottom discharge connection on pump unit and other end to bottom connection on water heater (5).
- c. Connect free end of heater unit water hose (6) to agitator connection (7) on tank unit and other end to upper connection on water heater.

2-24.1 HEATING WATER IN THE TANK (CONT).

3

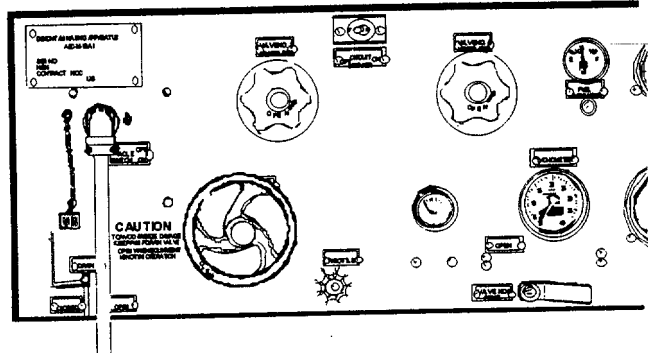

- a. Prime and start the pump unit (see para 2-11).
- b. Start and run the water heater according to paragraph 2-17.
- c. Hot water may be dispersed through upper and/or lower reels and out discharge hose(s), if VALVE NOs. 2 and/or 3 are opened.
- d. After the mission is complete, stop the water heater (see para 2-18).
- e. Stop the pump unit (see para 2-12).
- f. Clean and store the apparatus according to the applicable procedure listed in table 2-4.

2-25. PREPARATION FOR MOVEMENT.

See table 2-4.

Table 2-4. CLEANING AND STORAGE PROCEDURES AFTER A SPRAYING MISSION

Item No.	Expected Idle Time	Procedure
1	Less than 24 hours	<p>Start the pump unit. Flush the interior of the tank, agitator pipe, blender pipe, and prime-detergent tank with water. Unreel the discharge hoses from both hose reels and open the gun assembly valves. Stop the pump unit. Open VALVE NOS. 1,2,3, and 4, and the pump DRAIN valve. Drain the hoses. Close the orifice-and-deflector assemblies on both slurry nozzles. Reel the discharge hoses neatly on the hose reels. Stow the gun assemblies in their brackets. When the pump is drained, close VALVE NOS. 1,2,3, and 4. Leave the the pump DRAIN valve open. Install the hopper-blender cover. Disconnect and drain the suction hose. Install the blender hose inside the suction hose. Stow the suction hose and the blender hose on top of the tank unit. Close the tank drain valve after all water has drained from the tank unit. Install the foot valve assembly in the bracket on the tank unit skid. Drain the boiler of the water heater. Drain the fuel hose and the water hose; stow them in the storage compartment. Stow the exhaust extensions on the tank unit and lash them in place. Install the cover panels and dust cover over the pump unit.</p>
2	24 to 48 hours	<p>Drain the slurry from the tank unit. Clean the M12A1 decontaminating apparatus (item No. 1 above). Lubricate the pump by pouring 3 pints of special-preservative general-purpose lubricating oil (PL-M or PL-S) (items 19 or 20, app D) mixed with 3 gallons of water into the prime-detergent tank. Open VALVE NO. 4 and allow the oil-water mixture to run into the pump. Start the pump unit and operate it for 30 seconds. Stop the pump unit. Open the pump DRAIN valve and allow the oil-water mixture to run out. Check that prime-detergent tank is empty. Close valve NO. 4 and leave pump drain valve open.</p>

Table 2-4. CLEANING AND STORAGE PROCEDURES AFTER A SPRAYING MISSION (CONT)

Item No.	Expected Idle Time	Procedure
3	Over 48 hours	Drain (item No. 1 above) and clean (item No. 2 above) the M12A1 decontaminating apparatus. Wipe the exterior surfaces of the pump, piping, valves, and other metal parts with a cloth saturated in oil to retard corrosion. Wipe the generator, battery, engine housing, and fuel tank with a clean, dry cloth. Coat the battery terminals with GAA (item 16, app D). Inspect the water level of the battery cells. Install the cover panels and dust cover over the pump unit assembly.

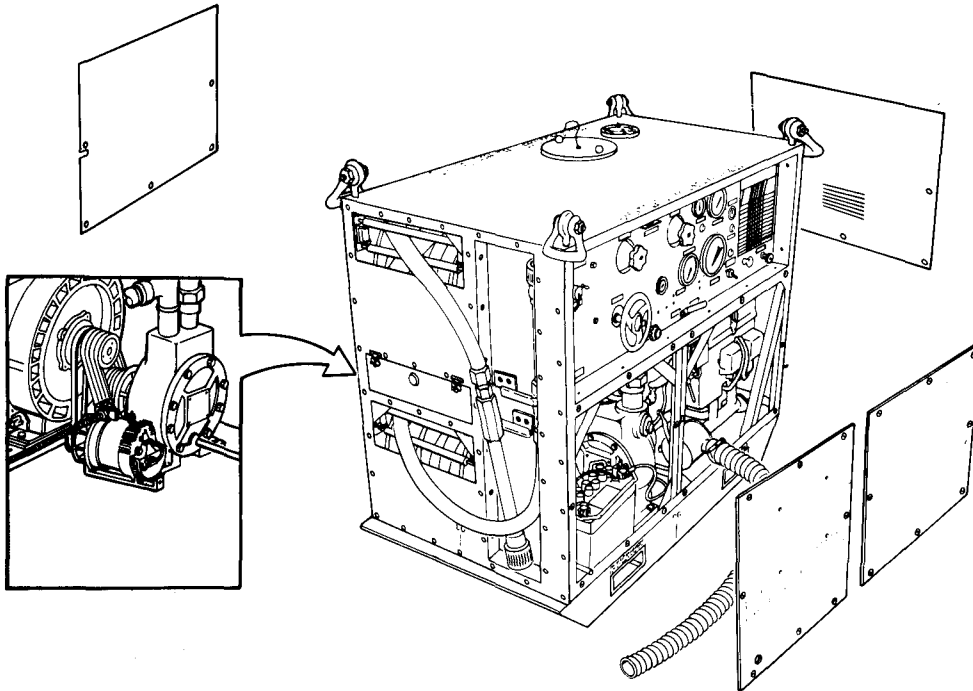

2-26. OPERATING INSTRUCTIONS ON DECALS AND INSTRUCTION PLATES.

The nameplate for the decontaminating apparatus and identification plates for valves, instruments, and controls are located on the control panel of the pump unit. A STARTING PROCEDURE plate shows valve positions and operating procedures. Nameplates are also located on the pump, generator regulator, and engine. The nameplate and identification plates for the water heater are located on the front of the water heater.

Table 2-5. OPERATING INSTRUCTIONS ON DECALS AND INSTRUCTION PLATES

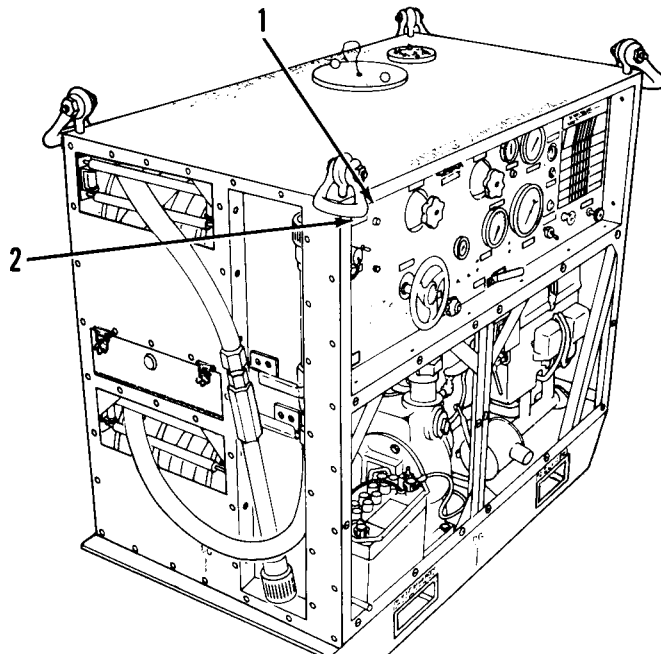

Pump Unit

Key	Plate										
1	M12A1 Decontaminating Apparatus Nameplate <div data-bbox="735 1159 1154 1342" style="border: 1px solid black; padding: 5px; margin: 10px auto; width: fit-content;"> <p style="text-align: center;">DECONTAMINATING APPARATUS ABC-M12A1 SERIAL NO. MSN 4230-00-926-9408 CONTRACT NO U.S.</p> </div>										
2	MWO Nameplate (typical) <div data-bbox="467 1410 1216 1768" style="border: 2px solid black; padding: 10px; margin: 10px auto; width: fit-content;"> <table border="1" style="width: 100%; border-collapse: collapse;"> <tr> <td style="padding: 5px;">SERIAL NO.</td> <td style="padding: 5px;">[REDACTED]</td> </tr> <tr> <td style="padding: 5px;">REPAIRED AT</td> <td style="padding: 5px;">DATE</td> </tr> <tr> <td style="padding: 5px;">MZ AD</td> <td style="padding: 5px;">[REDACTED]</td> </tr> <tr> <td style="padding: 5px;">MWO APPLIED</td> <td style="padding: 5px;">DATE</td> </tr> <tr> <td style="padding: 5px;">[REDACTED]</td> <td style="padding: 5px;">[REDACTED]</td> </tr> </table> </div>	SERIAL NO.	[REDACTED]	REPAIRED AT	DATE	MZ AD	[REDACTED]	MWO APPLIED	DATE	[REDACTED]	[REDACTED]
SERIAL NO.	[REDACTED]										
REPAIRED AT	DATE										
MZ AD	[REDACTED]										
MWO APPLIED	DATE										
[REDACTED]	[REDACTED]										

Table 2-5. OPERATING INSTRUCTIONS ON DECALS AND INSTRUCTION PLATES (CONT)

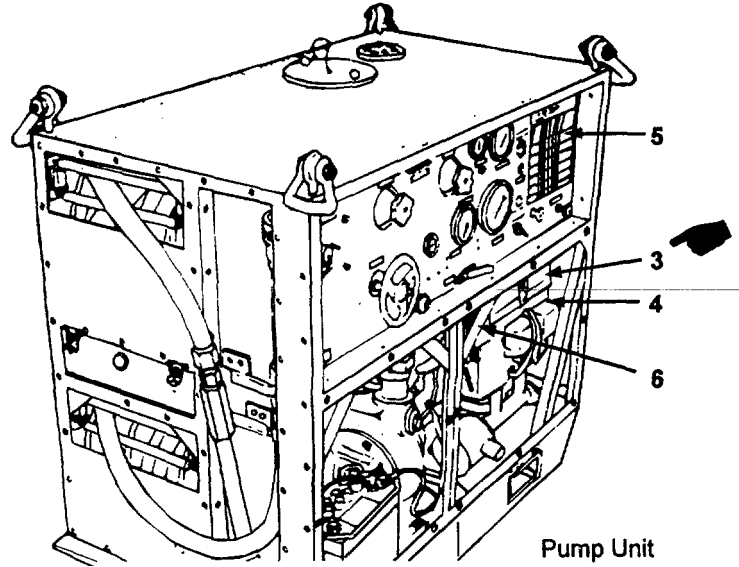

Key	Plate
3	<p>20 HP Engine Decal</p> <div data-bbox="917 1066 1182 1459" data-label="Image"> </div>
4	<p>Gasoline Engine Nameplate</p> <div data-bbox="820 1486 1136 1827" data-label="Image"> </div>

Key Plate

5 STARTING PROCEDURE Instruction Plate

STARTING PROCEDURE

CAUTION: Do not operate pump dry or when discharge pressure is below 60 p.s.i.g. Reduce engine speed to idle before turning off ignition. READ THE MANUAL

1. Check all valve settings before starting.
2. Open throttle about one-half to start.
3. Turn starting switch to start, and at the same time, depress oil pressure switch.
4. When engine starts, release start switch to run position but continue depressing oil pressure switch until oil pressure exceeds 20 p.s.i.g.; then release oil pressure switch.
5. Adjust throttle to 3850 R.P.M. (Tachometer reading)
6. Check all gages to insure proper operation.
7. Prime-Detergent Valve #4 must be closed when Prime-Detergent Tank is empty.

OPERATION NO	OPERATION	PREVIOUS OPERATION REQUIRED	SUCTION HOSE TO SOURCE	DISCHARGE CONNECTION UPPER	DISCHARGE CONNECTION LOWER	VALVE #1 MANIFOLD	VALVE #2 LOWER REEL	VALVE #3 UPPER REEL	VALVE #4 PRIME DETERGENT	VALVE POSITION		REMARKS
										O—OPEN	X—CLOSED	
1	PRIME DRY PUMP TURN ON FUEL SUPPLY START (SEE PROCEDURE)	—	S	ON	CAP	O	X	X	O			**TO TANK AGITATOR CONNECT ONE INCH HOSE **OPEN FOR 1 MINUTE BEFORE STARTING, THEN CLOSE TO HALFWAY FOR REMAINDER OF PRIME OPERATION (SEE 7 ABOVE)
2	FILL TANK WITH WATER	1	S	ON	CAP	O	X	X	X			*TO AGITATOR CONNECT ONE INCH HOSE
3	BLEND SLURRY	2	T	ON	CAP	O	X	X	X			*TO TANK BLENDER ADD ANTISET THEN ADD STB
4	AGITATE SLURRY	3	T	ON	CAP	O	X	X	X			*TO TANK AGITATOR
5	DISCHARGE UPPER REEL	2,3	T	CAP	CAP	O	X	O	X			
	SLURRY LOWER REEL	2,3	T	CAP	CAP	O	O	X	X			
6	DISCHARGE UPPER REEL	1	S/T	CAP	CAP	O	X	O	X			
	WATER LOWER REEL	1	S/T	CAP	CAP	O	O	X	X			
7	DISCHARGE UPPER REEL	1	S/T	ON	ON	X	X	O	X			*FROM HEATER **TO HEATER
	HOT WATER LOWER REEL	1	S/T	ON	ON	X	O	X	X			*FROM HEATER **TO HEATER
8	PUMP WATER ONLY TO HEATER OR OTHER	1	S/T	ON	CAP	O	X	X	X			*TO HEATER OR OTHER
9	DISCHARGE FOAM UPPER REEL	1	S/T	CAP	CAP	O	X	O	O			*ADJUST FOR PROPER BLEND
	OR DETERGENT LOWER REEL	1	S/T	CAP	CAP	O	O	X	O			*ADJUST FOR PROPER BLEND
10	FLUSH SYSTEM	1	S	OPEN TANK DRAIN AND FLUSH TANK THOROUGHLY, THEN OPEN PUMP DRAIN AND FLUSH HOSE REELS AND DISCHARGE CONNECTIONS (SEE MANUAL)								
11	SHUTDOWN PROCEDURE	REDUCE ENGINE SPEED TO IDLE, SHUT OFF IGNITION AND FUEL SUPPLY, CAP ALL PIPES, AND CLOSE ALL VALVES INCLUDING DRAINS.										

6 Engine Fuse Nameplate

**TO REMOVE FUSE :
LOOSEN TWO NUTS
AND LIFT COVER**

Table 2-5. OPERATING INSTRUCTIONS ON DECALS AND INSTRUCTION PLATES (CONT).

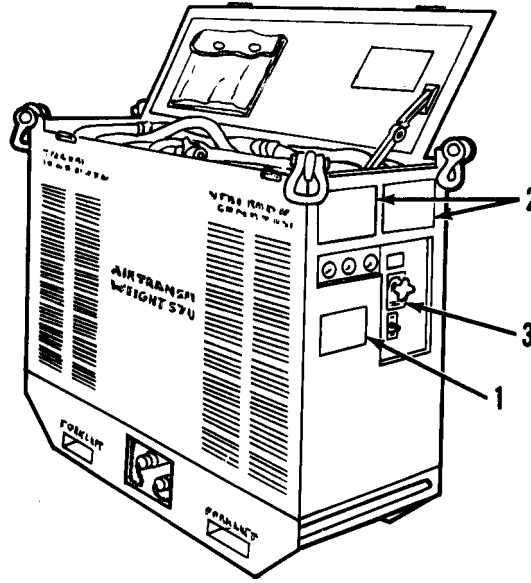

Water Heater

Key	Plate
1	<p data-bbox="407 1187 690 1223">Water Heater Nameplate</p> <div data-bbox="586 1285 1101 1644" style="border: 1px solid black; padding: 5px; margin: 10px 0;"> </div>

Key Plate

2 Operating Instruction Plates

HEATER OPERATING INSTRUCTIONS

TO ACTIVATE HEATER:

1. CONNECT WATER HEATER INLET AND OUTLET WATER HOSE.
2. MAKE CERTAIN HEATER IS FULL OF WATER BEFORE PROCEEDING.
3. REMOVE FUEL LINES FROM STORAGE COMPARTMENT AND CONNECT TO FUEL CONTAINER THEN TO WATER HEATER WITH BRASS CONNECTORS.
4. BE CERTAIN HEATER SWITCH IS IN "ON" PURGE POSITION.
5. CONNECT POWER CABLE TO 24 VOLT D.C. POWER SUPPLY.
6. ALLOW HEATER TO OPERATE IN PURGE POSITION FOR TWO MINUTES.
7. BE CERTAIN WATER IS FLOWING THROUGH THE HEATER.
8. TURN HEATER SWITCH TO "ON" POSITION AND ADJUST TEMPERATURE SELECTOR TO PRODUCE A FUEL PRESSURE READING OF 60 FOR 60°F FUEL OIL, 20 FOR FRESH OIL AND 75 FOR GASOLINE OR DIESEL FUEL. DO NOT EXCEED 150°F. SHOULD RETURN SWITCH TO PURGE POSITION AND DO NOT ATTEMPT TO RESTART UNTIL EXPERIENCED PERSONNEL SERVICED HEATER.

9. ALLOW HEATER TO OPERATE FOR 5 MINUTES - THEN READJUST TEMPERATURE SELECTOR GRADUALLY TO PRODUCE DESIRED WATER TEMPERATURE.

TO DEACTIVATE HEATER:

10. TURN SWITCH TO PURGE POSITION.
11. AFTER COMBUSTION CHASES ALLOW UNIT TO OPERATE FOR AT LEAST 2 MINUTES ON PURGE.
12. ALLOW WATER TO FLOW THROUGH HEATER FOR AT LEAST 3 MINUTES OR UNTIL DISCHARGE WATER IS APPROXIMATELY 100°F.
13. DISCONNECT UNIT FROM D.C. POWER SUPPLY AND COIL CABLE IN STORAGE COMPARTMENT.
14. DISCONNECT FUEL LINES AT HEATER - REMOVE FROM FUEL SUPPLY AND STORE IN STORAGE COMPARTMENT.
15. DISCONNECT OUTLET WATER HOSE AT TERMINATING END AND COIL NEATLY IN STORAGE COMPARTMENT. DISCONNECTING INLET HOSE AT BOTTOM OF HEATER WILL DRAIN UNIT.
16. CLOSE AND LATCH STORAGE COMPARTMENT COVER.

CS-59-226-2

3 Temperature Selector Plate

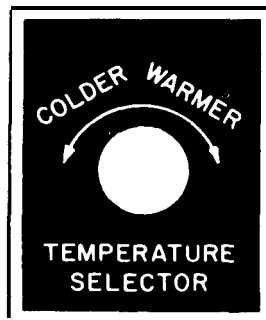
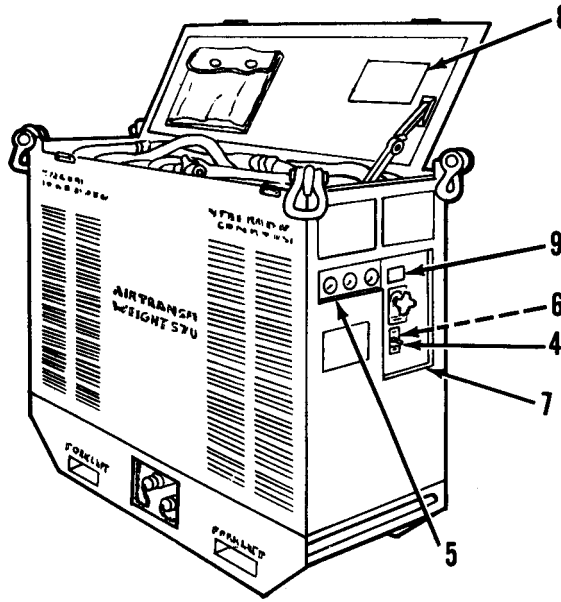
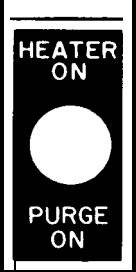

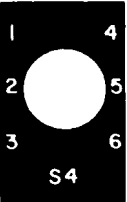

Table 2-5. OPERATING INSTRUCTIONS ON DECALS AND INSTRUCTION PLATES (CONT)



Water Heater

Key	Plate
4	Heater Control Switch Plate 
5	Gage Identification Plate 
6	S4 Terminal Plate 

Key | Plate

7 Relay and Timer Plates



8 Warning Plate



9 Warning Decal



Section IV. OPERATION UNDER UNUSUAL CONDITIONS

2-27. OPERATION IN UNUSUAL CONDITIONS.

CAUTION

Do not use an antifreeze mixture when mixing chemicals, A heat-releasing chemical reaction can occur when decontaminating agents are added,

Leave pump drain valve open at all times when equipment is not in use. This will prevent pump damage during freezing weather.

- a. *Cold Weather.* For operation in cold weather below 0°C(+32°F), winterize the decontaminating apparatus. Slurry becomes thicker as the temperature lowers and should not be used at fluid temperatures below 0°C (+ 32°F).

1

The diagram shows a control panel with the following components:

- VALVE NO 2 OVER RELIEF
- VALVE NO 3 UPPER RELIEF
- VALVE NO 4 LOWER RELIEF
- THROTTLE
- TACHOMETER
- PRESSURE GAUGE
- AMMETER BATTERY CHARGE
- GENERATOR
- OIL PRESSURE SWITCH STOP RUN START
- CHOKE
- FUEL CHOKE
- VALVE NO 2
- VALVE NO 3
- VALVE NO 4
- GENERATOR
- OIL PRESSURE SWITCH
- CHOKE
- FUEL CHOKE

Winterizing. During operation in extreme cold temperatures below - 17.8°C (0°F), use the manual CHOKe on the control panel to get the engine started. Allow the engine to warmup until it will maintain normal operation without aid of the manual choke before putting a load on it.

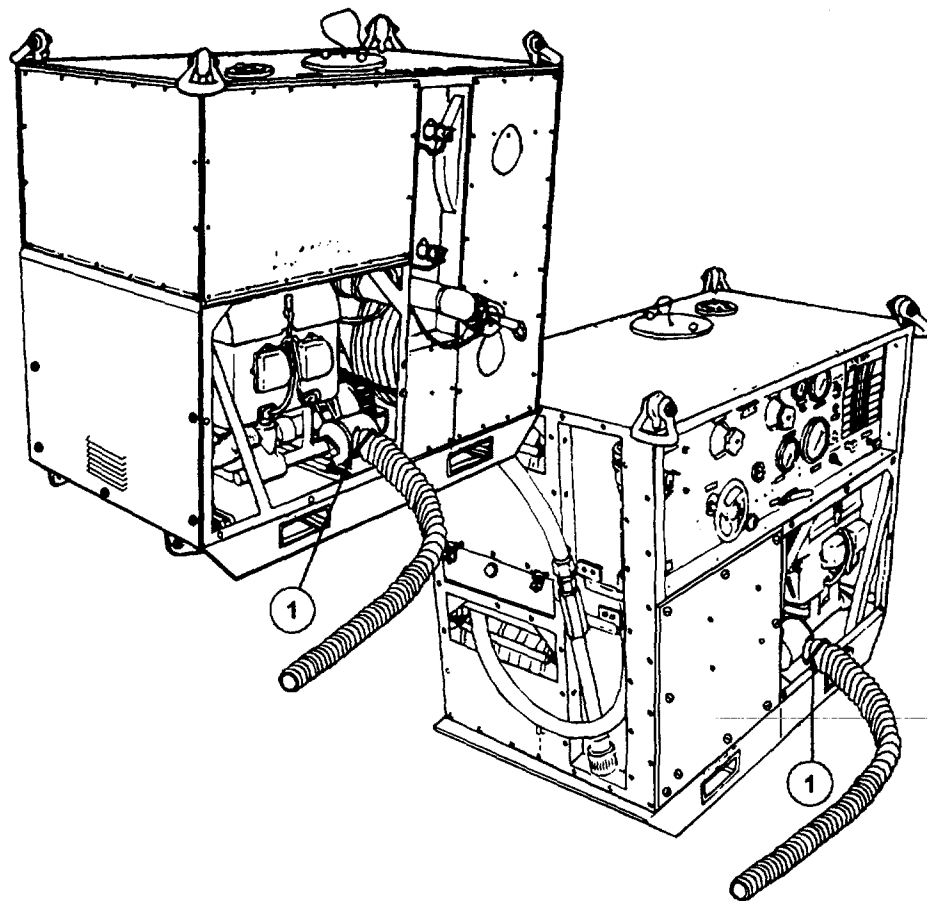
2**WARNING**

The gasoline engine and water heater exhausts can be lethal. Do not inhale these gases. A chemical-biological mask does not protect against carbon monoxide. When the decontaminating apparatus is to be operated, the exhaust gases must be vented away from the operator or outside of an enclosed area to prevent carbon monoxide poisoning.

- a. Remove only two of the four cover panels that are marked REMOVE BEFORE OPERATING. The two cover panels to be removed are next to the engine exhausts (1).
- b. Lubricate the engine with the grade of oil to be used in winter conditions (see LO 92805-259-12). Fill the fuel tank with automotive gasoline type A (item 14, app D) if temperatures are consistently below 32°F.

2-27. OPERATION IN UNUSUAL CONDITIONS (CONT).

a. *Cold Weather (Cont)*

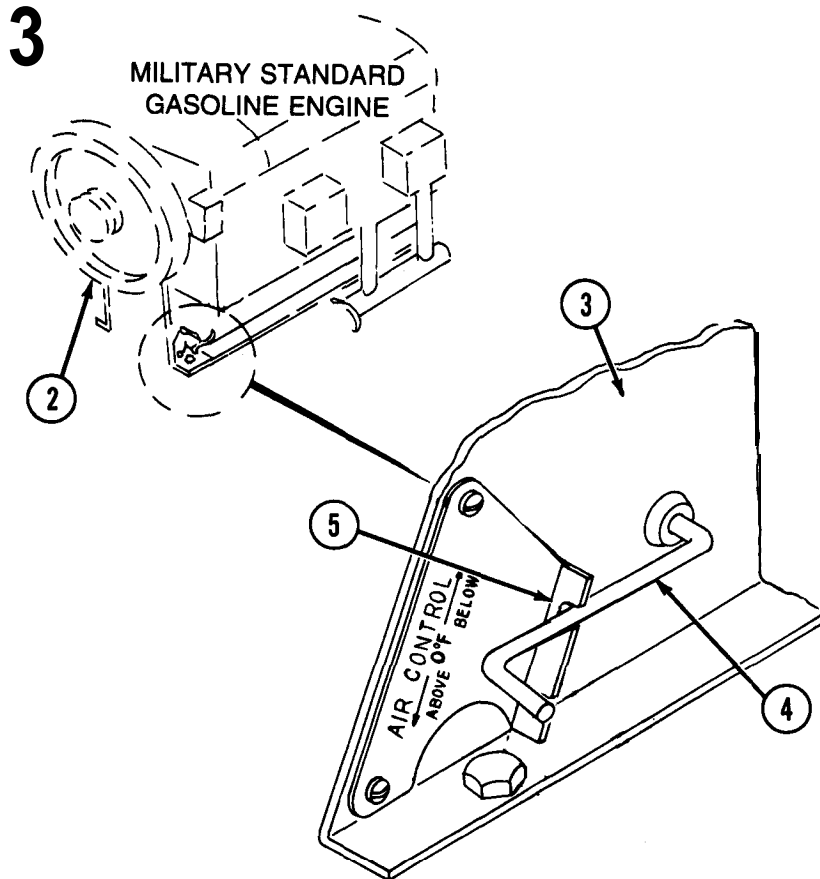

A fan (2) air-cools the engine. In extremely cold temperatures, close off the oil pan baffle to shutoff the cooling air. Use the air control handle on the rear engine mount (3) to open or close the oil pan baffle. Position the air control handle (4) to the 0° F below position in the retainer(5) for operation when temperatures are below 0°F.

4

CAUTION

Circulate only clear water through the water heater to avoid damage.

Preheat the water to prevent mixture from freezing before it can be used.

5

CAUTION

When using the decontaminating apparatus at temperature below 32° F, any liquid left in the piping, pump tank, or discharge may freeze and damage the equipment. If operations are interrupted, flush and drain the decontaminating apparatus.

Equipment failure. If the equipment fails (e.g., broken drive belts, engine trouble, etc) during cold weather while liquid is being sprayed, drain the apparatus.

- a. Open the gun assembly valves on the discharge hoses. Unreel the hoses from the hose reels to drain as much liquid as possible out of the discharge hoses and slurry nozzles.
- b. Open the pump DRAIN valve and open VALVE NO. 4 PRIME to drain as much liquid as possible out of the pump and prime-detergent tank.
- c. Disconnect the suction hose from the tank unit assembly and pump unit assembly. Open the tank drain valve and drain as much liquid as possible from the tank. Drain the suction hose, blender hose, and water heater.
- d. Notify organizational maintenance personnel to perform the necessary repairs.

6

CAUTION

Residual liquid in the piping, pump, and discharge hoses may freeze and damage the equipment if the water's circulation is interrupted.

Spraying water. At temperatures below 0°C (+ 32° F), spray water as follows:

- a. Winterize the decontaminating apparatus (para 2-27).
- b. Operate the engine and agitate the water that is in the tank unit through the pump unit until ready to spray. Heat water to a satisfactory temperature above freezing by using the water heater.
- c. Start spraying and continue spraying without interruption until the tank unit is empty. If water in the tank begins to freeze, use the water heater to heat the water, unless tank is loaded with chemicals.
- d. Drain the decontaminating apparatus.

2-27. OPERATION IN UNUSUAL CONDITIONS (CONT).

- a. *Cold Weather (Cont).*

7

Spraying slurry. At temperatures below 0°C (+32°F), spray slurry as follows:

- a. Winterize the decontaminating apparatus (para 2-27a).
- b. Fill the tank unit with water. Heat water to a satisfactory temperature above freezing using water heater. Disconnect water heater. Add the antiset compound (item 2, app D) (para 2-21b), STB DECON agent (item 7, app D) (para 2-21d), and silicone antifoam agent (item 1, app D) (para 2-21c). Agitate the mixture constantly until ready to spray.
- c. Start spraying. If spraying is stopped for five minutes or more, the slurry is likely to freeze.
- d. Procedure if spraying is stopped. If spraying of slurry is stopped for more than 5 minutes at temperatures below 0°C (+32°F), proceed as follows:
 1. If possible do not discontinue spraying operation until the tank unit assembly is empty or until the decontaminating mission is completed.
 2. Drain the slurry from the discharge hoses and piping (c above) and the tank unit assembly.
 3. Flush and drain the M12A1 decontaminating apparatus (table 2-4).
- e. Completion of spraying mission. After completing the spraying mission, flush the M12A1 decontaminating apparatus (table 2-4).
- f. Lubrication. Lubricate as required (LO 3-4230-209-10).

b. *Snow and Ice* Keep the decontaminating apparatus free of snow and ice as much as possible. The pump unit is completely enclosed with cover panels to protect the pump and engine. Use the canvas dust cover to protect the controls on the panel.

c. *Salt Water Areas and High Humidity* When operating in areas close to salt water or where the humidity is high, keep all exterior surfaces well painted. Watch for corrosion. Remove corrosion from electrical terminals by cleaning. Coat the battery terminals with GAA (item 16, app D) (see LO 3-4230-209-10). Refer to

- TM 9-2805-259-14 for engine protection and precautions to be observed. Refer to
- TM 9-6140-200-14 for battery protection and precautions to be observed.

d. Extreme Heat. Inspect the rubber hoses once a week for signs of wear and damage. Rubber deteriorates rapidly in extreme heat.

e. Sand or Dust. Keep the cover panels and dust cover in place as much as possible. Position the pump unit in a direction that will afford the greatest protection to the engine compartment. Keep lubricants free from dust and grit. Do not overlubricate as dust and grit adhere to the lubricant and will work into lubricated areas. Position the pump unit assembly in a direction that will afford the greatest protection to the engine compartment. Refer to TM 9-2805-259-14 for engine protection. ■

CHAPTER 3
MAINTENANCE INSTRUCTIONS

Section I. LUBRICATION INSTRUCTIONS

3-1. GENERAL The lubrication order, LO 3-4230-209-10, is for the M12A1 decontaminating apparatus. It is stored in the canvas pouch on the pump unit cover panel. The lubrication order, LO 9-2805259-12, is for the 20 HP military standard engine. It is stored in the tool carrier of the pump unit. Both lubrication orders must be with the M12A1 decontaminating apparatus at all times. If not, request copies immediately. If any discrepancies arise, only the LOs are authorized.

3-2. LUBRICATION INSTRUCTIONS Lubricate according to LO 3-4230-209-10 and LO 9-2805-259-12.

3-3. GENERAL CLEANING INSTRUCTIONS The pump unit, tank unit, and water heater should be cleaned once a week to maintain their appearance and to enable each item to function properly. Use hot, soapy water and a brush to remove hardened slurry or dirt from the exterior surfaces, gun and nozzle assemblies, hoses, the personnel shower assembly, and the tank unit.

WARNING

Fire and explosion danger exist when dry cleaning solvent (SD) is used. Make sure that equipment is dry before operations begin.

CAUTION

Do not wash the interior of the pump unit or the water heater with dry cleaning solvent. Do not wash the control panels with water. Rinse all parts washed with soap and water with clean water. Dry all parts thoroughly.

1

- a. *Control Panels* Wipe all switches and gages with a wiping rag (item 22, app D). Stubborn stains, oil, or grease may be removed with a cloth dampened with dry cleaning solvent (item 10, app D).
- b. *Unpainted Metal Parts and Interior of Pump Unit and Water Heater* Clean with a wiping rag (item 22, app D) dampened with dry cleaning solvent (item 10, app D) and dry thoroughly.

3-3. GENERAL CLEANING INSTRUCTIONS (CONT).

2

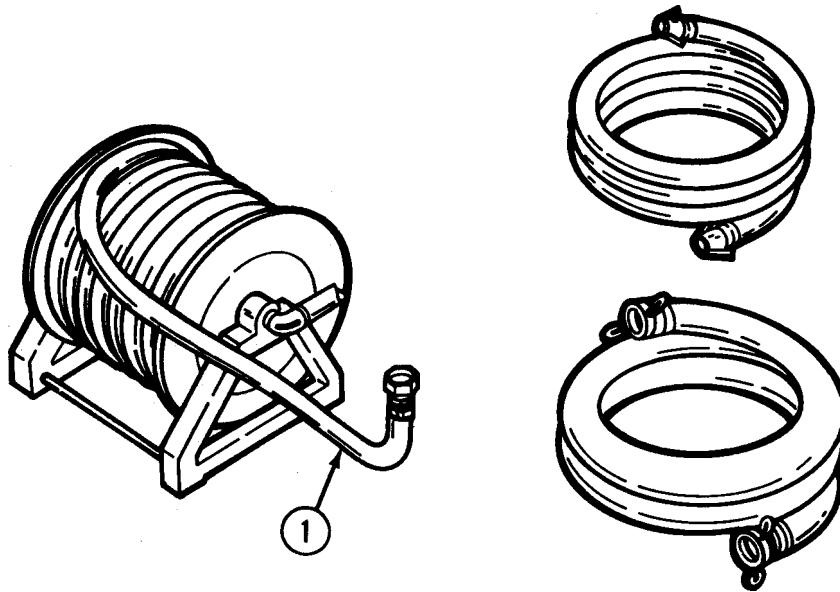

Hoses. Flush the hoses with hot water. Wash the exterior of the discharge hose (1) with hot, soapy water. Dry all parts thoroughly. Clean metal parts with a cloth dampened with dry cleaning solvent (item 10, app D), if required.

3

WARNING

When working around or on the storage battery, always disconnect the ground cable first. Wear eye protection when working with storage battery. The storage battery contains acid which can blind or burn you. Do not allow battery acid to get on clothing.

Battery. Clean the battery with a dry cloth (item 22, app D). If the battery is corroded, clean with a scrub brush (item 3, app D) (any brush without wire bristles) dipped in a solution of bicarbonate of soda (baking soda) (item 23, app D) and water. After the foaming action stops, flush the exterior surfaces of the battery with clean water and wipe dry with a clean cloth (item 22, app D). To prevent corrosion, coat the terminals (2) and cable connections (3) with GAA lubricant (item 16, app D) after connecting the battery cables, positive first, then negative.

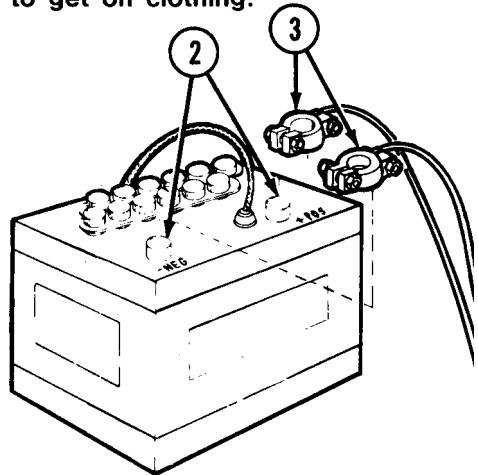

3-2 Change 1

PIN: 060191-001

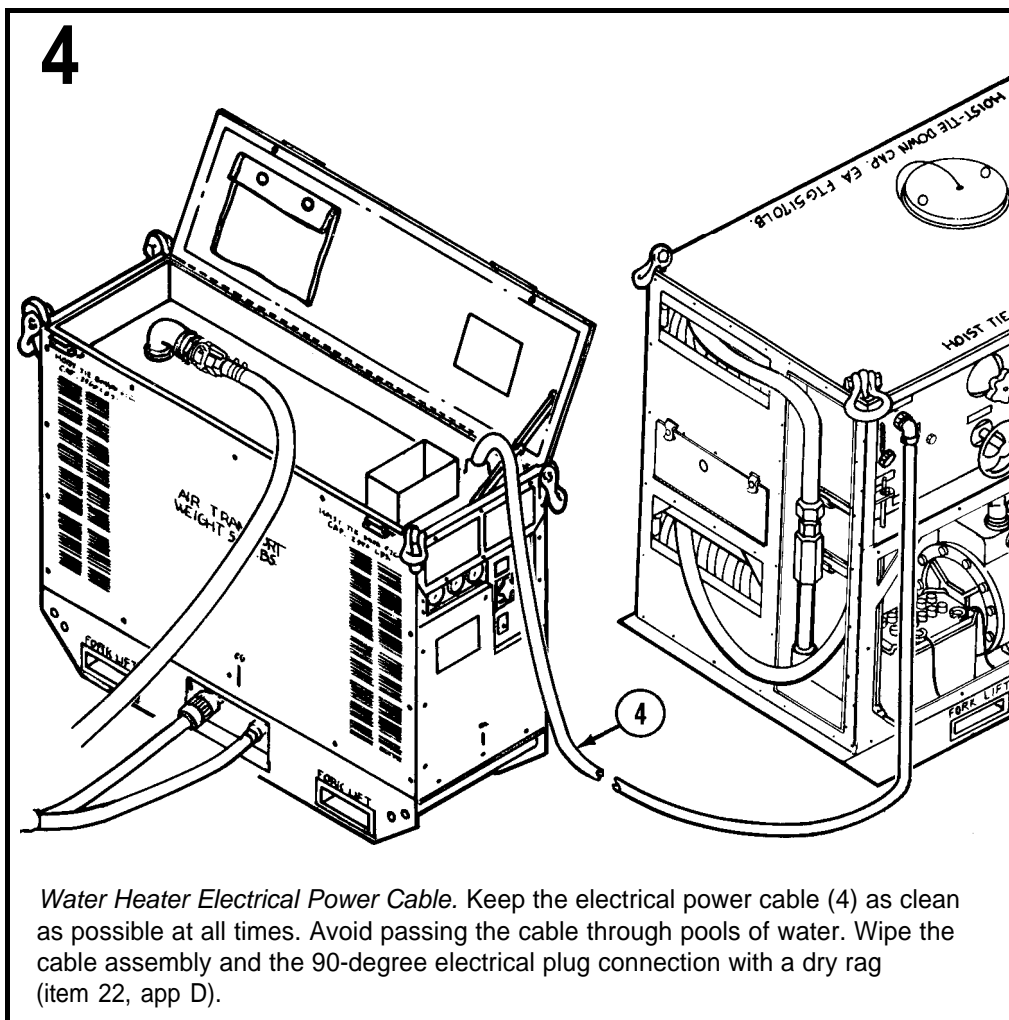

Section II. TROUBLESHOOTING PROCEDURES

3-4. INTRODUCTORY INFORMATION.

a. Table 3-1 lists the common malfunctions which you may find during the operation or maintenance of the decontaminating apparatus or its components. You should perform the tests/inspections and corrective actions in the order listed.

b. This manual cannot list all malfunctions that may occur, nor all tests or inspections and corrective actions. If a malfunction is not listed or is not corrected by listed corrective actions, notify unit maintenance personnel.

Table 3-1. TROUBLESHOOTING

MALFUNCTION	TEST OR INSPECTION	CORRECTIVE ACTION
-------------	--------------------	-------------------

PUMP UNIT

1. ENGINE FAILS TO START.

WARNING

Inspect the fuel tank in daylight. If a light is required, use a vapor resistant light.

Step 1. Inspect to see if FUEL SHUT OFF valve (as illustrated) is closed or if finger nut on sediment bowl is off.

- a. Open FUEL SHUT OFF valve and sediment bowl valve.
- b. Press FUEL INDICATOR switch (as illustrated) and hold it into check the amount of fuel in the tank as indicated by the fuel quantity gage.
- c. Remove the fuel tank cap and inspect to see if fuel is in the tank. Add fuel to tank as required.

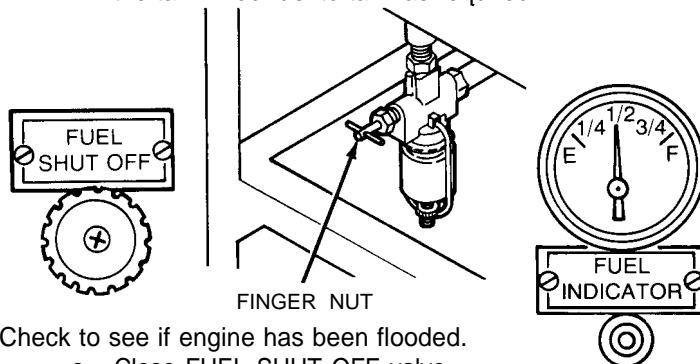

Step 2. Check to see if engine has been flooded.

- a. Close FUEL SHUT OFF valve.
- b. Pull manual choke. (The manual choke control is on the control panel.)
- c. Crank engine for one-half minute.
- d. Push in manual choke.
- e. Reopen FUEL SHUT OFF valve.

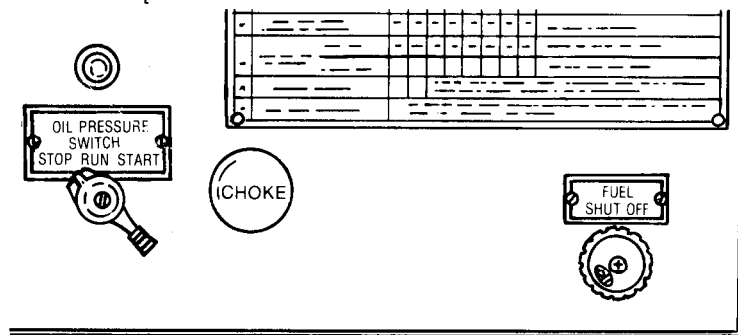

MALFUNCTION

TEST OR INSPECTION

CORRECTIVE ACTION

Step 3. Inspect CIRCUIT BREAKER mounted on the control panel to determine if it has been tripped.
 Reset CIRCUIT BREAKER by turning switch to OFF and then back to ON.

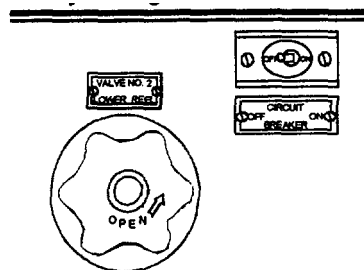

Step 4. Inspect engine fuse mounted on the engine regulator-rectifier (as illustrated). Make sure it is not burned out.
 Replace fuse (TM 92805-25914) with the spare fuse and then replace the spare fuse with a new fuse.

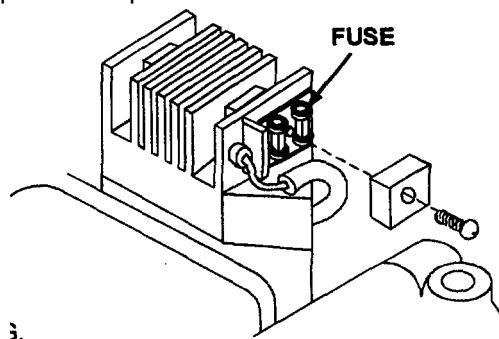

2. PUMP PRESSURE LOW OR FALLING.

Step 1. Check engine speed indicated by RPMs on TACHOMETER.
 Increase the engine speed by rotating the throttle clockwise until TACHOMETER indicates about 3,850 RPM. If RPMs are not satisfactory, notify unit maintenance.

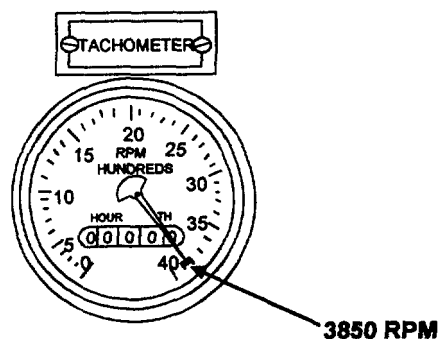

Table 3-1. TROUBLESHOOTING (CONT)

MALFUNCTION	TEST OR INSPECTION	CORRECTIVE ACTION
-------------	--------------------	-------------------

2. PUMP PRESSURE LOW OR FALLING (CONT).

Step 2. Check drive belts for proper tension with tensiometer. Adjust drive belt tension (para 3-7).

Step 3. Check to see that VALVE NO. 4 PRIME (as illustrated) is closed after priming pump and before prime-detergent tank is empty.

- a. Close VALVE NO. 4 PRIME.
- b. Refill prime-detergent tank.
- c. Open VALVE NO. 4 PRIME and prime pump.
- d. Close VALVE NO. 4 PRIME before tank is empty.

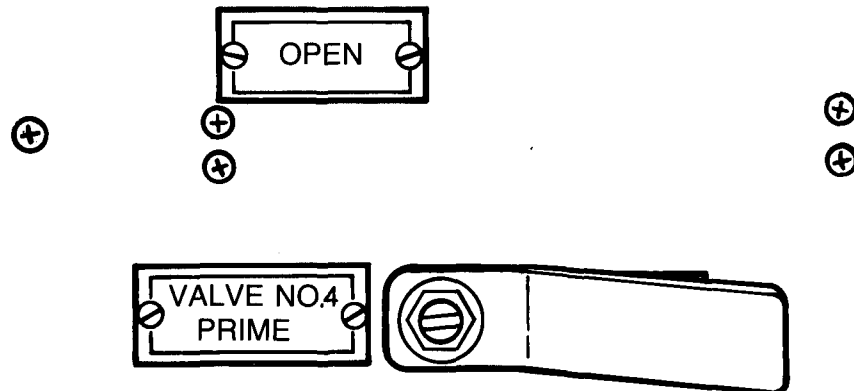

3. PUMP INOPERATIVE (FAILS TO OPERATE).

Step 1. Check to see that VALVE NO. 4 PRIME is closed after priming pump and before prime-detergent tank is empty.

- a. Close VALVE NO. 4 PRIME.
- b. Refill prime-detergent tank.
- c. Open VALVE NO. 4 PRIME and prime pump.
- d. Close VALVE NO. 4 PRIME before tank is empty.

Step 2. To check to see if VALVE NOS. 1,2, or 3 are closed, open one or more of these valves. See instruction on starting procedure plate.

MALFUNCTION

TEST OR INSPECTION

CORRECTIVE ACTION

- Step 3. Check for loose or broken belts.
Adjust drive belts (para 3-7) if required.
- Step 4. Check to see if the connection is loose on the suction line.
Tighten connection.
- Step 5. Check to see if suction hose is plugged with dirt.
Clean suction hose.
- Step 6. If foot valve is used, check to see if it is clogged.
Clean foot valve.

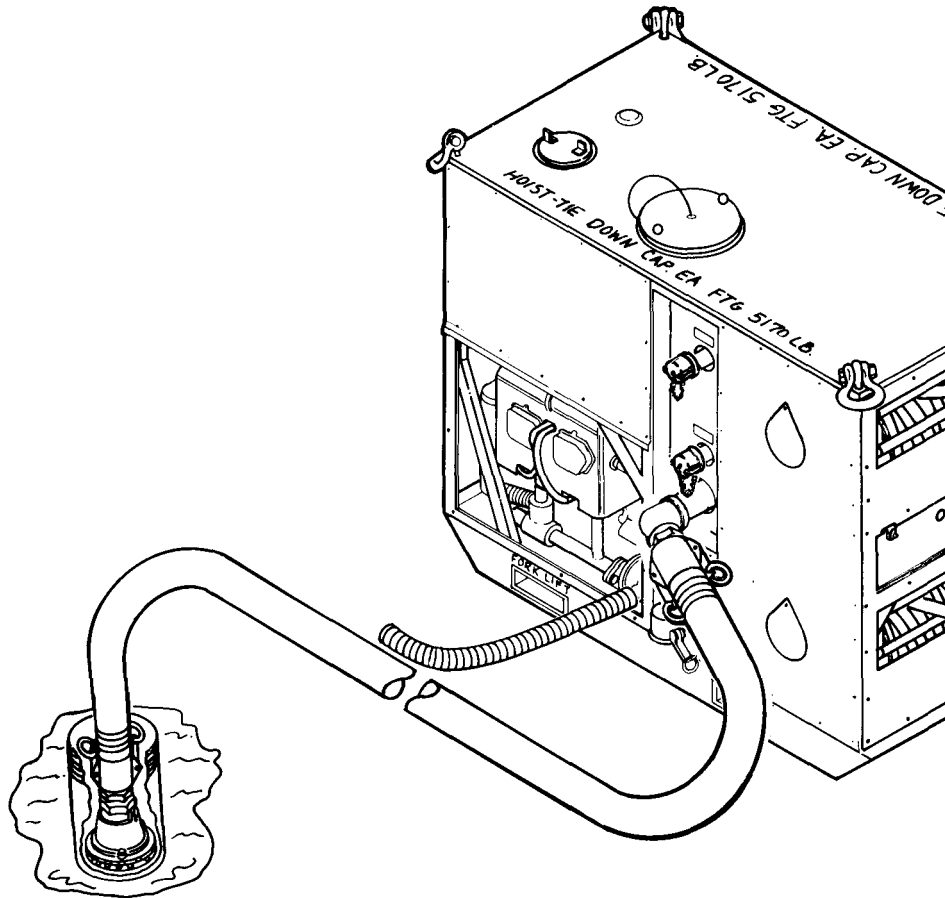

- Step 7. Check pump suction. Open VALVE NO. 4 PRIME and remove suction hose from inlet piping. Operate pump and hold the palm of your hand against the suction inlet. If there is no pull against the palm of your hand, the pump is bad.

Table 3-1. TROUBLESHOOTING (CONT)

MALFUNCTION	TEST OR INSPECTION	CORRECTIVE ACTION
-------------	--------------------	-------------------

4. PUMP VIBRATES EXCESSIVELY.

Step 1. Visually inspect to determine if pump mounting is loose.
Tighten mounting nuts and adjust belts (para 3-7).

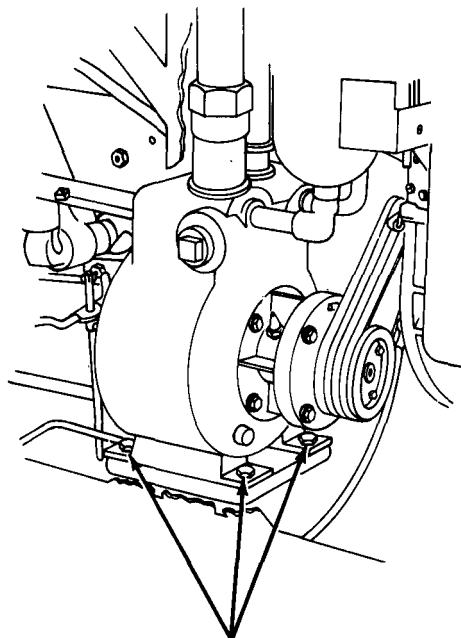

PUMP MOUNTING

Step 2. Check to see if pump drive pulley on pump shaft is loose, broken, or bent.
Tighten pulley on pump shaft.

5. PUMP OVERHEATS OR IS NOISY.

Check logbook to see if lubrication fitting on pump was lubricated.
Lubricate pump with correct lubricant (LO 3-4230-209-10).

MALFUNCTION

TEST OR INSPECTION

CORRECTIVE ACTION

WATER HEATER

1. BURNER SPUTTERS OUT.

Step 1. See if there is fuel in the gasoline can.
Refill gasoline can.

Step 2. Check FUEL PRESSURE setting gage reading (as illustrated) to assure that the fuel pressure is correct for the type of fuel being burned. Pressure gage reading should be at least 60 psi for No. 2 fuel oil, 70 psi for kerosene and 75 psi for gasoline or JP-5.
Restart burner and reset fuel pressure.

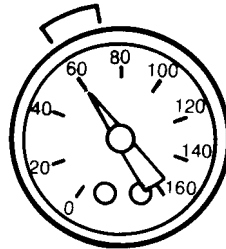

FUEL PRESSURE

Step 3. Remove cap and inspect to see that air is not in the fuel returning to the fuel supply container. Operate in PURGE ON for 2-minute minimum until fuel is clear. Check to see if air is leaking into the hose where the guide disconnect joins to the heater. Apply GAA lubricant (item 16, app D) to quick disconnect for test.

If burner stops sputtering, air leak is present. Notify unit maintenance.

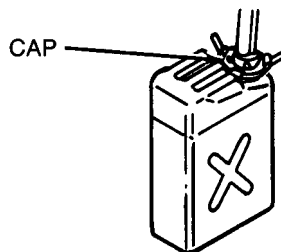

Step 4. Check main power cable for loose or broken connections.
If cable is hot, notify unit maintenance.

Table 3-1. TROUBLESHOOTING (CONT)

MALFUNCTION	TEST OR INSPECTION	CORRECTIVE ACTION
-------------	--------------------	-------------------

1. BURNER SPUTTERS OUT (CONT)

Step 5. Check HEATER RECEPTACLE AND SWITCH on pump unit for loose power cable connection to be sure there is power.
Tighten power cable connection.

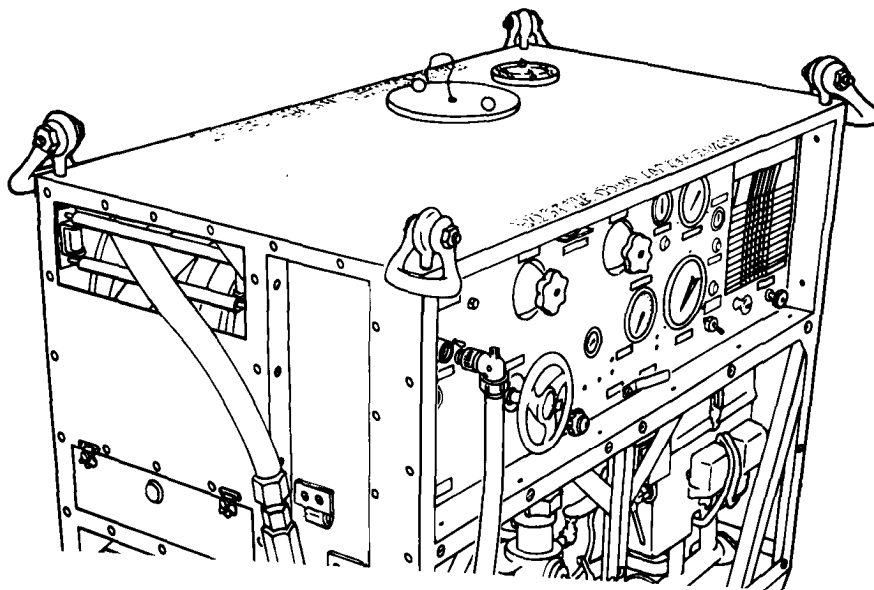

Step 6. Check for loose plug or receptacle on the combustion air blower motor.

Tighten loose connections.

Step 7. Check for broken drive arms on fuel pump, combustion magneto, and fuel pump and ignition drive motor.

Step 8. Check for steam or water escaping from the gasket on the refractory-box end of the low pressure heating boiler,

Step 9. Check for a defective or worn fuel pump. With water heater operating in PURGE ON, visually inspect that fuel pump and ignition drive motor is turning.

MALFUNCTION	TEST OR INSPECTION	CORRECTIVE ACTION
-------------	--------------------	-------------------

Step 10. Check for frozen fuel pump. Stop operation. Remove electrical power. Use screwdriver to free shaft of the fuel pump so it will turn. If gasoline is used, add one pint of grade 30 motor oil (item 18, app D) to each 5 gallons of gasoline. If gasoline is used without adding grade 30 motor oil, the fuel pump will freeze. Check to see if fuel is leaking in the fuel pump area.

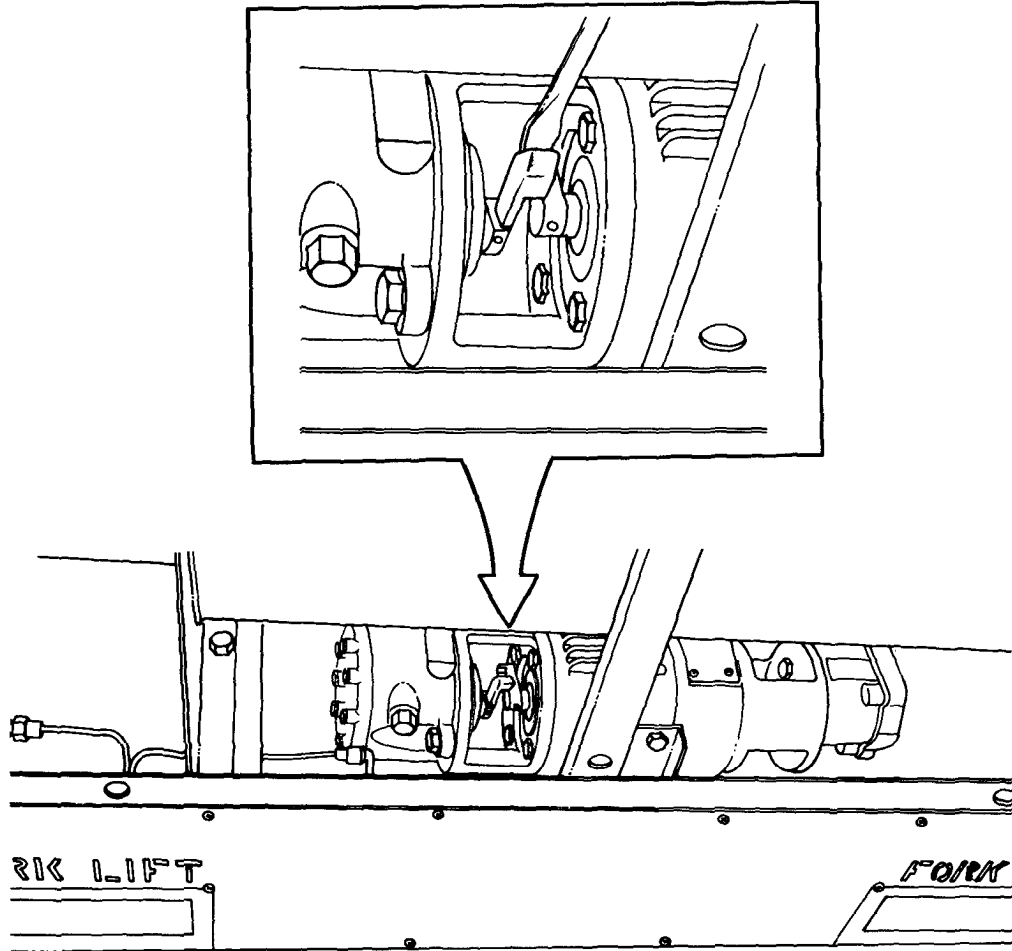

Step 11. Visually check for leaking fuel lines.

2. WATER TOO HOT.

Step 1. Check WATER TEMPERATURE gage on front of heater. If gage indicates temperatures of 200° F or higher, the automatic control and safety devices of the water heater are defective. Shut off heater and notify unit maintenance.

Table 3-1. TROUBLESHOOTING (CONT)

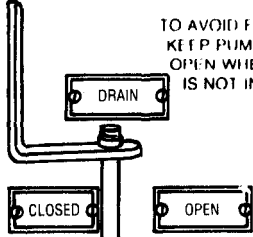
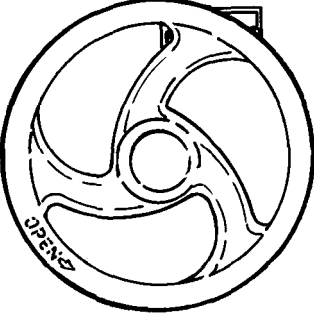
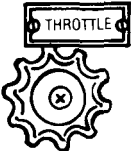
MALFUNCTION	TEST OR INSPECTION	CORRECTIVE ACTION
	Step 2. Check to determine if water flow is too slow.	Increase water flow by opening valve No. 1 completely.
<div style="display: flex; align-items: center; justify-content: space-around;"> <div style="text-align: center;">  </div> <div style="text-align: center;"> <p>CAUTION</p> <p>TO AVOID FREEZE DAMAGE KEEP PUMP DRAIN VALVE OPEN WHEN EQUIPMENT IS NOT IN OPERATION</p> </div> <div style="text-align: center;">  </div> <div style="text-align: center;">  </div> </div>		

Step 3. If shower assembly is used, check for clogged strainer in shower assembly.

Stop equipment and clean screen in strainer (item 3, table 2-2).

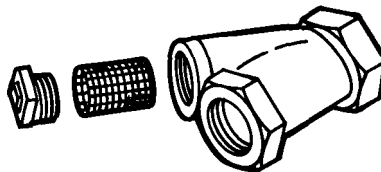

Step 4. If discharge hoses are used, check for clogged discharge hoses.
Flush discharge hoses.

3. WATER NOT HOT ENOUGH.

Step 1. Check for rapid flow rate of water.

Adjust valve No. 1 to slow proper flow rate and correct temperature. If correct temperature cannot be reached, notify unit maintenance.

Step 2. Check for leaking fuel lines and defective or worn fuel pump. See Burner Sputters Out, steps 9,10, and 11.

Step 3. Check for improperly connected hoses.
Connect hoses properly.

MALFUNCTION	TEST OR INSPECTION	CORRECTIVE ACTION
-------------	--------------------	-------------------

4. ADDITIVES FAIL TO MIX IN SOLUTION.

Step 1. Check to see that decontaminating agent and water are blended properly.

Blend decontaminating agent and water in accordance with instructions on STARTING PROCEDURE plate (para 2-21).

Step 2. Check for improper connections.

Connect hoses properly in accordance with instructions on STARTING PROCEDURE plate (para 2-21).

Step 3. Check for settled solution and plugged agitator or blender pipe.

Clean obstructions and remove settled slurry from equipment (items 31 or 41, table 2-2).

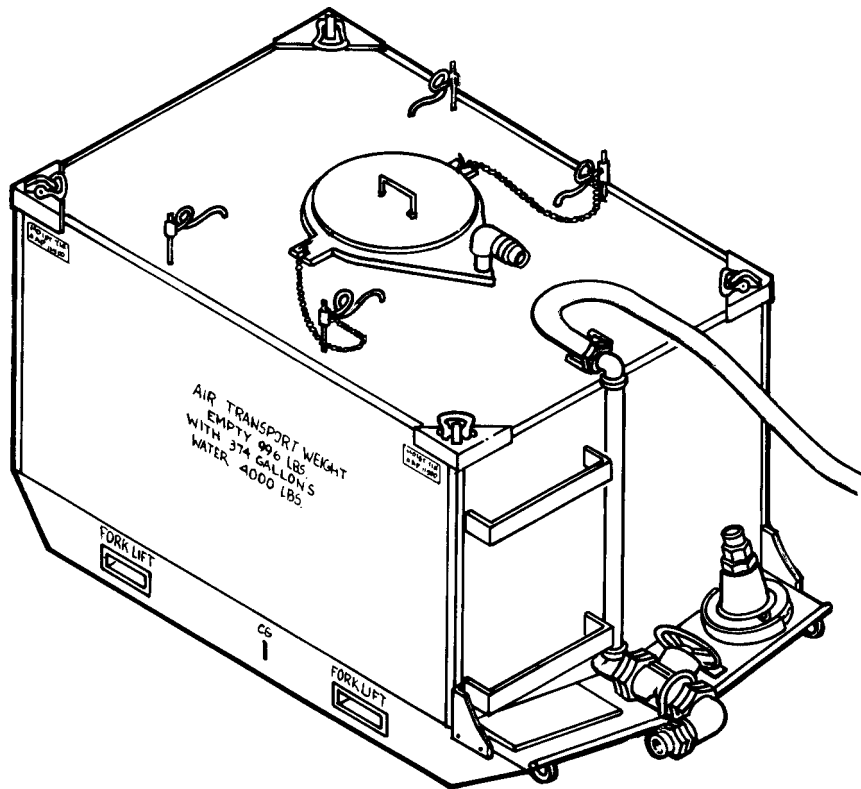

Section III. MAINTENANCE PROCEDURES

3-5. PERSONNEL SECTIONAL SHOWER ASSEMBLY.

Check and replace gaskets in the couplings, as required. Gaskets are 1 1/2 inch diameter.

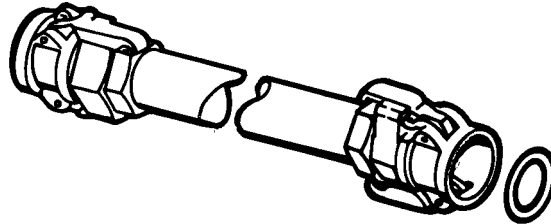

3-6. GUN ASSEMBLY.

1

ALL-BANN
SLURRY
NOZZLE

ROCKWOOD
SLURRY
NOZZLE

WATER
NOZZLE

FOAM NOZZLE

Replace Nozzle.

NOTE

Use the following instructions to replace slurry nozzle, fire nozzle or foam nozzle and unserviceable gasket.

- 1 Remove nozzle (1) and 1 inch diameter gasket (2) from extension pipe (3).
- 2 Place 1 inch DIA gasket (2) into seat in threaded end of nozzle (1).
- 3 Install nozzle (1) on extension pipe (3). Do not overtighten.

2 Install Gun Assembly on the Discharge Hose.

Connect hose coupling (1) to adapter (2). Using two adjustable wrenches, tighten hose coupling (1) on adapter (2). Do not over-tighten.

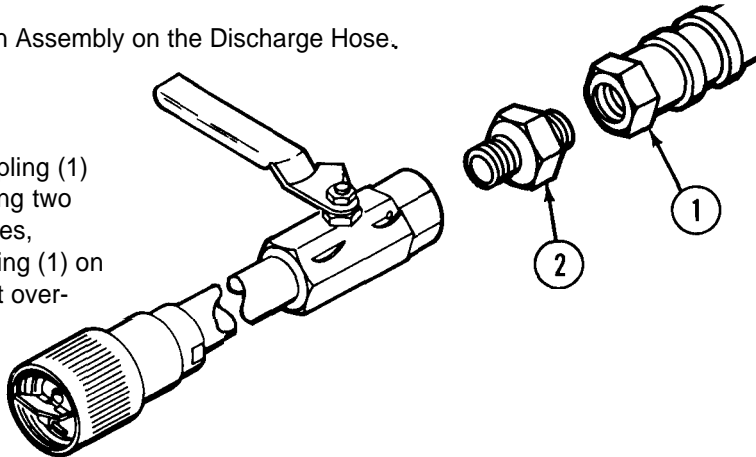

3-7. PUMP UNIT SUBASSEMBLY.

1

WARNING

Avoid contact with the battery's positive connection at the starter solenoid when adjusting the belt tension. Electrical shock, fire, or damage to the equipment may result.

NOTE

New drive belts should be adjusted after 50 hours of use (as indicated on the TACHOMETER-hourmeter) since they may stretch slightly.

Adjust pump drive belts, first. Then adjust alternator drive belt.

3-7. PUMP UNIT SUBASSEMBLY (CONT).

2

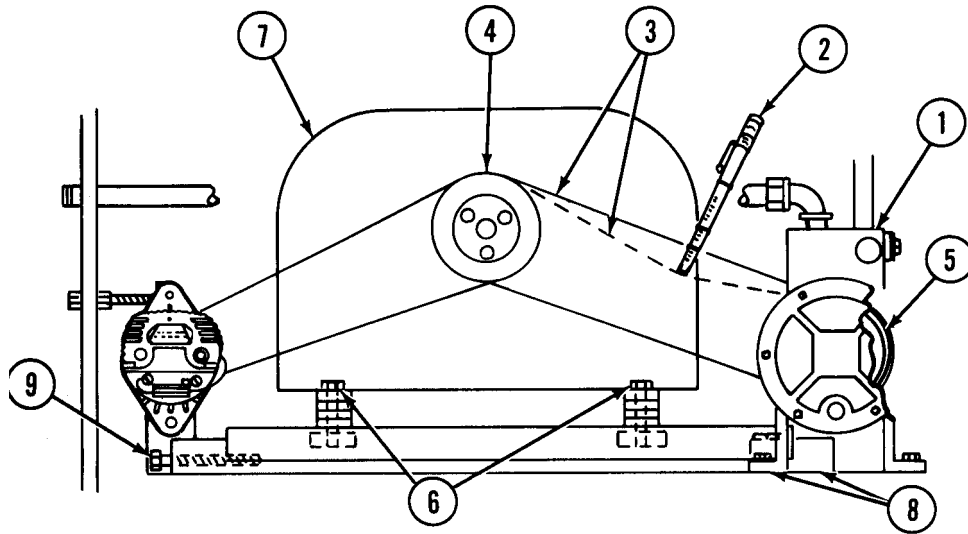

Pump Drive Belt Adjustment.

- 1 Adjust pump (1) belt tension using tensiometer (2), which can be found in the tool box.
- 2 Set the O-ring on the small end of tensiometer (2) at the 3/8-inch mark and set the other O-ring against the outer movable surface of the tensiometer.
- 3 Place the small end of tensiometer (2) against one of the four drive belts (3) at a point halfway between drive pulley (4) and driven pulley (5).
- 4 Press down on the drive belt (3) until the O-ring at the 3/8-inch mark touches against an adjacent drive belt (3).
- 5 Withdraw tensiometer (2) and read the indication of the second O-ring, which was moved along the scale by the amount of pressure applied. The indication should be between 5 and 7 pounds.
- 6 If the tension is unsatisfactory, use a wrench to loosen two lock screws (6) that fasten engine (7) to mounting (8).
- 7 Turn in or back out the adjusting bolt (9) on the engine mounting (8) to apply or remove tension as required.
- 8 Test the tension on all four drive belts (3). Tighten the engine mounting lock screws (6) when the belt tension is satisfactory. If the four drive belts (3) must be replaced, notify unit maintenance.

3

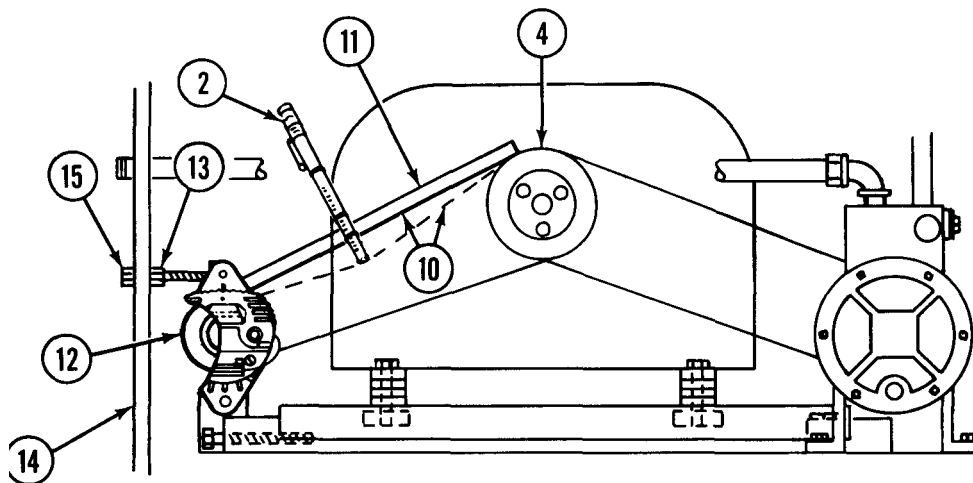

Alternator Drive Belt Adjustment.

- 1 Adjust the alternator belt (10) tension by using the tensiometer (2).
- 2 Set the O-ring on the small end of tensiometer (2) at the 3/8-inch mark and set the other O-ring against the outer movable surface of the tensiometer.
- 3 Lay a straightedge (11) between the two pulleys (4 and 12) along the top edge of alternator belt (10).
- 4 Press down on alternator belt (10) with tensiometer (2) until the O-ring at the 3/8-inch mark touches straightedge (11).
- 5 Withdraw tensiometer (2) and read the indication on the second O-ring which was moved along the scale by the amount of pressure applied. The indication should be between 5 to 7 pounds.
- 6 If the tension is unsatisfactory, use a wrench to loosen lock-nut (13) in frame assembly (14) that fastens adjusting bolt (15) against frame assembly (14).
- 7 Turn in or back out adjusting bolt (15) to increase or release the tension.
- 8 Test the tension several times using tensiometer (2).
- 9 When alternator belt (10) tension is satisfactory, fasten the locknut (13) against frame assembly (14) to prevent any movement of the adjusting bolt (15).
- 10 Put the tools in the tool box of the pump unit.
- 11 If alternator belt (10) must be replaced, notify unit maintenance personnel.

3-8. 20 HP GAS ENGINE ASSEMBLY.

Replace fuse (1)
(TM 9-2805-259-14)
when required.

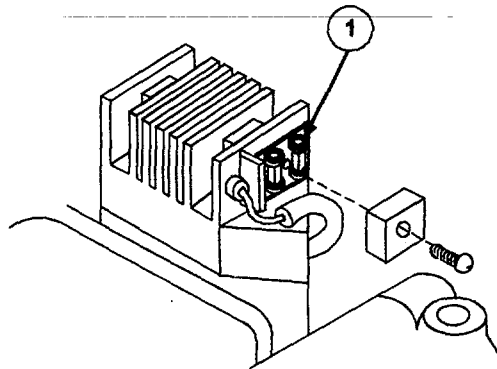

**APPENDIX A
REFERENCES**

A-1. SCOPE This appendix lists all forms, field manuals, technical manuals and miscellaneous publications referenced in this manual.

A-2. FIELD MANUALS

- FM 3-5..... NBC Decontamination
- FM 21-11 First Aid for Soldiers

A-3. TECHNICAL MANUALS

- TM 3-4240-279-10 Operator's Manual: Mask, Chemical-Biological: Field M17/M17A1 and Accessories
- TM 9-2805-259-14 Operator, Unit, Direct Support, and General Support Maintenance Manual: Engine, Gasoline, 20 HP; Military Standard Models (Model 4A084-2) (NSN 2805-00-925-3926), (Model 4A084-3) (NSN 2805-00-872-5972) and (Model 4A084-4) (NSN 2805-01-276-5947)
- TM 9-6140-200-14 Operator's, Organizational, Direct Support, and General Support Maintenance Manual for Lead-Acid Storage Batteries: 4HN, 24 Volt (6140-00-059-3528) MS75047-1 2HN, 12 Volt (6140-00-057-2553) MS35000-1 6TN, 12 Volt (6140-00-057-2554) MS35000-3
- TM 10-277 Chemical, Toxicological and Missile Fuel Handlers Protective Clothing

TM 3-4230-209-10

A-4. LUBRICATION ORDERS.

- LO 3-4230-209-10..... Decontaminating Apparatus, Power Driven, Skid-Mounted, Multipurpose, Nonintegral, 500 Gallon, M12A1
- LO 9-2805-259-12..... Engine, Gasoline, 20 HP, Military Standard Models (Model 4A084-2, 4A084-3 and 4A084-4)

A-5. MISCELLANEOUS PUBLICATIONS.

- DA PAM 738-750..... The Army Maintenance Management System (TAMMS)

A-6. FORMS.

- CTA 8-100 Army Medical Department Expendable/Durable Items
- CTA 50-970 Expendable/Durable Items (except Medical, Class V, Repair Parts, and Heraldic Items)
- DA Form 2028 Recommended Changes to Publications and Blank Forms
- DA Form 2028-2 Recommended Changes to Equipment Technical Publications
- DA Form 2404. Equipment Inspection and Maintenance Worksheet
- SF 368..... Quality Deficiency Report

APPENDIX B

COMPONENTS OF END ITEM AND BASIC ISSUE ITEMS LIST

Section 1. INTRODUCTION

B-1. SCOPE. This appendix lists components of end item and basic issue items for the decontaminating apparatus to help you inventory items required for safe and efficient operation.

B-2. GENERAL. The Components of End Item (including on-board spares) and Basic Issue Items Lists are divided into the following sections:

a. *Section II. Components of End Item.*

(1) Components of end item. This listing is for informational purposes only and is not authority to requisition replacements. These items are part of the end item but are removed and separately packaged for transportation or shipment. As part of the end item, these items must be with the end item whenever it is issued or transferred between property accounts. Illustrations are furnished to assist in identifying the items.

(2) On-board spares. On-board spares are extra items identified as essential to be available at all times for operator/crew support of the end item. This list is for authorization of these items. Illustrations are furnished to assist you in identifying the items.

b. *Section III. Basic Issue Items.* These are the minimum essential items required to place the decontaminating apparatus in operation, to operate it, and to perform emergency repairs. Although shipped separately packaged, BII must be with the decontaminating apparatus during operation and whenever it is transferred between property accounts. The illustrations will assist with hard-to-identify items. This manual provides authority to request/requisition replacement BII, based on TOE/MTOE authorization of the end item.

B-3. EXPLANATION OF COLUMNS. The following provides an explanation of columns found in the tabular listings:

a. *Column (1) - Illustration Number (Illus Number).* This column indicates the number of the illustration in which the item is shown.

b. *Column (2) - National Stock Number.* Indicates the National stock number assigned to the item and will be used for requisitioning purposes.

c. *Column (3) - Description.* Indicates the Federal item name and, if required, a minimum description to identify and locate the item. The last line for each item indicates the FSMC (in parentheses) followed by the part number.

d. *Column (4) - Unit of Measure (U/M).* Indicates the measure used in performing the actual operational/maintenance function. This measure is expressed by a two-character alphabetical abbreviation (e.g., ea, in., pr).

e. *Column (5) - Quantity Required (Qty Rqr).* Indicates the quantity of the item authorized to be used with/on the equipment.

Section II. COMPONENTS OF END ITEM

(1) Illus Number	(2) National Stock Number	(3) Description FSCM and Part Number	Usable On Code	(4) U/M	(5) Qty Rqr
1	5340-00-944-6089	COMPONENTS OF THE END ITEM CRANK, HAND (81361) 5-45-3342		EA	1

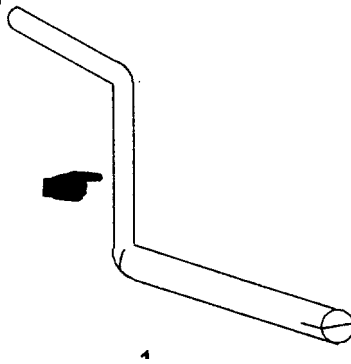

(1) Illus Number	(2) National Stock Number	(3) Description FSCM and Part Number	Usable On Code	(4) U/M	(5) Qty Rqr
		<i>ON-BOARD SPARES</i>			
1	5330-00-811-9472	GASKET, 1 inch dia. (81361) B5-45-2934		EA	3
2	5330-00-787-7417	GASKET, 1 1/2 inch dia. (81361) B5-45-3130-1		EA	5

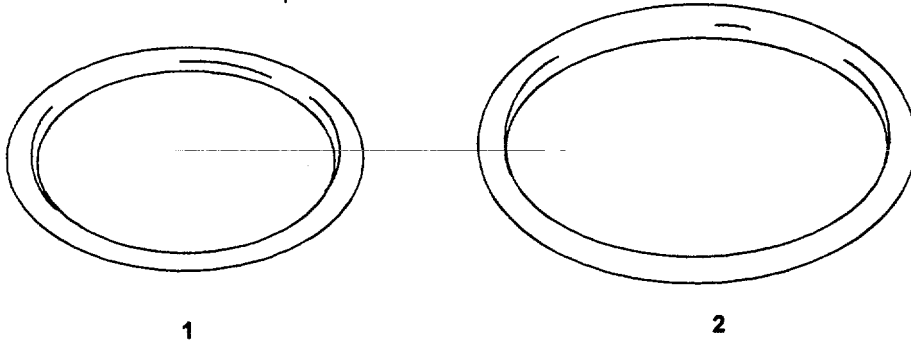

Section III. BASIC ISSUE ITEMS

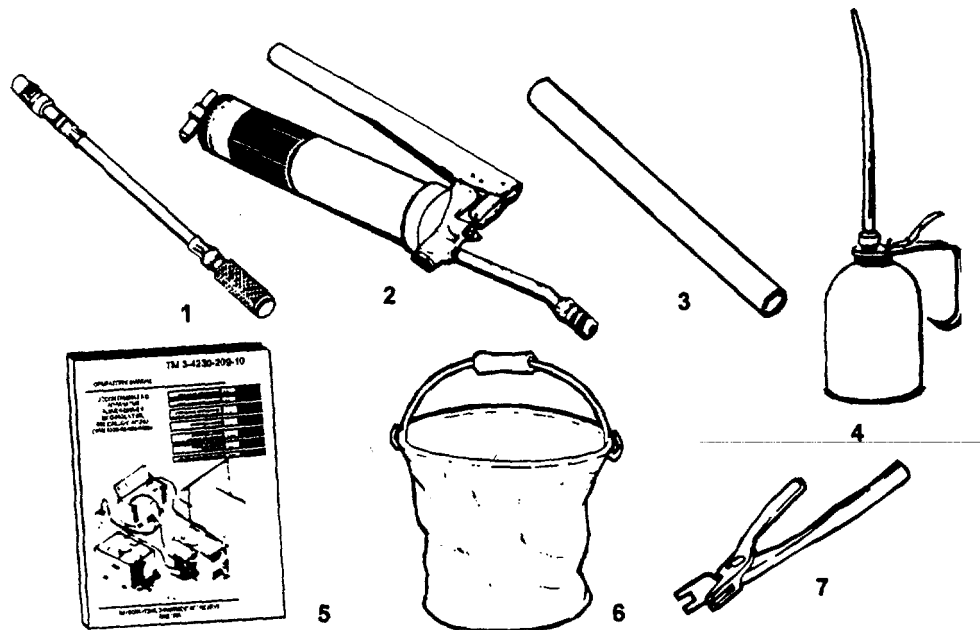

(1) Illus Number	(2) National Stock Number	(3) Description FSCM and Part Number	Usable On Code	(4) U/M	(5) Qty Rqr
1	4930-00-288-1511	ADAPTER, GREASE GUN COUPLING, FLEXIBLE 12 IN. LG, (81349) MILL4387 TYPE 4 CLASS 1, SIZE B		EA	1
2	4930-00-253-2478	GUN, HAND, GREASE (81349) MILG3859 TYPE 1		EA	1
3	4720-00-809-2750	HOSE, ENGINE OIL DRAIN (96906) MS52130-1A20412		EA	1
4	4930-00-274-5713	OILER, HAND (96906) MS15762-1		EA	1
5	TM 3-4230-209-10	Operator's Manual for Decontaminating Apparatus, Power-Driven, Skid-Mounted: 500-Gallon, M12A1		EA	1
6	8465-00-128-6928	PAIL COLLAPSIBLE, NYLON (54212)		EA	1
7	5120-00-321-4507	PLIERS, CAMLOC (71286) 4P3		EA	1

TM 3-4230-209-10

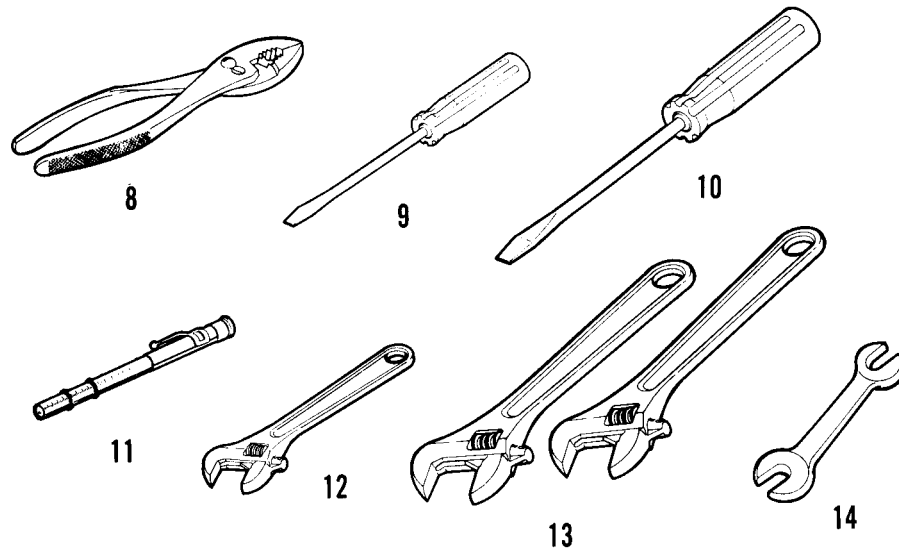

(1) Illus Number	(2) National Stock Number	(3) Description FSCM and Part Number	Usable On Code	(4) U/M	(5) Qty Rqr
8	5120-00-223-7396	PLIERS, SLIP JOINT, STRAIGHT NOSE COMB. 6 IN. TYPE 2, STYLE A, CLASS 2 (81348) GGGP00471		EA	1
9	5120-00-062-0813	SCREWDRIVER, FLAT TIP, 6 IN. (81348) GGGG121		EA	1
10	5120-00-278-1280	SCREWDRIVER, FLAT TIP, 8 IN. (81348) GGGG121		EA	1
11	6635-00-921-6255	TENSIOMETER, V-BELT (24161) 12998F		EA	1
12	5120-00-240-5328	WRENCH, OPEN END, ADJ: 8 IN. (81348) GGGW631		EA	1
13	5120-00-423-6728	WRENCH, OPEN END, ADJ: 15 IN. (96906) MS15461-6		EA	2
14	5120-00-187-7126	WRENCH, OPEN END, FIXED: 9/16 IN. AND 5/8 IN. (81348) GGGW636		EA	1

APPENDIX C ADDITIONAL AUTHORIZATION LIST

Section 1. INTRODUCTION

C-1. SCOPE. This appendix lists additional items authorized for the support of the decontaminating apparatus.

C-2. GENERAL. This list identifies items that do not have to accompany the decontaminating apparatus and that do not have to be turned in with it. These items are all authorized by CTA, MTOE, TDA, or JTA.

C-3. EXPLANATION OF LISTING. National stock numbers, descriptions, and quantities are provided to help you identify and request the additional items required to support this equipment. The items are listed in alphabetical sequence by item name under the type document (i.e., CTA, MTOE, TDA, or JTA) which authorizes the item(s).

Section II. ADDITIONAL AUTHORIZATION LIST

NONE

APPENDIX D EXPENDABLE/DURABLE SUPPLIES AND MATERIALS LIST

Section I. INTRODUCTION

D-1. SCOPE. This appendix lists expendable/durable supplies and materials needed to operate and maintain the decontaminating apparatus. This listing is for informational purposes only and is not authority to requisition the listed items. These items are authorized by CTA 50-970, Expendable/Durable Items (Except Medical, Class V, Repair Parts, and Heraldic Items), or CTA 8-100, Army Medical Department Expendable/Durable Items.

D-2. EXPLANATION OF COLUMNS.

a. *Column (1) - Item Number.* This number is assigned to the entry in the listing and is referenced in the narrative instructions to identify the material (e.g., "Use general purpose detergent, item 8, app D).

b. *Column (2) - Level.* This column identifies the lowest level of maintenance that requires the listed item.

C - Operator/Crew

c. *Column (3) - National Stock Number.* This is the National stock number assigned to the item; use it to request or requisition the item.

d. *Column (4) - Description.* Indicates the Federal item name and, if required, a description to identify the item. The last line for each item indicates the Federal Supply Code for Manufacturer (FSCM) in parentheses followed by the part number.

e. *Column 5- Unit of Measure (U/M).* Indicates the measure used in performing the actual maintenance function. This measure is expressed by a two-character alphabetical abbreviation (e.g., ea, in., pr). If the unit of measure differs from the unit of issue, requisition the lowest unit of issue that will satisfy your requirements.

Section II. EXPENDABLE/DURABLE SUPPLIES AND MATERIALS LIST

(1) ITEM NO.	(2) LEVEL	(3) NATIONAL STOCK NUMBER	(4) DESCRIPTION	(5) U/M
1	C	6850-00-950-6489	ANTIFOAM COMPOUND, SILICONE (71984) ANTIFOAM B 5 gal can	GL
2	C	6850-00-656-0926	ANTISETTING COMPOUND DECONTAMINATING SLURRY (81349) MILA51027 12-1/2 lb drum	LB

TM 3-4230-209-10

(1) Item No.	(2) Level	(3) National Stock Number	(4) Description	(5) U/M
3	C	7920-00-255-7536	BRUSH, CHASSIS AND RUNNING GEAR (81348) H-B-181	EA
4	C	8020-00-205-6511	BRUSH, PAINT, 1 IN. (81348) H-B-491	EA
5	C	7920-00-291-5815	BRUSH, WIRE, SCRATCH TYPE 2, class 1 (81348) H-B-178	EA
6	C	6810-00-255-0472	CALCIUM HYPOCHLORITE TECHNICAL (81438) O-C-114 100 lb drum	LB
7	C	6850-00-297-6653	DECONTAMINATING AGENT STB (81349) MIL-D-12468 50 lb drum	LB
8	C	7930-00-985-6911	DETERGENT, GENERAL PURPOSE liquid form (77902) TRITONX 100 5 gal can	GL
9	C	9140-00-286-5294	DIESEL FUEL grade DF-2 (81348) VUF800GRADED2RE	GL
10	C	6850-00-274-5429	DRY CLEANING SOLVENT liquid form (81348) P-D-680 5 gal can	GL
11	C	8010-00-286-7758	ENAMEL YELLOW NO. 13538 (81349) TT-E-489G 1 qt can	QT
12	C	4210-01-056-8343	FOAM LIQUID, FIRE EXTINGUISHING (81349) MIL-F-24385 5 gal can	GL

(1) ITEM NO.	(2) LEVEL	(3) NATIONAL STOCK NUMBER	(4) DESCRIPTION	(5) U/M
13	C	9140-00-247-4365	FUEL OIL, BURNER grade No. 2 (81348) VVF815	GL
14	C	9130-00-148-7103	GASOLINE, AUTOMOTIVE grade regular mogas unleaded (81348) VVG001690/A	GL
15	C	8415-00-823-7457	GLOVES, CHEMICAL AND OIL PROTECTIVE (81348) ZZ-G-381	PR
16	C	9150-00-190-0905	GREASE, AUTOMOTIVE AND ARTILLERY (81349) BRAYCOTE 610 6.5 lb can	LB
17	C	9140-00-242-6748	KEROSENE (81348) VVK211	GL
18	C	9150-00-186-6681	LUBRICATING OIL: 30 wt (81349) MIL-L-2104	QT
19	C	9150-00-231-2361	LUBRICATING OIL, GENERAL PURPOSE, PL-M (19203) 814370 1 qt can	QT
20	C	9150-00-231-6689	LUBRICATING OIL, GENERAL PURPOSE, PL-S (19204) 14-0-2834-10 1 qt can	QT
21	C	8010-01-160-6741	POLYURETHANE COATING (GREEN 383) (81349) MIL-C-46168B 1 qt kit	QT
22	C	7920-00-205-1711	RAG, WIPING: cotton (58536) AA-A-531 50 lb bale	EA

TM 3-4230-209-10

(1) ITEM NO.	(2) LEVEL	(3) NATIONAL STOCK NUMBER	(4) DESCRIPTION	(5) U/M
23	C	6810-00-264-6618	SODIUM BICARBONATE, TECHNICAL POWDER FORM (81348) O-S-576 1 lb box	LB
24	C	6810-00-233-1715	SODIUM CARBONATE (81348) 05571 100 lb bag	LB
25	C	6810-00-174-6581	SODIUM HYDROXIDE, TECHNICAL flake form (70829) 1308 100 lb drum	LB
26	C	5970-00-419-4290	TAPE, INSULATION, ELECTRICAL black plastic (20999) 7-1/2 INBLACK 108 ft roll	FT
27	C	7510-00-816-8077	TAPE, PRESSURE SENSITIVE (81348) L-T-80 3 in. wide, 6 yd roll	YD
28	C	9130-00-256-8613	TURBINE FUEL, AVIATION (81349) MILT5624 Grade JP-4	GL
29	C	9130-00-256-2379	TURBINE FUEL, AVIATION (81349) MILT5624 Grade JP-5	GL

ALPHABETICAL INDEX

<i>Subject</i>	<i>Page</i>
A	
Additional Authorization List	C-1
Alternator/Generator Assembly	2-43
B	
Basic Issue Items	B-1
Battery	2-24
Blender Hose Assembly	2-46
C	
Cabinet Top Cover	2-49
Centrifugal Pump	2-39
Chemical Protective Clothing	2-57
Cleaning and Storage Procedures after a Spraying Mission	2-125
Clevis and Eyebolt Assemblies	2-22
Clothing, Protective	2-57
Components of End Item	B-1
Connector Panel	2-36
Control Box Assembly	2-51
Control Panel Assembly	2-44
Cover Panels	
Water Heater	2-50
Pump Unit	2-22
D	
Decals and instruction Plates, Operating Instructions	2-126
Description and Use of Operator's Controls and Indicators	2-1
Discharge Hose Assemblies	2-27
Drain Valve, Tank	2-47
Drive Belts	2-37
E	
Eductor Hose Assembly	2-28
Engine and Pump Unit Canvas Protective Cover	2-21
Engine Assembly, 20 HP Gasoline	2-42,3-18
Equipment Characteristics, Capabilities and Features	1-2
Equipment Data	1-8
Expendable/Durable Supplies and Materials	D-1

TM 3-4230-209-10

Subject

Page

F

Fabricated Lines 2-52
Foot Valve Assembly 2-47
Frame Assembly..... 2-37
Fuel Hose Assembly 2-53
Fueling 2-57
Fuel Pump 2-55
Fuel Pump and Ignition Drive Motor 2-54
Fuel Tank 2-29

G

Gasoline Engine Assembly, 20 HP 2-42, 3-18
General Cleaning Instructions 3-1
Gun Assembly 3-14

H

Heating Water 2-79
Heating Water Drawn from a Natural Source 2-87
Heating Water from the Tank 2-89
Heating Water in the Tank 2-124.1
Hopper Assembly 2-46
Hose Assemblies 2-46, 2-53
Hose Reels 2-35
How to Use This Manual iii

I

Initial Adjustments, Daily Checks and Self Tests 2-59

L

Liquid Fuel Water Heater 2-48
Loading Supplies and Protective Clothing 2-59
Loading Tank from a Natural Source 2-76
Loading Tank from a Pressure Source 2-76
Location and Description of Major Components 1-2
Low Pressure Heating Boiler Assembly 2-56
Lubrication Instructions 3-1

PIN: 060191-002

☆U.S. GOVERNMENT PRINTING OFFICE: 1997 - 545-039/40081

Change 2 Index 2

<i>Subject</i>	<i>Page</i>
M	
Magneto Assembly	2-54
Maintenance Forms and Records	1-1
Making STB Decontaminating Agent Slurry	2-91
Mixing Chemicals Other Than STB in Tank	2-100
Mixing Water and Liquid Chemicals Using the Prime-Detergent Tank	2-114
O	
Operating Instructions on Decals and instruction Plates	2-126
Operation under Unusual Conditions	2-134
Operation under Usual Conditions	2-57
Operator's Preventive Maintenance Checks and Services (PMCS)	2-16
P	
Personnel	2-57
Personnel Shower Assembly	2-19, 3-14
Plumbing Assembly	2-38
Power Cable	2-53
Preparation for Operation	2-59
Preventive Maintenance Checks and Services (PMCS)	2-16
Prime-Detergent Tank Assembly and Tank Lid	2-26
Pump Unit Canvas Protective Cover	2-21
Pump Unit Checklist	2-62
Pump Unit Frame	
Inspection	2-37
Service	2-37
Pump Unit Subassembly	2-34
R	
References	A-1
Reporting Equipment improvement Recommendations (EIR)	1-1
S	
Showering	2-118
Skid Assembly	2-53
Skid Base Subassembly	2-37
Slurry Nozzle Assembly	2-25
Spraying Water from a Natural Source	2-71
Spraying Water from Tank	2-74
Starting the Pump Unit	2-60
Stopping the Pump Unit	2-68
Suction Hose Assembly	2-46

TM 3-4230-209-10

Subject *Page*

T

Tank Drain Valve	2-47
Tank Unit	2-45
Troubleshooting Procedures	
Additives Fail to mix in Solution..	3-13
Burner Sputters Out	3-9
Engine Fails to Start	3-4
Pump Inoperative	3-6
Pump Over heats or IsNoisy	3-8
Pump Pressure Low or Falling	3-5
Pump Vibrates Excessively	3-8
Water Not Hot Enough	3-12
Water Too Hot	3-11

V

VALVE NO.2 LOWER REEL and VALVE NO. 3 UPPER REEL..	2-41
VALVE NO.1 MANIFOLD	2-40

W

Water Heater, Liquid Fuel	2-48
Water Hose Assembly	2-53

RECOMMENDED CHANGES TO EQUIPMENT TECHNICAL PUBLICATIONS



THEN...JOT DOWN THE DOPE ABOUT IT ON THIS FORM. CAREFULLY TEAR IT OUT, FOLD IT AND DROP IT IN THE MAIL!

SOMETHING WRONG WITH THIS PUBLICATION?

FROM: (PRINT YOUR UNIT'S COMPLETE ADDRESS)

DATE SENT

PUBLICATION NUMBER

TM 3-4230-209-10

PUBLICATION DATE

PUBLICATION TITLE

Decontaminating Apparatus,
Power-Driven, Skid-Mounted: 500-Gallon, M12A1

BE EXACT...PIN-POINT WHERE IT IS

PAGE NO.	PARA-GRAPH	FIGURE NO.	TABLE NO.
----------	------------	------------	-----------

1-3	1-6		
3-1	3-3		
3-18	3-10		

IN THIS SPACE TELL WHAT IS WRONG AND WHAT SHOULD BE DONE ABOUT IT:

Tank unit illustration shows suction hose item #3 as two hoses coupled together. Reason: Suction hose is now one hose. Text refers to cleaning solvent item 7, App.D in Expendable Supplies Section. Reason: Should be item 10, App.D. Blender hose illustration is not accurate as shown. Reason: Blender hose should show quick disconnect couplings at both ends.

SAMPLE

PRINTED NAME, GRADE OR TITLE, AND TELEPHONE NUMBER

SSG. TED RYBA 671-3681

SIGN HERE

SSG Ted Ryba

DA FORM 2028-2
1 JUL 79

PREVIOUS EDITIONS ARE OBSOLETE.

P.S. --IF YOUR OUTFIT WANTS TO KNOW ABOUT YOUR RECOMMENDATION MAKE A CARBON COPY OF THIS AND GIVE IT TO YOUR HEADQUARTERS.

TEAR ALONG DOTTED LINE

RECOMMENDED CHANGES TO EQUIPMENT TECHNICAL PUBLICATIONS



SOMETHING WRONG WITH THIS PUBLICATION?

*THEN...JOT DOWN THE
DOPE ABOUT IT ON THIS
FORM, CAREFULLY TEAR
IT OUT, FOLD IT AND DROP
IT IN THE MAIL!*

FROM: (PRINT YOUR UNIT'S COMPLETE ADDRESS)

DATE SENT

PUBLICATION NUMBER: **TM 3-4230-209-10** PUBLICATION DATE: _____ PUBLICATION TITLE: Decontaminating Apparatus, Power-Driven, Skid-Mounted: 500-Gallon, M12A1

BE EXACT...PIN-POINT WHERE IT IS **IN THIS SPACE TELL WHAT IS WRONG AND WHAT SHOULD BE DONE ABOUT IT:**

PAGE NO.	PARA-GRAPH	FIGURE NO.	TABLE NO.	

PRINTED NAME, GRADE OR TITLE, AND TELEPHONE NUMBER

SIGN HERE:

TEAR ALONG DOTTED LINE

FILL IN YOUR
UNIT'S ADDRESS

FOLD BACK

DEPARTMENT OF THE ARMY

OFFICIAL BUSINESS
PENALTY FOR PRIVATE USE, \$300

POSTAGE AND FEES PAID
DEPARTMENT OF THE ARMY
DOD-314



TEAR ALONG DOTTED LINE

Commander
US Army Armament, Munitions and Chemical Command
ATTN: AMSMC-MAR-T (A)
Aberdeen Proving Ground, MD 21010-5423

RECOMMENDED CHANGES TO EQUIPMENT TECHNICAL PUBLICATIONS



SOMETHING WRONG WITH THIS PUBLICATION?

THEN...JOT DOWN THE DOPE ABOUT IT ON THIS FORM, CAREFULLY TEAR IT OUT, FOLD IT AND DROP IT IN THE MAIL!

FROM: (PRINT YOUR UNIT'S COMPLETE ADDRESS)

DATE SENT

PUBLICATION NUMBER
TM 3-4230-209-10

PUBLICATION DATE

PUBLICATION TITLE
Decontaminating Apparatus,
Power-Driven, Skid-Mounted: 500-Gallon, M12A1

BE EXACT...PIN-POINT WHERE IT IS				IN THIS SPACE TELL WHAT IS WRONG AND WHAT SHOULD BE DONE ABOUT IT:
PAGE NO.	PARA-GRAPH	FIGURE NO.	TABLE NO.	

PRINTED NAME, GRADE OR TITLE, AND TELEPHONE NUMBER

SIGN HERE:

TEAR ALONG DOTTED LINE

REVERSE OF DA FORM 2028-2

FILL IN YOUR
UNIT'S ADDRESS

FOLD BACK

DEPARTMENT OF THE ARMY

OFFICIAL BUSINESS
PENALTY FOR PRIVATE USE, \$300

POSTAGE AND FEES PAID
DEPARTMENT OF THE ARMY
DOD-314



TEAR ALONG DOTTED LINE

Commander
US Army Armament, Munitions and Chemical Command
ATTN: AMSMC-MAR-T (A)
Aberdeen Proving Ground, MD 21010-5423

RECOMMENDED CHANGES TO EQUIPMENT TECHNICAL PUBLICATIONS



SOMETHING WRONG WITH THIS PUBLICATION?

THEN...JOT DOWN THE DOPE ABOUT IT ON THIS FORM, CAREFULLY TEAR IT OUT, FOLD IT AND DROP IT IN THE MAIL!

FROM: (PRINT YOUR UNIT'S COMPLETE ADDRESS)

DATE SENT

PUBLICATION NUMBER
TM 3-4230-209-10

PUBLICATION DATE

PUBLICATION TITLE
Decontaminating Apparatus,
Power-Driven, Skid-Mounted: 500-Gallon, M12A1

BE EXACT...PIN-POINT WHERE IT IS				IN THIS SPACE TELL WHAT IS WRONG AND WHAT SHOULD BE DONE ABOUT IT:
PAGE NO.	PARA-GRAPH	FIGURE NO.	TABLE NO.	

PRINTED NAME, GRADE OR TITLE, AND TELEPHONE NUMBER

SIGN HERE.

TEAR ALONG DOTTED LINE

DA FORM 1 JUL 79 2028-2

PREVIOUS EDITIONS ARE OBSOLETE.

P.S. --IF YOUR OUTFIT WANTS TO KNOW ABOUT YOUR RECOMMENDATION MAKE A CARBON COPY OF THIS AND GIVE IT TO YOUR HEADQUARTERS.

FILL IN YOUR
UNIT'S ADDRESS

FOLD BACK

DEPARTMENT OF THE ARMY

OFFICIAL BUSINESS
PENALTY FOR PRIVATE USE, \$300

POSTAGE AND FEES PAID
DEPARTMENT OF THE ARMY
DOD-314



TEAR ALONG DOTTED LINE

Commander
US Army Armament, Munitions and Chemical Command
ATTN: AMSMC-MAR-T (A)
Aberdeen Proving Ground, MD 21010-5423

By Order of the Secretary of the Army:

JOHN A. WICKHAM, JR.
General, United States Army
Chief of Staff

Official:

R. L. DILWORTH
Brigadier General, United States Army
The Adjutant General

Distribution:

To be distributed in accordance with DA Form 12-28R, Quantity Required Block 169, Operator's Requirement for Decontaminating Apparatus, Skid-Mounted: Multi purpose Nonintegral 500-Gallon, M12A1 (NSN 4230-00-926-9488).

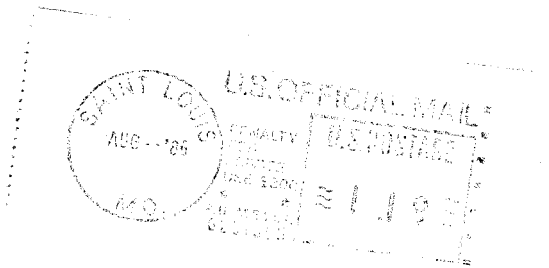

DEPARTMENT OF THE ARMY
 US ARMY PUBLICATIONS CENTER
 1655 WOODSON ROAD
 ST. LOUIS, MISSOURI 63114-6181

OFFICIAL BUSINESS
 PENALTY FOR PRIVATE USE, \$300

SPECIAL FOURTH
 CLASS BOOK RATE

COMMANDER
 USAMC MAT RENS SPT ACTV
 ATTN AMXMD-PO(LIBRARY)
 LEXINGTON

MC455

KY 40511

DA PUBLICATION/FORM NUMBER				CHG OR DATE	
TM 3-4230-209-10					
LOCATION	QUANTITY	UNIT OF ISSUE	ACTION	RON DATE	
B-1	2	INITIAL-DIST.			
PKG SIZE	ITEM NO.	BULK/Rcpt DATE	SLAGPC CONTROL NO.		
1296			ID-6226-C4EE3		

TAGO FORM 4-26a, 1 SEP 78

PREVIOUS EDITION OF THIS FORM IS OBSOLETE